



COLLETON COUNTY
SOUTH CAROLINA
Purchasing Department
113 Mable T. Willis Blvd.
Walterboro, SC 29488
843.782.0504

BID: CC-38
HARRELSON BUILDING
TECHNOLOGY DEPT. IMPROVEMENTS PROJECT

Due: Wednesday, April 19, 2023 at 11:00am

EMAIL RESPONSE TO:

Kaye B. Syfrett, Procurement Manager at ksyfrett@colletoncounty.org

No mandatory Pre-bid Meeting. Contractors and Subcontractors are encouraged to inspect the site on **Thursday, March 16, 2023 at 10:00am**. This will be the only available time for entry into the Technology Department.

All questions are to be submitted via email to; **jstieglitz@colletoncounty.org no later than 11:00am on Thursday, March 30, 2023.**

TABLE OF CONTENTS
(1 OF 2)

BIDDING AND CONTRACT REQUIREMENTS

| | |
|-------------------------------------|-----------|
| Advertisement for Bid..... | 3 |
| Information for Bidders..... | 3 |
| Contract..... | 20 |
| Reference Forms..... | 26 |
| Bid Forms..... | 53 |

END OF SECTION

ADVERTISEMENT FOR BID

Owner: Colleton County, 109 Benson Street, Walterboro, South Carolina

Bid: CC-38 Harrelson Building - Technology Dept. Improvements project will be submitted **via email to: Kaye B. Syfrett, Procurement Manager at ksyfrett@colletoncounty.org until 11:00am, Wednesday, April 19, 2023.** The work to be completed as a part of this project consists of providing all required material, equipment and labor necessary to complete the renovation and construction of the technology department located at 31 Klein Street, Walterboro, SC, with the following approximate quantities:

Renovation of the current Technology Dept. workspace in the Harrelson Building at 31 Klein Street, Walterboro, SC 29488. The project includes a new network workspace, office space renovation, technology support systems, applicable equipment, and 1st-floor corridor improvements.

The Instructions to Bidders, bid packet, Contract, Plans, Specifications, and other contract documents may be examined at the following location:

Colleton County website: <https://www.colletoncounty.org/bids-proposal-requests>

Bidders must deposit security with all bids. Security shall be in the form of a certified check or bid bond made payable to Colleton County, and shall be for an amount equal to not less than five percent (5%) of the amount of the bid. Provisions of the security shall be as described in the Information for Bidders. No bid will be considered unless the bidder is legally qualified under the provisions of the South Carolina Sections 40-11-10 through 40-11-428.

NOTICE TO BIDDERS:

Each bidder shall fully acquaint him/herself with conditions of this Bid. The failure or omission of a bidder to acquaint him/herself with the plans, specifications and existing conditions shall in no way relieve him/herself of any obligation with respect to this Bid or to the Contract.

BIDS WILL NOT BE CONSIDERED FROM ANY VENDOR THAT OWES DELINQUENT PROPERTY TAXES TO THE COUNTY OF COLLETON.

All questions about the meaning or intent of the Bidding Documents are to be submitted in writing via email to; jstieglitz@colletoncounty.org no later than 11:00am on Thursday, March 30, 2023.

NOTICE TO BIDDERS: All amendments to and interpretations of this solicitation shall be in writing and issued by the Colleton County Procurement Manager. Colleton County shall not be legally bound by any amendment or interpretation that is not in writing. Award of the project is contingent on funding approval by Colleton County Council.

The Owner reserves the right to waive any informality or to reject any or all bids.

Architect

**Glick Boehm Architecture
493 King Street
Charleston, SC 29403
Shawn Mellin, AIA, LEED AP
Information for Bidders**

Owner

**Colleton County
109 Benson Street
Walterboro, SC 29488**

ARTICLE 1 - DEFINED TERMS

- 1.01 Terms used in these Instructions to Bidders have the meanings indicated in the 001, General Conditions. Additional terms used in these Instructions to Bidders have the meanings indicated below:
- A. **Issuing Office** - The office from which the Bidding Documents are to be issued and where the bidding procedures are to be administered.
 - B. **Architect, Engineer, Owner** - The person or firm in charge of the design of the project. In some instances, the owner will self-perform, acting as the Architect.
 - C. **Construction Coordinator** - The person or company acting on behalf of the owner and in some instances, the owner will self-perform, acting as the Construction Coordinator.
 - D. **Owner** - Colleton County
 - E. **Official Time** - The time as noted on the Atomic Clock located in the Purchasing office lobby. All times are Eastern Standard Time.
 - F. **Substantial Completion** - The point of construction whereas the owner can fully occupy the facility, perform all aspects of the intended use of the facility and not be inhibited with final punch list items. Certificate of occupancy does not constitute substantial completion. The owner must agree that the project is substantially complete.

ARTICLE 2 - COPIES OF BIDDING DOCUMENTS

- 2.01 Complete sets of the Bidding Documents can be found on Colleton County's website at: <https://www.colletoncounty.org/bids-proposal-requests>
- 2.02 Complete sets of Bidding Documents shall be used in preparing Bids; neither the Owner nor Engineer or Architect assumes any responsibility for errors or misinterpretations resulting from the use of incomplete sets of Bidding Documents.
- 2.03 The Owner, Engineer or Architect, in making copies of Bidding Documents available on the above terms, do so only for the purpose of obtaining Bids for the Work and do not confer a license or grant for any other use.

ARTICLE 3 - QUALIFICATIONS OF BIDDERS AND SPECIAL CONDITIONS

- 3.01 Bidders must be licensed as a General Contractor in the State of South Carolina and will hold all Trade Contracts and the Building Permits on the project.
- 3.02 To demonstrate Bidder's qualifications to perform the Work, within five (5) days of the Owner's request, Bidder shall submit written evidence such as financial data; previous experience, present commitments.
- 3.03 **As this project will have unique circumstances and needs concerning the installation and future maintenance requirements, Colleton County has determined it is in the best interest that any Electrical Subcontractor working on this project shall be a local resident of Colleton County. Therefore, no other Electrical Subcontractors may be used.**
- 3.04 Davis-Bacon Prevailing Wage does not apply to this project.

ARTICLE 4 - EXAMINATION OF BIDDING DOCUMENTS, OTHER RELATED DATA, AND SITE

- 4.00 No mandatory Pre-bid Meeting. Contractors and Subcontractors are encouraged to inspect the site on **Thursday, March 16, 2023 at 10:00am**. This will be the only available time for entry into the Technology Department.
- 4.01 Subsurface and Physical Conditions
- A. The General Conditions identify:
- No reports of explorations and tests of conditions at or contiguous to the Site were performed.
- 4.02 Underground Facilities
- A. Information and data shown or indicated in the Bidding Documents with respect to existing Underground Facilities at or contiguous to the Site is based upon information and data furnished to the Owner and Engineer or Architect by the owners of such Underground Facilities, including the Owner, or others.
- 4.03 Hazardous Environmental Condition
- A. The General Conditions identify those reports and drawings relating to a Hazardous Environmental Condition identified at the Site, if any, that Engineer or Architect has used in preparing the Bidding Documents.
- B. Copies of any reports and drawings referenced in Paragraph 4.03.A are included herein. Those reports and drawings are not part of the Contract Documents, but the “technical data” contained therein upon which Bidder is entitled to rely as provided in Paragraph 4.06 of the General Conditions has been identified and established. Bidder is responsible for any interpretation or conclusion Bidder draws from any “technical data” or any other data, interpretations, opinions, or information contained in such reports or shown or indicated in such drawings.
- 4.04 Provisions concerning responsibilities for the adequacy of data furnished to prospective Bidders with respect to subsurface conditions, other physical conditions and Underground Facilities, and possible changes in the Bidding Documents due to differing or unanticipated conditions appear in Paragraphs 4.02, 4.03, and 4.04 of the General Conditions. Provisions concerning responsibilities for the adequacy of data furnished to prospective Bidders with respect to a Hazardous Environmental Condition at the Site, if any, and possible changes in the Contract Documents due to any Hazardous Environmental Condition uncovered or revealed at the Site which was not shown or indicated in the Drawings or Specifications or identified in the Contract Documents to be within the scope of the Work appear in Paragraph 4.06 of the General Conditions.
- 4.05 Reference is made to Article 7 of the General Conditions for the identification of the general nature of other work that is to be performed at the Site by the Owner or others (such as utilities and other prime contractors) that relates to the Work contemplated by these Bidding Documents. On request, the Owner will provide to each Bidder for examination access to or copies of Contract Documents (other than portions thereof related to price) for such other work.

- 4.06 It is the responsibility of each Bidder before submitting a Bid to:
- a. Examine and carefully study the Bidding Documents, the other related data identified in the Bidding Documents, and any Addenda.
 - b. Visit the Site and become familiar with and satisfy Bidder as to the general, local, and Site conditions that may affect cost, progress, and performance of the Work.
 - c. Become familiar with and satisfy Bidder as to all federal, state, and local Laws and Regulations that may affect cost, progress, and performance of the Work.
 - d. Carefully study all: (1) all drawings of physical conditions in or relating to existing surface or subsurface structures (except Underground Facilities), which have been identified.
 - e. Obtain and carefully study (or accept consequences of not doing so) all additional or supplementary examinations, investigations, explorations, tests, studies, and data concerning conditions (surface, subsurface, and Underground Facilities) at or contiguous to the Site, which may affect cost, progress, or performance of the Work or which relate to any aspect of the means, methods, techniques, sequences, and procedures of construction to be employed by Bidder, including applying any specific means, methods, techniques, sequences, and procedures of construction expressly required by the Bidding Documents, and safety precautions and programs incident thereto.
 - f. Agree at the time of submitting its Bid that no further examinations, investigations, explorations, tests, studies, or data are necessary for the determination of its Bid for performance of the Work at the price(s) bid and within the times and in accordance with the other terms and conditions of the Bidding Documents.
 - g. Become aware of the general nature of the work to be performed by the Owner and others at the Site that relates to the Work as indicated in the Bidding Documents.
 - h. Correlate the information known to Bidder, information and observations obtained from visits to the Site, reports and drawings identified in the Bidding Documents, and all additional examinations, investigations, explorations, tests, studies, and data with the Bidding Documents.
 - i. Promptly give the Owner written notice of all conflicts, errors, ambiguities, or discrepancies that Bidder discovers in the Bidding Documents and confirm that the written resolution thereof by the Owner is acceptable to Bidder.
 - j. Determine that the Bidding Documents are generally sufficient to indicate and convey understanding of all terms and conditions for the performance of the Work.
 - k. No plea of ignorance of conditions that exist or may hereafter exist on the site of the work, or difficulties that may be encountered in the execution of the work, as a result of failure to make necessary investigations and examinations, will be accepted as an excuse for any failure or omission on the part of the Contractor to fulfill in every detail all the requirements of the contract documents and to complete the work for the consideration set forth therein, or as basis for any claim whatsoever.

- l. Apparent omission of a detailed description concerning any point, shall be regarded as meaning the best commercial practice is to prevail and that only material and workmanship of the finest quality is to be used.
 - m. Bidders may refer to Sections 2-67, 2-73, and 2-74 of Ordinance #2008-09, also known as the Colleton County, South Carolina Purchasing Policy to determine their remedies concerning this competitive process. The failure to be awarded a bid shall not be valid grounds for protest.
 - n. The Bidder further agrees that the performance time specified is a reasonable time, having carefully considered the nature and scope of the project as aforesaid.
- 4.07 The submission of a Bid will constitute an incontrovertible representation by Bidder that Bidder has complied with every requirement of this Article 4, that without exception the Bid is premised upon performing and furnishing the Work required by the Bidding Documents and applying any specific means, methods, techniques, sequences, and procedures of construction that may be shown or indicated or expressly required by the Bidding Documents, that Bidder has given the Owner written notice of all conflicts, errors, ambiguities, and discrepancies that Bidder has discovered in the Bidding Documents and the written resolutions thereof by the Owner are acceptable to Bidder, and that the Bidding Documents are generally sufficient to indicate and convey understanding of all terms and conditions for performing and furnishing the Work.

ARTICLE 5 - SITE AND OTHER AREAS

- 5.01 The Site is identified in the Bidding Documents. Easements for permanent structures or permanent changes in existing facilities are to be obtained and paid for by the Owner unless otherwise provided in the Bidding Documents. All additional land and access thereto required for temporary construction facilities, construction equipment, or storage of materials and equipment to be incorporated in the Work are to be obtained and paid for by Contractor.

ARTICLE 6 - INTERPRETATIONS AND ADDENDA

- 6.01 All questions about the meaning or intent of the Bidding Documents are to be submitted via email to; jstieglitz@colletoncounty.org **no later than 11:00am on Thursday, March 30, 2023** Questions received after this date and time will not be answered. Interpretations or clarifications considered necessary by the Owner in response to such questions will be issued by Addenda. Only questions answered by Addenda will be binding. Oral and other interpretations or clarifications will be without legal effect.
- 6.02 Addenda may be issued to clarify, correct, or change the Bidding Documents as deemed advisable by the Owner. Addenda will be posted on the Colleton County website. It is the responsibility of the bidder to monitor this website for addendums.
- 6.03 Division 000 and Division 001 shall have authority over all other documents contained within the project manual. Where duplication of titles, articles, standards, requirements and such are found, division 000 and Division 001 govern.

ARTICLE 7 - BID SECURITY

- 7.01 A Bid must be accompanied by Bid security made payable to Colleton County in an amount of five percent (5%) of Bidder's maximum Bid price and in the form of a certified check, bank money order, or a Bid Bond (on the form attached) issued by a surety meeting the requirements of Paragraphs 5.01 and 5.02 of the General Conditions.
- 7.02 The Bid security of the Successful Bidder will be retained until such Bidder has executed the Contract Documents, furnished the required contract security and met the other conditions of the Notice of Award. If the Successful Bidder fails to execute and deliver the Contract Documents and furnish the required contract security within ten (10) days after the Notice of Award, the Owner may annul the Notice of Award and the Bid security of that Bidder will be forfeited. The Bid security of other Bidders whom the Owner believes to have a reasonable chance of receiving the award may be retained by the Owner until the earlier of seven (7) days after the Effective Date of the Agreement or sixty (60) days after the Bid opening. Bidders not receiving a contract for will be issued a copy of the Notice of Award to send to their issuing Surety so that the Bid Bond can be canceled. Bidders Bid Bond documents will not be returned. All Certified Checks will be returned to the Bidders.

ARTICLE 8 - CONTRACT TIMES

- 8.01 **Renovation of the current Technology Dept. workspace in the Harrelson Building at 31 Klein Street, Walterboro, SC 29488. The project includes a new network workspace, office space renovation, technology support systems, applicable equipment, and 1st-floor corridor improvements to be completed within Two Hundred Seventy (270) calendar days after the "Notice to Proceed" has been issued.**

ARTICLE 9 – LIQUIDATED DAMAGES

- 9.01 Document Execution
- A. The successful Bidder, upon failure or refusal to execute and deliver the contract and bonds within ten (10) days after they have received the notice of the acceptance of their bid, shall forfeit to the Owner, as liquidated damages, the security deposited with the bid.
- 9.02 Project Execution
- A. Bidder must agree to commence work on or before a date to be specified in a written "Notice to Proceed" by the Owner and to fully complete the project within the dates specified in the Bid Form, Article 6; Paragraph 6.01. Bidder must agree also to pay as liquidated damages the sum as indicated in the Bid Form, Article 6; Paragraph 6.02 for each consecutive calendar day thereafter as hereinafter provided in the General Conditions.

ARTICLE 10 - SUBSTITUTE AND "OR-EQUAL" ITEMS

- 10.01 The Contract, if awarded, will be on the basis of materials and equipment specified or described in the Bidding Documents. Whenever it is specified or described in the Bidding Documents that a substitute or "or-equal" item of material or equipment may be furnished or used by Contractor if

acceptable to the Construction Coordinator, application for such acceptance will not be considered by the Owner until after the Effective Date of the Agreement.

- (a) The use of a **“Brand Name Only”** specification is for the purpose of describing the sole item that will satisfy the county’s requirements. Bids offering alternate products will be declared non-responsive.
- (b) The use of a **“Brand Name or Equal”** specification is for the purpose of describing the standard of quality, performance and characteristics desired and is not intended to limit or restrict competition. An item shall be considered to be substantially equivalent, or “equal” to the specified brand in the opinion of the Purchasing Director, the County can reasonably anticipate sufficiently similar quality, capacity, durability, performance, utility and productivity as provided by the specified brand.

ARTICLE 11 - SUBCONTRACTORS, SUPPLIERS, AND OTHERS

- 11.01 The General Conditions require the identity of certain Subcontractors, Suppliers, individuals, or entities to be submitted to the Owner with the bid packet. The bidder shall submit to the Owner a list of all such Subcontractors, Suppliers, individuals, or entities proposed for those portions of the Work for which such identification is required. Such list shall be accompanied by an experience statement with pertinent information regarding similar projects and other evidence of qualification for each such Subcontractor, Supplier, individual, or entity if requested by the Owner. If the Owner or Construction Coordinator, after due investigation, has reasonable objection to any proposed Subcontractor, Supplier, individual, or entity, the Owner may, before the Notice of Award is given, request apparent Successful Bidder to submit a substitute, in which case apparent Successful Bidder shall submit an acceptable substitute, Bidder’s Bid price will be increased (or decreased) by the difference in cost occasioned by such substitution, and the Owner may consider such price adjustment in evaluating Bids and making the Contract award.
- 11.02 If apparent Successful Bidder declines to make any such substitution, the Owner may award the Contract to the next lowest Bidder that proposes to use acceptable Subcontractors, Suppliers, individuals, or entities. Declining to make requested substitutions will not constitute grounds for forfeiture of the Bid security of any Bidder. Any Subcontractor, Supplier, individual, or entity so listed and against which the Owner or Construction Coordinator makes no written objection prior to the giving of the Notice of Award will be deemed acceptable to the Owner and Construction Coordinator subject to revocation of such acceptance after the Effective Date of the Agreement as provided in Paragraph 6.06 of the General Conditions.
- 11.03 Contractor shall not be required to employ any Subcontractor, Supplier, individual, or entity against whom Contractor has reasonable objection.
- 11.04 Each bidder shall fully acquaint himself with conditions of this Bid. The failure or omission of a bidder to acquaint himself with existing conditions shall in no way relieve him of any obligation with respect to this Bid or to the Contract.
- 11.05 Failure of a sub-contractor to fully acquaint himself with the conditions of this bid when working on behalf of the General Contractor or contract holder shall in no way relieve himself of any obligation with respect to this Bid or to the Contract.

ARTICLE 12 - PREPARATION OF BID

- 12.01 Should a bidder need any reasonable accommodations for any type of disability in order to participate in this procurement, you are asked to contact the Colleton County Purchasing office.
- 12.02 The Bid Form is included with the Bidding Documents located on the Owners Web Site.
- 12.03 All blanks on the Bid Form shall be completed by printing in ink or by typewriter and the Bid signed in ink. Erasures or alterations shall be initialed in ink by the person signing the Bid Form. When required a Bid price shall be indicated for each unit price item listed therein, or the words "No Bid," "No Charge," or "Not Applicable" entered. When a unit price is not required, the bid price shall be submitted in words and numbers as indicated on the bid form.
- 12.04 A Bid by an individual shall show the Bidder's name and official address.
- 12.05 A Bid by a joint venture shall be executed by each joint venture in the manner indicated on the Bid Form. The official address of the joint venture shall be shown below the signature.
- 12.06 All names shall be typed or printed in ink below the signatures.
- 12.07 The Bid shall contain an acknowledgment of receipt of all Addenda, the numbers of which shall be filled in on the Bid Form.
- 12.08 The address and telephone number for communications regarding the Bid shall be shown.
- 12.09 The Bid shall contain evidence of Bidder's authority and qualification to do business in the state where the Project is located or covenant to obtain such qualification prior to award of the Contract. Bidder's state contractor license number, if any, shall also be shown on the Bid Form.
- 12.10 Any reports, studies, photographs, negatives or other documents prepared by vendor in the performance of its obligations shall be the exclusive property of the procurer and all such material shall be remitted to the procurer by the vendor upon completion, termination or cancellation of this order. Vendor shall not use, willingly allow or cause to have such material used for any purpose other than performance of its obligations under this order without the prior written consent of the procurer.
- 12.11 The contractor will take affirmative action in complying with all Federal and State requirements concerning fair employment and employment of the handicapped, and concerning the treatment of all employees, without regard or discrimination by reason of age, race, color, religion, sex, national origin or physical handicap. The following are incorporated herein by reference: 41 C.F.R. 60-1.4, 60-250.4 and 60-741.4.
- 12.12 All construction contracts over \$2,000.00 must include a provision for compliance with the Copeland "Anti-Kickback" Act (18 U.S.C. 874) as supplemented in Department of Labor regulations (29 CFR Part 3). This act provides that each Contractor shall be prohibited from inducing, by any means, persons employed in the construction, completion, or repaid of public work to give up any part of their compensation.

- 12.13 The contractor certifies that the vendor(s) will provide a “drug-free workplace” as that term is defined in Section 44-107-30 of the Code of Laws of South Carolina, 1976, as amended, by the complying with the requirements set forth in title 44, Chapter 107.
- 12.14 The federally-assisted construction contractor certifies that he will not maintain or provide, for his employees, segregated facilities at any of his establishments and that he will not permit his employees to perform their services at any location under his control where segregated facilities are maintained. The federally assisted construction contractor agrees that a breach of this certification is a violation of the Equal Opportunity Clause in this Contract. As used in this certification, the term "segregated facilities" means any waiting rooms, work areas, restrooms, and washrooms, restaurants and other eating areas, time clocks, locker rooms and other storage or dressing areas, parking lots, drinking fountains, recreation or entertainment areas, transportation, and housing facilities provided for employees which are segregated on the basis of race, color, religion, or national origin because of habit, local custom, or any other reason. The federally assisted construction contractor agrees that (except where he has obtained identical certifications from proposed subcontractors for specific time periods) he will obtain identical certifications from proposed subcontractors prior to the award of subcontracts exceeding \$10,000 which are not exempt from the provisions of the Equal Opportunity Clause and that he will retain such certifications in his files.
- 12.15 By signing this bid or proposal, Contractor certifies that it will (a) comply with the applicable requirements of Title 8, Chapter 14, and (b) include in their contracts with the sub-subcontractor’s language requiring the sub-subcontractors to comply with the applicable requirements of Title 8, Chapter 14. (An overview is available at www.procurement.sc.gov)
- 12.16 Bidders must clearly mark as "confidential" each part of their bid which they consider to be proprietary information that could be exempt from disclosure under section 30-4-40, Code of Laws of South Carolina 1976, as amended (Freedom of Information Act). If any part is designated as confidential, there must be attached to that part an explanation of how this information fits within one or more categories listed in section 30-4-40. The County reserves the right to determine whether this information should be exempt from disclosure and no legal action may be brought against the County or its agents for its determination in this regard.
- 12.17 Nothing herein is intended to exclude any responsible vendor, his product or service or in any way restrain or restrict competition. On the contrary, all responsible vendors are encouraged to bid and their bids are solicited.
- 12.18 The successful Bidder must be responsible for obtaining all necessary city, county, and state permits/licenses and must comply with all State and local codes and ordinances. Copies of such permits/licenses shall be made available to Colleton County upon request. Work within the Walterboro City Limits may require a City Business License.
- 12.19 This Agreement shall be governed by and construed in accordance with the laws of the State of South Carolina, U.S.A.
- 12.20 All claims, disputes and other matters in question between parties arising out of, or relating to, this Agreement, or the breach thereof, shall be decided in the Circuit Court of the Fourteenth Judicial Circuit in Colleton County, South Carolina. By executing this Agreement, all parties specifically consent to venue and jurisdiction in Colleton County, South Carolina and waive any right to contest jurisdiction and venue in said Court.

- 12.21 Colleton County reserves the right to reject all or any part of any bid, waive informalities and award the contract to the lowest responsive and responsible bidder to best serve the interest of Colleton County.
- 12.22 By submitting a bid, the Bidder certifies to the best of its knowledge and belief, that it and its principals, sub-contractors and assigns are not presently debarred, suspended, proposed for debarment, declared ineligible, or voluntarily excluded from covered transactions by any Federal, State or local department or agency. A copy of the County's debarment procedure in accordance with Section 2-68 of Ordinance #2008-09, also known as the Colleton County, South Carolina Purchasing Policy is available upon request.
- 12.23 Federal guidelines require grant recipients to obtain sufficient assurance that bidders are not suspended or debarred from participating in federal programs when contracts exceed \$25,000. By signing the bid submittal form you verify that no party to this agreement is excluded from receiving Federal contracts, certain subcontracts, and certain Federal financial and nonfinancial assistance and benefits, pursuant to the provisions of 31 U.S.C. 6101, note, E.O. 12549, E.O. 12689, 48 CFR 9.404, and each agency's codification of the Common Rule for Non-procurement suspension and debarment. [See <https://www.epls.gov/> for additional information.]

ARTICLE 13 - BASIS OF BID; COMPARISON OF BIDS

13.01 Base Bid and Unit Price Schedule

- A. Bidders shall submit a base bid for the project, as listed in the Specifications, General Conditions, Drawings and any Addendums. Failure for the Contractor or Subcontractor(s) to properly perform takeoffs for the project does not relieve the bidder of their obligation to provide a complete, finished product, for the submitted base bid amount. **The base bid shall include any owner listed Allowances or contingencies that are in the plans, specifications or bid packet.**
- B. Bidders shall submit a Base Bid as a lump sum.
- C. Within 48 hours of the apparent lowest responsive bidder being notified by Colleton County, the bidder shall submit to Colleton County for **review and approval**, the attached unit price schedule for each item of work listed. All quantity take offs shall be listed in the form as requested. All requested unit pricing shall have a figure entered into the form. Lumping of unit prices and or divisions will not be allowed. Unit prices shall be totaled to match the lump sum bid. Failure for the bidder to provide this information in the allotted time will result in the bidder being disqualified and shall forfeit their Bid Bond.
- D. The total of all unit prices will be the sum of the products of the quantity of each item and the corresponding unit price.
- E. Discrepancies between the indicated sum of any column of figures and the correct sum thereof will be resolved in favor of the correct sum. Discrepancies between words and figures will be resolved in favor of the words.

- 13.02 The Bid price shall include such amounts as the Bidder deems proper for overhead and profit and any account of cash allowances, if any, named in the Contract Documents as provided in Paragraph 11.02 of the General Conditions.

- 13.03 Bid prices will be compared after adjusting for differences in the time designated by Bidders for Substantial Completion. The adjusting amount will be determined at the rate set forth in the Contract Documents for liquidated damages for failing to achieve Substantial Completion for each day before or after the desired date appearing in Article 9.
- 13.04 The contents of the successful IFB/RFP are included as if fully reproduced herein. Therefore, the selected contractor must be prepared to be bound by his/her proposal as submitted.
- 13.05 Whereas the Colleton County Purchasing Ordinance Chapter 3.08 has provisions for Local Vendor preference. Bidders are encouraged to review section 3.08.185 of Chapter 3.08 for their rights under the Local Vendor Preference as this preference could be used in determining the lowest responsible bidder.

ARTICLE 14 - SUBMITTAL OF BID

- 14.01 **A Bidder shall submit one (1) copy of the "Bid Forms". The Bid Forms shall contain the Bid security and a completed W-9 form.**
- 14.02 A Bid must be submitted via email no later than the date and the official time prescribed in the Advertisement or Invitation to Bid and shall be accompanied by the Bid security and other required documents. A Bid must be submitted via email to:
- Kaye B. Syfrett, Procurement Manager at ksyfrett@colletoncounty.org***
- 14.03 In the case of Inclement Weather/Closure of Colleton County offices; If the Colleton County office is closed for business at the time scheduled for bid opening, for whatever reason, emailed bids will be accepted on the next scheduled business day, at the originally scheduled official time.
- 14.04 The Bid shall be submitted on the Bid Form provided; no other form is acceptable.
- 14.05 The successful Bidder will be required to provide verified unit breakdown of costs of all services and work in a manner acceptable to the Owner.
- 14.06 All blanks on the Bid Forms shall be filled in, either typed or printed in ink. The person signing the bid shall initial all corrections or erasures.
- 14.07 Where so indicated on the Bid Form, the Bid Sum shall be expressed in both words and figures; in case of a discrepancy between the two, the Sums expressed in words shall govern.
- 14.08 List unit price on bidder take offs - extend and show total. In case of errors in extension, unit prices shall govern. Unit pricing shall include all applicable overhead, administrative, profit and other associated cost.
- 14.09 Bidder shall quote all Alternates in the Bidding Documents. If Bidder fails to bid on all Alternates, then his/her Bid may be considered irregular, non-responsive and may be disqualified.
- 14.10 Bids containing qualifications will be considered irregular, non-responsive and may be disqualified.

- 14.11 A Bid submitted by a partnership shall list the names of all partners and shall be signed in the partnership name by one of the members of the partnership who is authorized to sign for the partnership.
- 14.12 A Bid submitted by a corporation shall be executed in the legal name of the corporation, followed by the state of incorporation and signed by the President or Vice President or another authorized officer. The name of each person signing the Bid Form shall be typed or printed below the signature.
- 14.13 When the person signing for a corporation is other than the President or Vice President and when requested by the Owner, a resolution or other satisfactory evidence of the authority of the officer signing in behalf of the corporation shall be furnished for the Owner's records. The name of each person signing the Bid Form shall be typed or printed below the signature.

ARTICLE 15 - MODIFICATION OF BID-CLAIM OF ERROR

- 15.01 A Bid may be modified or withdrawn by an appropriate document duly executed in the manner that a Bid must be executed and delivered to the place where Bids are to be submitted prior to the date and time for the opening of Bids.
- 15.02 A bidder may request to have their submitted bid withdrawn due to an error. The claim of error must be submitted within 24 hours of the bid submittal deadline. The description of the nature of the error shall accompany the request. The description shall include all original worksheets, demonstrating the error. If a withdrawal request is approved, the bidders Bid Bond will not be forfeited.

ARTICLE 16 - OPENING OF BIDS

- 16.01 Bids will be opened at the time indicated in the Advertisement or Invitation to Bid. An abstract of the amounts of the base Bids and major alternates, if any, will be made available to Bidders after the opening of Bids in the form of a Bid Tabulation and Bid Comparison to be posted on the County web page.

ARTICLE 17 - BIDS TO REMAIN SUBJECT TO ACCEPTANCE

- 17.01 All Bids will remain subject to acceptance for the period of time stated in the Bid Form, but the Owner may, in its sole discretion, release any Bid and return the Bid security prior to the end of this period.

ARTICLE 18 - EVALUATION OF BIDS AND AWARD OF CONTRACT

- 18.01 The Owner reserves the right to reject any or all Bids, including without limitation, nonconforming, non-responsive, unbalanced, or conditional Bids. The Owner further reserves the right to reject the Bid of any Bidder whom it finds, after reasonable inquiry and evaluation, to not be responsible. The Owner may also reject the Bid of any Bidder if the Owner believes that it would not be in the best

interest of the Project to make an award to that Bidder. The Owner also, reserves the right to waive all informalities not involving price, time, or changes in the Work and to negotiate contract terms with the Successful Bidder.

- 18.02 More than one Bid for the same Work from an individual or entity under the same or different names will not be considered. Reasonable grounds for believing that any Bidder has an interest in more than one Bid for the Work may be cause for disqualification of that Bidder and the rejection of all Bids in which that Bidder has an interest.
- 18.03 In evaluating Bids, the Owner will consider whether or not the Bids comply with the prescribed requirements, and such alternates, unit prices and other data, as may be requested in the Bid Form or prior to the Notice of Award.
- 18.04 In evaluating Bidders, the Owner will consider the qualifications of Bidders and may consider the qualifications and experience of Subcontractors, Suppliers, and other individuals or entities proposed for those portions of the Work for which the identity of Subcontractors, Suppliers, and other individuals or entities must be submitted as provided in the General Conditions.
- 18.05 The Owner may conduct such investigations as the Owner deems necessary to establish the responsibility, qualifications, and financial ability of Bidders, proposed Subcontractors, Suppliers, individuals, or entities to perform the Work in accordance with the Contract Documents.
- 18.06 If the Contract is to be awarded, the Owner will award the Contract to the Bidder whose Bid is in the best interests of the Project.
- 18.07 The Owner reserves the right not to Award the Project.
- 18.08 The Owner shall have the right to accept Alternates in any order or combination, and to determine the low bidder on the basis of the sum of the Base Bid and alternates accepted.

ARTICLE 19 - CONTRACT SECURITY AND INSURANCE

- 19.01 Article 5 of the General Conditions sets forth the Owner's requirements as to performance and payment bonds and insurance. When the Successful Bidder delivers the executed Agreement to the Owner, it shall be accompanied by such bonds.

ARTICLE 20 - SIGNING OF AGREEMENT

- 20.01 When the Owner gives a Notice of Award to the Successful Bidder, it shall be accompanied by the required number of unsigned counterparts of the Agreement with the other Contract Documents which are identified in the Agreement as attached thereto. Within seven (7) days thereafter, Successful Bidder shall sign and deliver the required number of counterparts of the Agreement and attached documents to the Owner. Within seven (7) days thereafter, the Owner shall deliver one (1) fully signed counterpart to Successful Bidder with a complete set of the Drawings with appropriate identification.

ARTICLE 21 - RETAINAGE

21.01 Retainage from progress payments to the Contractor shall be **ten percent** (10%) of each payment for work completed and stored materials on site. Upon substantial completion, contractor may request in a payment application, five percent 5% of the held retainage.

ARTICLE 22 – INSURANCE

22.01 The successful bidder shall procure, maintain, and provide proof of, insurance coverage for injuries to persons and/or property damage as may arise from or in conjunction with, the work performed on behalf of the County by the bidder, his agents, representatives, employees or subcontractors. Proof of coverage as contained herein shall be submitted fifteen (15) days prior to the commencement of work and such coverage shall be maintained by the bidder for the duration of the contract period; for occurrence policies.

a. General Liability

Coverage shall be as broad as: Comprehensive General Liability endorsed to include Broad Form, Commercial General Liability form including Products/Completed Operations.

Minimum Limits

General Liability:

\$2,000,000 General Aggregate

\$2,000,000 Products & Completed Operations Aggregate

\$1,000,000 Personal and Advertising Injury

\$1,000,000 Each Occurrence (Bodily Injury and Property Damage)

\$50,000 Fire Damage Limit

\$5,000 Medical Expense Limit

b. Automobile Liability

Coverage sufficient to cover all vehicles owned, used, or hired by the bidder, his agents, representatives, employees or subcontractors.

Minimum Limits

Automobile Liability:

\$1,000,000 Combined Single Limit

\$1,000,000 Each Occurrence

Limit \$5,000 Medical Expense

c. Workers' Compensation

Limits as required by the Workers' Compensation Act of SC. Employers

Liability, \$1,000,000

d. Owners' & Contractors' Protective Liability

Policy will be in name of Colleton County.

Minimum limits required are \$1,000,000

e. Excess or Umbrella Liability

General Aggregate \$2,000,000

| | | |
|--------------------------|------------------|-------------|
| | Each Occurrence | \$2,000,000 |
| f. Contractual Liability | | |
| Bodily Injury: | | |
| | Each Accident | \$2,000,000 |
| | Annual Aggregate | \$2,000,000 |
| Property Damage: | | |
| | Each Accident | \$2,000,000 |
| | Annual Aggregate | \$2,000,000 |

g. Coverage Provisions

1. All deductibles or self-insured retention shall appear on the certificate(s).
2. The County of Colleton, its officers/ officials, employees, agents and volunteers shall be added as "additional insured" as their interest's may appear. This provision does not apply to Professional Liability or Workers' Compensation/Employers' Liability.
3. The bidder's insurance shall be primary over any applicable insurance or self-insurance maintained by Colleton County.
4. Shall provide 30 days' written notice to Colleton County before any cancellation, suspension, or void of coverage in whole or part, where such provision is reasonable.
5. All coverage for subcontractors of the bidder shall be subject to all of the requirements stated herein.
6. All deductibles or self-insured retention shall appear on the certificate(s) and shall be subject to approval by the County. At the option of Colleton County, either; the insurer shall reduce or eliminate such deductible or self-insured retention; or the bidder shall be required to procure a bond guaranteeing payment of losses and related claims expenses.
7. Failure to comply with any reporting provisions of the policy(s) shall not affect coverage provided Colleton County, its officers/officials, agents, employees and volunteers.
8. The insurer shall agree to waive all rights of subrogation against Colleton County, its' Officers/officials, agents, employees or volunteers for any act, omission or condition of premises which the parties may be held liable by reason of negligence.
9. The bidder shall furnish Colleton County certificates of insurance including endorsement affecting coverage. The certificates are to be signed by a person authorized by the insurance company(s) to bind coverage on its' behalf, if executed by a broker, notarized copy of authorization to bind, or certify coverage must be attached.
10. All insurance shall be placed with insurers maintaining an A.M. Best rating of no less than an A: VII. If A.M. Best rating is less than A: VII, approval must be received from Colleton County's Risk Officer.

- 22.02 Colleton County, SC will require each contractor and service provider to maintain on file with the Procurement Manager, a current Certificate of Insurance showing limits as required by the Workers' Compensation Act of SC:

Employers Liability, \$1,000,000.

The law also recognizes "statutory employees." These are employees who work for a subcontractor who may be working for a business or another contractor. Employers should inquire whether or not a subcontractor working for them has workers' compensation insurance, regardless of the number of employees employed by the subcontractor. If the subcontractor does not, the subcontractor's injured employees would be covered under the employer's workers' compensation insurance. If the subcontractor does not carry workers' compensation insurance, then the owner or the principal contractor would be liable just as if the subcontractor's employee was one of their employees. For answers to additional questions, visit the SC Worker's Compensation Commission website at:
<http://www.wcc.state.sc.us/Frequently%20Asked%20Questions/FAQ.htm>

- 22.03 Contractor shall provide and maintain, during the progress of the work and until execution of the Certificate of Contract Completion, a Builder's Risk Insurance policy to cover all work in the course of construction including false work, temporary buildings, scaffolding, and materials used in the construction process (including materials designated for the project but stored off site or in transit). The coverage shall equal the total completed value of the work and shall provide recovery at replacement cost.

- a) Such insurance shall be on a special cause of loss form, providing coverage on an open perils basis insuring against the direct physical loss of or damage to covered property, including but not limited to theft, vandalism, malicious mischief, earthquake, tornado, lightning, and explosion, breakage of glass, collapse, water damage, and testing /startup.
- b) Coverage shall include coverage for "soft costs" (costs other than replacement of building materials) including, but not limited to, the reasonable extra costs of the architect/engineer and reasonable Contractor extension or acceleration costs. This coverage shall also include the reasonable extra costs of expediting temporary and permanent repairs to, or permanent replacement of, damaged property. This shall include overtime wages and the extra cost of express or other means for rapidly transporting materials and supplies necessary to the repair or replacement.
- c) The policy shall specifically permit and allow for partial occupancy by the owner prior To execution of the final Certification of Contract Completion, and coverage shall remain in effect until all punch list items are completed.
- d) The Builder's Risk deductible may not exceed \$5,000. The Contractor or subcontractor experiencing any loss claimed under the Builder's Risk policy shall be responsible for that loss up to the amount of the deductible.
- e) If Contractor is involved solely in the installation of material and equipment and not in new building construction, the Contractor shall provide an Installation Floater policy in lieu of a Builder's Risk policy. The policy must comply with the provisions of this paragraph.

ARTICLE 23 – WARRANTY

- 23.01 Warranty of workmanship and products shall be covered for **730 days** from the date of the issuance of the Certificate of Substantial Completion. During the 730-day warranty period, all product warranties or workmanship repairs are the sole responsibility of the Contract holder and shall include all parts and labor associated with the repair.
- 23.02 All items repaired or replaced during the initial Warranty period due to workmanship or product failure shall be warranted for 365 days from the date of the repair and or replacement.
- 23.03 All Surety Bonds shall cover the warranty period listed in 23.01 and 23.02. The surety shall be updated to reconcile the date of the warranty period as needed.
- 23.04 Should a product installed during the construction process not have a manufactures warranty period that extends out to one year, it is the responsibility of the Contract holder to cover the product and any resulting expenses related to that product for one year.

The remainder of this page was intentionally left blank

CONTRACT

THIS AGREEMENT is by and between Colleton County, 109 Benson Street.,
Walterboro, South Carolina 29488

(hereinafter called "Owner") and _____

doing business as an **individual/partnership/corporation/joint venture** (strike out inapplicable terms), with its primary office in the City of _____, County of _____, State of _____.

The Owner and Contractor, in consideration of the mutual covenants set forth herein, agree as follows:

ARTICLE 1 - WORK

1.01 Contractor shall complete all Work as specified or indicated in the Contract Documents. The Work is generally described as follows:

Renovation of the current Technology Dept. workspace in the Harrelson Building at 31 Klein Street, Walterboro, SC 29488. The project includes a new network workspace, office space renovation, technology support systems, applicable equipment, and 1st-floor corridor improvements.

ARTICLE 2 - THE PROJECT

2.01 The Project for which the Work under the Contract Documents may be the whole or only a part is generally described as follows:

Renovation of the current Technology Dept. workspace in the Harrelson Building at 31 Klein Street, Walterboro, SC 29488. The project includes a new network workspace, office space renovation, technology support systems, applicable equipment, and 1st-floor corridor improvements.

ARTICLE 3 - DESIGN

3.01 The Project has been designed by: Glick, Boehm Architecture Inc., Doug Clark, will act as the Construction Coordinator as the Owner's representative, assume all duties and responsibilities, and have the rights and authority assigned to the Construction Coordinator in the Contract Documents in connection with the completion of the Work in accordance with the Contract Documents.

ARTICLE 4 - CONTRACT TIMES

4.01 Time of the Essence

A. All time limits for Milestones for final payment as stated in the Contract Documents are of the essence of the Contract.

4.02 Dates for Substantial Completion and Final Payment

Renovation of the current Technology Dept. workspace in the Harrelson Building at 31 Klein Street, Walterboro, SC 29488. The project includes a new network workspace, office space renovation, technology support systems, applicable equipment, and 1st-floor corridor

improvements to be completed within Two Hundred Seventy (270) calendar days after the "Notice to Proceed" has been issued.

4.03 Liquidated Damages

- A. Contractor and the Owner recognize that time is of the essence of this Agreement and that the Owner will suffer financial loss if the Work is not completed within the times specified in Paragraph 4.02 above, plus any extensions thereof allowed in accordance with Article 12 of the General Conditions. The parties also recognize the delays, expense, and difficulties involved in proving in a legal or arbitration proceeding the actual loss suffered by the Owner if the Work is not completed on time. Accordingly, instead of requiring any such proof, the Owner and Contractor agree that as liquidated damages for delay (but not as a penalty), Contractor shall pay the Owner \$500 for each day that expires after the time specified in Paragraph 4.02 for completion and readiness for final payment until the Work is completed and ready for final payment.
- B. Liquidated damages can and will be assessed against the final payment request and any retainage held by Colleton County. Should funding for Liquidated damages exceed the amount held by Colleton County in the form of Payments or Retainage, work shall stop until such time as the Liquidated Damages issue is resolved.
- C. Substantial Completion does not constitute compliance with the allotted time as outlined in the bid packet or within the Contract Documents.

ARTICLE 5 - CONTRACT PRICE

5.01 The Owner shall pay Contractor for completion of the Work in accordance with the Contract Documents an amount in current funds equal to the sum of the amounts determined pursuant to Paragraphs 5.01.A below:

- A. For all Unit Price Work, an amount equal to the sum of the established unit price for each separately identified item of Unit Price Work, times the estimated quantity of that item as indicated in the Bid Form attached hereto as part of these Contract Documents.
- B. Allowances to be used at the owner's discretion shall be included in Base Bid Proposal. Allowances will be listed separately in the submitted schedule of values and unit price sheet. All unused allowances shall be credited back to the owner at the completion of the project in the form of a change order.

| | | | |
|------------------|----|---|--------------|
| Unfounded issues | LS | 1 | \$ 50,000.00 |
|------------------|----|---|--------------|

C. The sum of unit price work to be completed as noted in 5.01(A) and 5.01(B) is,

_____ \$ _____.

ARTICLE 6 - PAYMENT PROCEDURES

6.01 Submittal and Processing of Payments

- A. Contractor shall submit Applications for Payment in accordance with Article 14 of the General Conditions. Applications for Payment will be processed by the Construction Coordinator as provided in the General Conditions.

6.02 Progress Payments; Retainage

- A. The Owner shall make progress payments on account of the Contract Price on the basis of Contractor's Applications for Payment on or about the 15th day of each month during performance of the Work as provided in Paragraphs 6.02.A.1 and 6.02.A.2 below. All such payments will be measured by the schedule of values established as provided in Paragraph 2.07.A of the General Conditions (and in the case of Unit Price Work based on the number of units completed) or, in the event there is no schedule of values, as provided in the General Requirements:
1. Prior to Substantial Completion, progress payments will be made in an amount equal to the percentage indicated below but, in each case, less the aggregate of payments previously made and less such amounts as the Construction Coordinator may determine or the Owner may withhold, including but not limited to liquidated damages, in accordance with Paragraph 14.02 of the General Conditions:
 - a. **90%** of Work completed (with the balance being Retainage).
 - b. **90%** of cost of materials and equipment not incorporated in the Work (with the balance being Retainage).
 2. Upon Substantial Completion, the Owner shall pay an amount sufficient to increase total payments to Contractor to **95%** of the Work completed, less such amounts as the Construction Coordinator shall determine in accordance with Paragraph 14.02.B.5 of the General Conditions and less **10%** of the Construction Coordinator estimate of the value of Work to be completed or corrected as shown on the tentative list of items to be completed or corrected attached to the certificate of Substantial Completion.

6.03 Final Payment

- A. Upon final completion and acceptance of the Work in accordance with Paragraph 14.07 of the General Conditions, the Owner shall pay the remainder of the Contract Price as recommended by the Construction Coordinator as provided in said Paragraph 14.07.

ARTICLE 7 – CONTRACTOR'S REPRESENTATIONS

- 7.01 In order to induce the Owner to enter into this Agreement Contractor makes the following representations:
- A. Contractor has examined and carefully studied the Contract Documents and the other related data identified in the Bidding Documents.
 - B. Contractor has visited the Site and become familiar with and is satisfied as to the general, local, and Site conditions that may affect cost, progress, and performance of the Work.
 - C. Contractor is familiar with and is satisfied as to all federal, state, and local Laws and Regulations that may affect cost, progress, and performance of the Work.
 - D. Contractor has carefully studied all: (1) reports of explorations and tests of subsurface conditions at or contiguous to the Site and all drawings of physical conditions in or relating to existing surface or subsurface structures at or contiguous to the Site (except Underground Facilities) which have been identified in Paragraph 4.02 of the General Conditions and (2) reports and drawings of a Hazardous Environmental Condition, if any, at the Site which has been identified in Paragraph 4.06 of the General Conditions.
 - E. Contractor has obtained and carefully studied (or assumes responsibility for doing so) all examinations, investigations, explorations, tests, studies, and data concerning conditions (surface, subsurface, and Underground Facilities) at or contiguous to the Site which may affect

cost, progress, or performance of the Work or which relate to any aspect of the means, methods, techniques, sequences, and procedures of construction to be employed by Contractor, including any specific means, methods, techniques, sequences, and procedures of construction expressly required by the Bidding Documents, and safety precautions and programs incident thereto.

- F. Contractor does not consider that any further examinations, investigations, explorations, tests, studies, or data are necessary for the performance of the Work at the Contract Price, within the Contract Times, and in accordance with the other terms and conditions of the Contract Documents.
- G. Contractor is aware of the general nature of work to be performed by the Owner and others at the Site that relates to the Work as indicated in the Contract Documents.
- H. Contractor has correlated the information known to Contractor, information and observations obtained from visits to the Site, reports and drawings identified in the Contract Documents, and all additional examinations, investigations, explorations, tests, studies, and data with the Contract Documents.
- I. Contractor has given the Owner written notice of all conflicts, errors, ambiguities, or discrepancies that Contractor has discovered in the Contract Documents, and the written resolution thereof by the Owner is acceptable to Contractor.
- J. The Contract Documents are generally sufficient to indicate and convey understanding of all terms and conditions for performance and furnishing of the Work.

ARTICLE 8 - CONTRACT DOCUMENTS

- 8.01 A. The Contract Documents shall consist of all sections in the following divisions;

DIVISION 000 - BIDDING AND CONTRACT REQUIREMENTS
DIVISION 001 - GENERAL CONDITIONS
DIVISION 00 - INTRODUCTORY INFORMATION
DIVISION 01 - GENERAL REQUIREMENTS
DIVISION 02 - SITE CONSTRUCTION
DIVISION 06 - WOOD AND PLASTIC
DIVISION 07 - THERMAL AND MOISTURE PROTECTION
DIVISION 08 - DOORS AND WINDOWS
DIVISION 09 - FINISHES
DIVISION 23 - HEATING, VENTILATING AND AIR CONDITIONING
DIVISION 26 – ELECTRICAL
DIVISION 27 – COMMUNICATIONS
DIVISION 28 – ELCTRONIC SAFTEY AND SECURITY
EXHIBIT "A" - PLANS
EXHIBIT "B" - SPECIFICATIONS

All information contained within these Divisions, and the requirements thereof are of the sole responsibility of the bidder.

- B. There are no Contract Documents other than those listed above in this Article 8.
- C. The Contract Documents may only be amended, modified, or supplemented as provided in Paragraph 3.04 of the General Conditions.

ARTICLE 9 - MISCELLANEOUS

- 9.01 Terms

A. Terms used in this Agreement will have the meanings stated in the 001, General Conditions.

9.02 Assignment of Contract

A. No assignment by a party hereto of any rights under or interests in the Contract will be binding on another party hereto without the written consent of the party sought to be bound; and, specifically but without limitation, moneys that may become due and moneys that are due may not be assigned without such consent (except to the extent that the effect of this restriction may be limited by law), and unless specifically stated to the contrary in any written consent to an assignment, no assignment will release or discharge the assignor from any duty or responsibility under the Contract Documents.

9.03 Successors and Assigns

A. The Owner and Contractor each binds itself, its partners, successors, assigns, and legal representatives to the other party hereto, its partners, successors, assigns, and legal representatives in respect to all covenants, agreements, and obligations contained in the Contract Documents.

9.04 Severability

A. Any provision or part of the Contract Documents held to be void or unenforceable under any Law or Regulation shall be deemed stricken, and all remaining provisions shall continue to be valid and binding upon the Owner and Contractor, who agree that the Contract Documents shall be reformed to replace such stricken provision or part thereof with a valid and enforceable provision that comes as close as possible to expressing the intention of the stricken provision.

9.05 Waiver or Forbearance

A. Any delay or failure of Colleton County to insist upon strict performance of any obligation under this Agreement or to exercise any right or remedy provided under this Agreement shall not be a waiver of Colleton County's right to demand strict compliance, irrespective of the number or duration of any delay(s) or failure(s). No term or condition imposed on Contractor under this Agreement shall be waived and no breach by Contractor shall be excused unless that waiver or excuse of a breach has been put in writing and signed by both parties. No waiver in any instance of any right or remedy shall constitute waiver of any other right or remedy under this Agreement. No consent to or forbearance of any breach or substandard performance of any obligation under this Agreement shall constitute consent to modification or reduction of the other obligations or forbearance of any other breach.

9.06 Subject to the provisions below, the contract may be terminated by Colleton County upon fifteen (15) days advance written notice to the other party; but if any work or service hereunder is in progress, but not completed as of the date of termination, then this contract may be extended upon written approval of the County until said work or services are completed and accepted.

a. Termination for Convenience

In the event that this contract is terminated or canceled upon request and for the convenience of the County, without the required fifteen (15) days advance written notice, then the County shall negotiate reasonable termination costs, if applicable.

b. Termination for Cause

Termination by the County for cause, default or negligence on the part of the Contractor shall be excluded from the foregoing provision; termination costs if any, shall not apply. The fifteen (15) days advance notice requirement is waived in the event of Termination for Cause.

c. Non-Appropriation:

It is understood and agreed by the parties that in the event funds are not Appropriated in the current fiscal year or any subsequent fiscal years, this contract will become null and void and the County will only be required to pay for services completed to the satisfaction of the County.

IN WITNESS, WHEREOF, the Owner and Contractor have signed this Agreement. One counterpart each has been delivered to the Owner, Contractor, Construction Coordinator and provided to the Contractor for his Bonding Agency. All portions of the Contract Documents have been signed or identified by the Owner and Contractor or on their behalf.

This Agreement will be effective on this ____ day of _____, 2023 (which is the Effective Date of the Agreement).

OWNER:

CONTRACTOR:

Colleton County

By:

J. Kevin Griffin

Title:

County Administrator

Attest:

Title:

Address for giving notices:

Colleton County Purchasing Department

Attn: Kaye Syfrett, Procurement Manager

113 Mable T. Willis Boulevard

Walterboro, SC, 29488

By:

Title:

Attest:

Title:

Address for giving notices:

License No.:

(Where applicable)

The remainder of this page was intentionally left blank



REFERENCE FORMS

1- BOND FORMS

Bond Requirements

- a. All Bonds shall be placed with insurers maintaining an A.M. Best rating of no less than an A: VII. If A.M. Best rating is less than A: VII, approval must be received from Colleton County's Risk or Finance Officer before issuance.
- b. Bonding Companies shall submit as proof of good standing, a copy of the A.M Rating along with the Bond.
- c. Bonding/Surety Companies shall use the Bonds provided in the Bid/Proposal Packet CC-38.
- d. Bonding/Surety Companies shall issue a new Performance Bond and Payment Bond at such time that the contract has been altered by a change order adjusting the compensation of the contract.
- e. Bonding companies shall note the warranty periods as outlined in the Proposal Document CC-38 and listed on the reverse side of the bond itself. Should the warranty period be extended past the initial contract period due to a warranty claim, then the bond shall will be re-issued to match the new warranty period as outlined in the proposal documents.

The remainder of this page was intentionally left blank

PERFORMANCE BOND

Any singular reference to Contractor, Surety, the Owner, or other party shall be considered plural where applicable.

CONTRACTOR: _____ SURETY: _____

OWNER: Colleton County
109 Benson Street
Walterboro, SC 29488

CONTRACT: CC-38

Date: _____

Amount: _____

Description (Name and Location): **Renovation of the current Technology Dept. workspace in the Harrelson Building at 31 Klein Street, Walterboro, SC 29488. The project includes a new network workspace, office space renovation, technology support systems, applicable equipment, and 1st-floor corridor improvements.**

BOND

Bond Number: _____

Date (Not earlier than Contract Date): _____

Amount: _____

Modifications to this Bond Form: _____

Surety and Contractor, intending to be legally bound hereby, subject to the terms printed on the reverse side hereof, do each cause this Performance Bond to be duly executed on its behalf by its authorized officer, agent, or representative.

CONTRACTOR AS PRINCIPAL
Company: _____

Signature: _____
Name and Title: _____

SURETY

Surety's Name and Corporate Seal

By: _____
Signature and Title
(Attach Power of Attorney)

Attest: _____
Signature and Title

(Space is provided below for signatures of additional parties, if required.)

CONTRACTOR AS PRINCIPAL
Company: _____

Signature: _____

Name and Title: _____

SURETY

Surety's Name and Corporate Seal

By: _____
Signature and Title
(Attach Power of Attorney)

Attest: _____
Signature and Title:

1. Contractor and Surety, jointly and severally, bind themselves, their heirs, executors, administrators, successors, and assigns to Owner for the performance of the Contract, which is incorporated herein by reference.
2. If Contractor performs the Contract, Surety and Contractor have no obligation under this Bond, except to participate in conferences as provided in Paragraph 3.1.
3. If there is no Owner Default, Surety's obligation under this Bond shall arise after:
 - 3.1. Owner has notified Contractor and Surety, at the addresses described in Paragraph 10 below, that Owner is considering declaring a Contractor Default and has requested and attempted to arrange a conference with Contractor and Surety to be held not later than 15 days after receipt of such notice to discuss methods of performing the Contract. If Owner, Contractor and Surety agree, Contractor shall be allowed a reasonable time to perform the Contract, but such an agreement shall not waive Owner's right, if any, subsequently to declare a Contractor Default; and
 - 3.2. Owner has declared a Contractor Default and formally terminated Contractor's right to complete the Contract. Such Contractor Default shall not be declared earlier than 20 days after Contractor and Surety have received notice as provided in Paragraph 3.1; and
 - 3.3. Owner has agreed to pay the Balance of the Contract Price to:
 1. Surety in accordance with the terms of the Contract;
 2. Another contractor selected pursuant to Paragraph 4.3 to perform the Contract.
4. When Owner has satisfied the conditions of Paragraph 3, Surety shall promptly and at Surety's expense take one of the following actions:
 - 4.1. Arrange for Contractor, with consent of Owner, to perform and complete the Contract; or
 - 4.2. Undertake to perform and complete the Contract itself, through its agents or through independent contractors; or
 - 4.3. Obtain bids or negotiated proposals from qualified contractors acceptable to Owner for a contract for performance and completion of the Contract, arrange for a contract to be prepared for execution by Owner and Contractor selected with Owner's concurrence, to be secured with performance and payment bonds executed by a qualified surety equivalent to the bonds issued on the Contract, and pay to Owner the amount of damages as described in Paragraph 6 in excess of the Balance of the Contract Price incurred by Owner resulting from Contractor Default; or
 - 4.4. Waive its right to perform and complete, arrange for completion, or obtain a new contractor and with reasonable promptness under the circumstances:
 1. After investigation, determine the amount for which it may be liable to Owner and, as soon as practicable after the amount is determined, tender payment therefor to Owner; or
 2. Deny liability in whole or in part and notify Owner citing reasons therefor.
5. If Surety does not proceed as provided in Paragraph 4 with reasonable promptness, Surety shall be deemed to be in default on this Bond 15 days after receipt of an additional written notice from Owner to Surety demanding that Surety perform its obligations under this Bond, and Owner shall be entitled to enforce any remedy available to Owner. If Surety proceeds as provided in Paragraph 4.4, and Owner refuses the payment tendered or Surety has denied liability, in whole or in part, without further notice Owner shall be entitled to enforce any remedy available to Owner.
6. After Owner has terminated Contractor's right to complete the Contract, and if Surety elects to act under Paragraph 4.1, 4.2, or 4.3 above, then the responsibilities of Surety to Owner shall not be greater than those of Contractor under the Contract, and the responsibilities of Owner to Surety shall not be greater than those of Owner under the Contract. To a limit of the amount of this Bond, but subject to commitment by Owner of the Balance of the Contract Price to mitigation of costs and damages on the Contract, Surety is obligated without duplication for:
 - 6.1. The responsibilities of Contractor for correction of defective Work and

completion of the Contract;

- 6.2. Additional legal, design professional, and delay costs resulting from Contractor's Default, and resulting from the actions or failure to act of Surety under Paragraph 4; and
 - 6.3. Liquidated damages, or if no liquidated damages are specified in the Contract, actual damages caused by delayed performance or non-performance of Contractor.
7. Surety shall not be liable to Owner or others for obligations of Contractor that are unrelated to the Contract, and the Balance of the Contract Price shall not be reduced or set off on account of any such unrelated obligations. No right of action shall accrue on this Bond to any person or entity other than Owner or its heirs, executors, administrators, or successors.
 8. Surety hereby waives notice of any change, including changes of time, to Contract, Contract amount or to related subcontracts, purchase orders, and other obligations.
 9. Any proceeding, legal or equitable, under this Bond may be instituted in any court of competent jurisdiction in the location in which the Work or part of the Work is located and shall be instituted within two years after Contractor Default or within two years after Contractor ceased working or within two years after Surety refuses or fails to perform its obligations under this Bond, whichever occurs first. If the provisions of this paragraph are void or prohibited by law, the minimum period of limitation available to sureties as a defense in the jurisdiction of the suit shall be applicable.
 10. Notice to Surety, Owner, or Contractor shall be mailed or delivered to the address shown on the signature page.
 11. When this Bond has been furnished to comply with a statutory requirement in the location where the Contract was to be performed, any provision in this Bond conflicting with said statutory requirement shall be deemed deleted here from and provisions conforming to such statutory requirement shall be deemed incorporated herein. The intent is that this Bond shall be construed as a statutory bond and not as a common law bond.
 12. The Surety will be obligated until such time as the Contractor has faithfully performed all terms of the Contract, which includes a two (2) year warranty coverage period.
 - 12.1 The standard two-year warranty period starts on the date of issuance of the Substantial Completion Certification.
 - 12.2 The standard warranty covers the full cost of Labor, Parts, Shipping, Sales Tax and any and all other associated cost for the warranty repair.
 - 12.3 The surety agrees that should a warranty issue arise within the allotted standard two (2) year warranty period, the item repaired during the warranty period shall be covered for an addition year (365 days) from the completed repair of the warranty issue.
 13. Definitions
 - 13.1 Balance of the Contract Price: The total amount payable by Owner to Contractor under the Contract after all proper adjustments have been made, including allowance to Contractor of any amounts received or to be received by Owner in settlement of insurance or other Claims for damages to which Contractor is entitled, reduced by all valid and proper payments made to or on behalf of Contractor under the Contract.
 - 13.2 Contract: The agreement between Owner and Contractor identified on the signature page, including all Contract Documents and changes thereto.
 - 13.3 Contractor Default: Failure of Contractor, which has neither been remedied nor waived, to perform or otherwise to comply with the terms of the Contract.
 - 13.4 Owner Default: Failure of Owner, which has neither been remedied nor waived, to pay Contractor as required by the Contract or to perform and complete or comply with the other terms thereof.

PAYMENT BOND

Any singular reference to Contractor, Surety, the Owner, or other party shall be considered plural where applicable.

CONTRACTOR:

SURETY:

OWNER: Colleton County
109 Benson Street
Walterboro, SC 29488

CONTRACT: CC-38

Date: _____

Amount: _____

Description (Name and Location): **Renovation of the current Technology Dept. workspace in the Harrelson Building at 31 Klein Street, Walterboro, SC 29488. The project includes a new network workspace, office space renovation, technology support systems, applicable equipment, and 1st-floor corridor improvements.**

BOND

Bond Number: _____

Date (Not earlier than Contract Date): _____

Amount: _____

Modifications to this Bond Form: _____

Surety and Contractor, intending to be legally bound hereby, subject to the terms printed on the reverse side hereof, do each cause this Payment Bond to be duly executed on its behalf by its authorized officer, agent, or representative.

CONTRACTOR AS PRINCIPAL

SURETY

Company: _____

Signature: _____
Name and Title:

Surety's Name and Corporate Seal

By: _____
Signature and Title
(Attach Power of Attorney)

(Space is provided below for signatures of additional parties, if required.)

Attest: _____
Signature and Title

CONTRACTOR AS PRINCIPAL

SURETY

Company:

Signature: _____
Name and Title:

Surety's Name and Corporate Seal

By: _____
Signature and Title
(Attach Power of Attorney)

Attest: _____

1. Contractor and Surety, jointly and severally, bind themselves, their heirs, executors, administrators, successors, and assigns to Owner to pay for labor, materials, and equipment furnished by Claimants for use in the performance of the Contract, which is incorporated herein by reference.
 2. With respect to Owner, this obligation shall be null and void if Contractor:
 - 2.1. Promptly makes payment, directly or indirectly, for all sums due Claimants, and
 - 2.2. Defends, indemnifies, and holds harmless Owner from all claims, demands, liens, or suits alleging non-payment by Contractor by any person or entity who furnished labor, materials, or equipment for use in the performance of the Contract, provided Owner has promptly notified Contractor and Surety (at the addresses described in Paragraph 12) of any claims, demands, liens, or suits and tendered defense of such claims, demands, liens, or suits to Contractor and Surety, and provided there is no Owner Default.
 3. With respect to Claimants, this obligation shall be null and void if Contractor promptly makes payment, directly or indirectly, for all sums due.
 4. Surety shall have no obligation to Claimants under this Bond until:
 - 4.1. Claimants who are employed by or have a direct contract with Contractor have given notice to Surety (at the addresses described in Paragraph 12) and sent a copy, or notice thereof, to Owner, stating that a claim is being made under this Bond and, with substantial accuracy, the amount of the claim.
 - 4.2. Claimants who do not have a direct contract with Contractor:
 1. Have furnished written notice to Contractor and sent a copy, or notice thereof, to Owner, within 90 days after having last performed labor or last furnished materials or equipment included in the claim stating, with substantial accuracy, the amount of the claim and the name of the party to whom the materials or equipment were furnished or supplied, or for whom the labor was done or performed; and
 2. Have either received a rejection in whole or in part from Contractor, or not received within 30 days of furnishing the above notice any communication from Contractor by which Contractor had indicated the claim will be paid directly or indirectly; and
 3. Not having been paid within the above 30 days, have sent a written notice to Surety and sent a copy, or notice thereof, to Owner, stating that a claim is being made under this Bond and enclosing a copy of the previous written notice furnished to Contractor.
 5. If a notice by a Claimant required by Paragraph 4 is provided by Owner to Contractor or to Surety that is sufficient compliance.
 6. When a Claimant has satisfied the conditions of Paragraph 4, the Surety shall promptly and at Surety's expense take the following actions:
 - 6.1. Send an answer to that Claimant, with a copy to Owner, within 45 days after receipt of the claim, stating the amounts that are undisputed and the basis for challenging any amounts that are disputed.
 - 6.2. Pay or arrange for payment of any undisputed amounts.
 7. Surety's total obligation shall not exceed the amount of this Bond, and the amount of this Bond shall be credited for any payments made in good faith by Surety.
 8. Amounts owed by Owner to Contractor under the Contract shall be used for the performance of the Contract and to satisfy claims, if any, under any performance bond. By Contractor furnishing and Owner accepting this Bond, they agree that all funds earned by Contractor in the performance of the Contract are dedicated to satisfy obligations of Contractor and Surety under this Bond, subject to Owner's priority to use the funds for the completion of the Work.
 9. Surety shall not be liable to Owner, Claimants, or others for obligations of Contractor that are unrelated to the Contract. Owner shall not be liable for payment of any costs or expenses of any Claimant under this Bond, and shall have under this Bond no obligations to make payments to, give notices on behalf of, or otherwise have obligations to Claimants under this Bond.
 10. Surety hereby waives notice of any change, including changes of time, to the Contract or to related Subcontracts, purchase orders and other obligations.
 11. No suit or action shall be commenced by a Claimant under this Bond other than in a court of competent jurisdiction in the location in which the Work or part of the Work is located or after the expiration of one year from the date (1) on which the Claimant gave the notice required by Paragraph 4.1 or Paragraph 4.2.3, or (2) on which the last labor or service was performed by anyone or the last materials or equipment were furnished by anyone under the Construction Contract, whichever of (1) or (2) first occurs. If the provisions of this paragraph are void or prohibited by law, the minimum period of limitation available to sureties as a defense in the jurisdiction of the suit shall be applicable.
 12. Notice to Surety, Owner, or Contractor shall be mailed or delivered to the addresses shown on the signature page. Actual receipt of notice by Surety, Owner, or Contractor, however accomplished, shall be sufficient compliance as of the date received at the address shown on the signature page.
 13. When this Bond has been furnished to comply with a statutory requirement in the location where the Contract was to be performed, any provision in this Bond conflicting with said statutory requirement shall be deemed deleted here from and provisions conforming to such statutory requirement shall be deemed incorporated herein. The intent is that this Bond shall be construed as a statutory Bond and not as a common law bond.
 14. Upon request of any person or entity appearing to be a potential beneficiary of this Bond, Contractor shall promptly furnish a copy of this Bond or shall permit a copy to be made.
 15. The Surety will be obligated until such time as the Contractor has faithfully performed all terms of the Contract, which includes a two (2) year warranty coverage period.
 - 15.1 The standard two-year warranty period starts on the date of issuance of the Substantial Completion Certification.
 - 15.2 The standard warranty covers the full cost of Labor, Parts, Shipping, Sales Tax and any and all other associated cost for the warranty repair.
 - 15.3 The surety agrees that should a warranty issue arise within the allotted standard two (2) year warranty period, the item repaired during the warranty period shall be covered for an addition year (365 days) from the completed repair of the warranty issue.
- ## 16. DEFINITIONS
- 16.1. Claimant: An individual or entity having a direct contract with Contractor, or with a first-tier subcontractor of Contractor, to furnish labor, materials, or equipment for use in the performance of the Contract. The intent of this Bond shall be to include without limitation in the terms "labor, materials or equipment" that part of water, gas, power, light, heat, oil, gasoline, telephone service, or rental equipment used in the Contract, architectural and engineering services required for performance of the Work of Contractor and Contractor's Subcontractors, and all other items for which a mechanic's lien may be asserted in the jurisdiction where the labor, materials, or equipment were furnished.
 - 16.2. Contract: The agreement between Owner and Contractor identified on the signature page, including all Contract Documents and changes thereto.
 - 16.3. Owner Default: Failure of Owner, which has neither been remedied nor waived, to pay Contractor as required by the Contract or to perform and complete or comply with the other terms thereof.

Substantial Completion

| | | |
|---|---|---|
| <p>Project: Renovation of the current Technology Dept. workspace in the Harrelson Building at 31 Klein Street, Walterboro, SC 29488. The project includes a new network workspace, office space renovation, technology support systems, applicable equipment, and 1st-floor corridor improvements.</p> | <p>Project Owner: Colleton County, 109 Benson Street, Walterboro, SC 29488</p> | <p>Architects Project No.: 1924 Owner Project Number: CC-38</p> |
| <p>Contract: CC-38 Harrelson Building – Technology Dept. Improvements Project</p> | | <p>Date of Contract:</p> |
| <p>Contractor:</p> | | |

This [tentative] [definitive] Certificate of Substantial Completion applies to:

All Work under the Contract Documents: [The following specified portions:

The Work to which this Certificate applies has been inspected by authorized representatives of Owner, Contractor and Engineer and or Architect, and found to be substantially complete. The Date of Substantial Completion of the Project or portion thereof designated above is hereby declared and is also the date of commencement of applicable warranties required by the Contract Documents, except as stated below.

A [tentative] [revised tentative] [definitive] list of items to be completed or corrected, is attached hereto. This list may not be all-inclusive, and the failure to include any items on such list does not alter the responsibility of the Contractor to complete all Work in accordance with the Contract Documents.

The responsibilities between OWNER and CONTRACTOR for security, operation, safety, maintenance, heat, utilities, insurance and warranties shall be as provided in the Contract Documents except as amended as follows:

Amended Responsibilities [Not Amended

Owner's Amended Responsibilities:

Contractor's Amended Responsibilities:

The following documents are attached to and made part of this Certificate:

This Certificate does not constitute an acceptance of Work not in accordance with the Contract Documents nor is it a release of Contractor's obligation to complete the Work in accordance with the Contract Documents.

| | |
|--|------|
| Executed by Construction Coordinator: Glick, Boehm Architecture Inc. | Date |
| Accepted by Contractor: | Date |
| Accepted by Owner: John T. Stieglitz III, Capital Projects Director | Date |

CONTRACTOR'S AFFIDAVIT

The State of _____ Date_____

The County of _____

The City/Town of _____

(Officer's Name) (Officer's Title)

Being duly sworn, deposes and says that _____, has furnished
(Contractor's Name)

all labor and material entering into the: **Renovation of the current Technology Dept. workspace in the Harrelson Building at 31 Klein Street, Walterboro, SC 29488. The project includes a new network workspace, office space renovation, technology support systems, applicable equipment, and 1st-floor corridor improvements.**, called for in the Contract Documents dated _____ with **Colleton County** states further that this officer has full knowledge of all obligations for such labor and materials, which have entered into and become part of that certain project known and designated above, and that this officer further deposes and says that all debts and other obligations for such labor and materials have been fully and completely paid for in good and lawful money of the United States of America and that there are no suits for damages against them proceeding, prospective and/or that there are no suits for damages against them proceeding, prospective, or otherwise, in consequence of their operations on the above said project.

The said _____ will hold the Owners,
(Contractor's Name)

Colleton County, South Carolina blameless of any and all mechanic's liens that may be hereafter entered or filed for record, so as to constitute charge against said premises for work or labor done or materials furnished by them.

IN WITNESS HEREOF, this officer has heretofore put his hand and seal: _____(Seal)
(Officer's Name)

I, _____, Notary Public in and for the above-named County and State do

hereby certify that _____ personally known to me to be the affiant in the foregoing
(Officer's Name)

Affidavit, personally appeared before me this day and, having been duly sworn, deposes and says that the facts set forth in the above Affidavit are true and correct.

WITNESS my hand and seal this _____ day of _____, 2023

(Seal)

Notary Public for the State of _____

My Commission Expires: _____

FIELD ORDER No. _____

Date of Issuance: _____

Effective Date: _____

| | | |
|--|--|---|
| Project: Renovation of the current Technology Dept. workspace in the Harrelson Building at 31 Klein Street, Walterboro, SC 29488. The project includes a new network workspace, office space renovation, technology support systems, applicable equipment, and 1st-floor corridor improvements. | Project Owner: Colleton County, 109 Benson Street, Walterboro, SC 29488 | Architects Project No.: 1924 Owner Project Number: CC-38 |
| Contract: CC-38 Harrelson Building - Technology Dept. Improvements Project | | Date of Contract: |
| Contractor: | | |

Attention:

You are hereby directed to promptly execute this Field Order issued in accordance with General Conditions Paragraph 9.05A, for minor changes in the Work without changes in Contract Price or Contract Times. If you consider that a change in Contract Price or Contract Times is required, please notify the Construction Coordinator immediately and before proceeding with this Work.

Re _____
(Specification Section(s)) (Drawing(s) / Detail(s))

Description:

Attachments:

Construction Coordinator: Doug Clark, Glick Boehm Architecture Inc.

| | |
|---------------------------------------|-------|
| Receipt Acknowledged by (Contractor): | Date: |
|---------------------------------------|-------|

WORK CHANGE DIRECT No. _____

Date of Issuance: _____

Effective Date: _____

| | | |
|--|--|---|
| Project: Renovation of the current Technology Dept. workspace in the Harrelson Building at 31 Klein Street, Walterboro, SC 29488. The project includes a new network workspace, office space renovation, technology support systems, applicable equipment, and 1st-floor corridor improvements. | Project Owner: Colleton County, 109 Benson Street, Walterboro, SC 29488 | Architects Project No.: 1924 Owner Project Number: CC-38 |
|--|--|---|

| | |
|---|-------------------|
| Contract: CC-38 Harrelson Building - Technology Dept. Improvements Project | Date of Contract: |
|---|-------------------|

| | |
|-------------|--|
| Contractor: | |
|-------------|--|

You are directed to proceed promptly with the following change(s):

| Item No. | Description |
|----------|-------------|
| | |
| | |

Attachments (list documents supporting change):

| |
|----------------|
| _____ _____ |
|----------------|

Purpose for Work Change Directive:

- Authorization for Work described herein to proceed on the basis of Cost of the Work due to:
- Non-agreement on pricing of proposed change.
- Necessity to expedite Work described herein prior to agreeing to changes on Contract Price and Contract Time.

Estimated change in Contract Price and Contract Times:

Contract Price \$ _____ (increase/decrease) Contract Time _____ days (increase/decrease)

If the change involves an increase, the estimated amounts are not to be exceeded without further authorization.

| | |
|--|-------|
| Recommended for Approval by Construction Coordinator: Doug Clark, Glick Boehm Architecture Inc. | Date |
| Authorized for Owner by: | Date |
| Accepted for Contractor by: | Date |
| Approved by Funding Agency (if applicable): | Date: |

CHANGE ORDER No. _____

Date of Issuance: _____

Effective Date: _____

| | | |
|--|--|---|
| Project: Renovation of the current Technology Dept. workspace in the Harrelson Building at 31 Klein Street, Walterboro, SC 29488. The project includes a new network workspace, office space renovation, technology support systems, applicable equipment, and 1st-floor corridor improvements. | Project Owner: Colleton County, 109 Benson Street, Walterboro, SC 29488 | Architects Project No.: 1924 Owner Project Number: CC-38 |
| Contract: CC-38 Harrelson Building - Technology Dept. Improvements Project | | Date of Contract: _____ |
| Contractor: _____ | | |

The Contract Documents are modified as follows upon execution of this Change Order:

Description: _____

Attachments: (List documents supporting change): _____

CHANGE IN CONTRACT PRICE:

CHANGE IN CONTRACT TIMES:

Original Contract Price:
 \$ _____

Original Contract Times: Working days Calendar days
 Substantial completion (days or date): _____
 Ready for final payment (days or date): _____

[Increase] [Decrease] from previously approved Change Orders No. _____ to No. _____:
 \$ _____

[Increase] [Decrease] from previously approved Change Orders No. _____ to No. _____:
 Substantial completion (days): _____
 Ready for final payment (days): _____

Contract Price prior to this Change Order:
 \$ _____

Contract Times prior to this Change Order:
 Substantial completion (days or date): _____
 Ready for final payment (days or date): _____

[Increase] [Decrease] of this Change Order:
 \$ _____

[Increase] [Decrease] of this Change Order:
 Substantial completion (days or date): _____
 Ready for final payment (days or date): _____

Contract Price incorporating this Change Order:
 \$ _____

Contract Times with all approved Change Orders:
 Substantial completion (days or date): _____
 Ready for final payment (days or date): _____

RECOMMENDED:

APPROVED:

APPROVED:

By: _____
 Contractor (Authorized Signature)

By: _____
 Colleton County Administrator, J. Kevin Griffin

By: _____
 Colleton County Project Director: John T Stieglitz III

Date: _____

Date: _____

Date: _____

Approved by Funding Agency (if applicable): _____

Date: _____

MATERIAL/PRODUCT SUBSTITUTION REQUEST

Date: _____

We hereby submit for your review, the following PRODUCT SUBSTITUTION of the specified material for the above listed project.

Section: _____

Paragraph: _____

Specified Material: _____

Attached is complete technical data of the PRODUCT SUBSTITUTION. Included is complete information on changes to the Project Manual Documents required by the proposed PRODUCT SUBSTITUTION for its proper installation.

A request constitutes a representation that Trade Contractor:

- Has investigated proposed product and determined that it meets or exceeds quality level of specified product.
- Will provide same warranty for Substitution as for specified product.
- Will coordinate installation and make changes to other work which may be required for the work to be complete with no additional cost to the Owner.
- Waives claims for additional costs or time extension which may subsequently become apparent.
- Will reimburse the Owner and Architect/Engineer for review or redesign services associated with re-approval by authorities having jurisdiction or additional time expended by Architect/Engineer to review information.

It is understood that if the Architect or Engineer approves an approved substitution prior to receipt of bids in accordance with the project timeline, such approval will be set forth in an addendum. Bidders shall not rely upon approvals made in any other manner. If substitution requests are not addressed in the addendum, the substitution request shall be considered not approved. Architect's or Engineers decision of approval or disapproval of proposed substitution shall be final without dispute.

THE UNDERSIGNED Trade Contractor states that the function, appearance, and quality of the PRODUCT SUBSTITUTION are equivalent or superior to the specified item. In addition, I, as the Trade Contractor will assume all responsibility for any impact or delay the review and evaluation of the alternate product may cause. Your approval of the Substitute Product in no way will relieve me as the Trade Contractor of my responsibilities to conform to all requirements of the Contract Documents.

Submitted by: _____

NOTICE OF AWARD

Date _____

| | | |
|---|---|---|
| <p>Project: Renovation of the current Technology Dept. workspace in the Harrelson Building at 31 Klein Street, Walterboro, SC 29488. The project includes a new network workspace, office space renovation, technology support systems, applicable equipment, and 1st-floor corridor improvements.</p> | <p>Project Owner: Colleton County, 109 Benson Street, Walterboro, SC 29488</p> | <p>Architects Project No.: 1924 Owner Project Number: CC-38</p> |
| <p>Contract: CC-38 Harrelson Building - Technology Dept. Improvements Project</p> | | |
| <p>Bidder:</p> | | |
| <p>Bidder's Address: (send Certified Mail, Return Receipt Requested):</p> | | |

You are notified that your Bid dated _____ for the above Contract has been considered. You are the Successful Bidder and are awarded a Contract for Harrelson Building - Technology Dept. Improvements Project

The Contract Price of your Contract is _____ (\$_____).

_____ Copies of each of the Contract Documents (except Drawings) accompany this Notice of Award.

_____ Sets of the Drawings will be delivered separately or otherwise made available to you immediately.

You must comply with the following conditions precedent within ten (10) days of the date you receive this Notice of Award.

1. Deliver to the Owner Two (2) fully executed counterparts of the Contract Documents.
2. Deliver with the executed Contract Documents the Contract security [Bonds] as specified.
3. Other conditions precedent:
None

Failure to comply with these conditions within the time specified will entitle Owner to consider you in default, annul this Notice of Award and declare your Bid security forfeited.

Within seven (7) days after you comply with the above conditions, Owner will return to you one (1) fully executed counterpart of the Contract Documents.

Colleton County
Owner

By: _____
Authorized Signature

Title

Acceptance of Notice

Receipt of the above Notice of Award is hereby acknowledged by _____

On this _____ day of _____, 2023.

Contractor

By: _____
Authorized Signature

Title

NOTICE TO PROCEED

Date _____

| | | |
|--|--|---|
| Project: Renovation of the current Technology Dept. workspace in the Harrelson Building at 31 Klein Street, Walterboro, SC 29488. The project includes a new network workspace, office space renovation, technology support systems, applicable equipment, and 1st-floor corridor improvements. | Project Owner: Colleton County, 109 Benson Street, Walterboro, SC 29488 | Architects Project No.: 1924 Owner Project Number: CC-38 |
| Contract: CC-38 Harrelson Building - Technology Dept. Improvements Project | | |
| Contractor: | | |
| Contractor's Address: [send Certified Mail, Return Receipt Requested] | | |
| | | |
| | | |

You are notified that the Contract Times under the above contract will commence to run on _____ or before that date, you are to start performing your obligations under the Contract Documents. In accordance with Article 4 of the Agreement, the date of Substantial Completion is _____ and the date of readiness for final payment is _____.

Before you may start any Work at the Site, Paragraph 2.01.B of the General Conditions provides that you and Owner must each deliver to the other (with copies to the Construction Coordinator and other identified additional insureds) certificates of insurance which each is required to purchase and maintain in accordance with the Contract Documents.

| | |
|-----------------------------------|---|
| _____ Contractor | _____ Colleton County Owner |
| by: _____ Authorized Signature | Given by: _____ John T. Stieglitz |
| _____ Title | _____ Capital Projects Director Title |
| _____ Date | _____ Date |

Colleton County
APPLICATION FOR PAYMENT

Contractor's Application for Payment No. _____

| | | |
|--|--|---|
| To (Owner): Colleton County, 109 Benson Street, Walterboro, SC | Application Period: | Application Date: |
| Owner Project Number: CC-38 | From (Contractor): | Via (Construction Coordinator) Doug Clark, Glick Boehm Arch. |
| Architects Project No.: 1924 | Contractor's Project No.: | |
| Project: Renovation of the current Technology Dept. workspace in the Harrelson Building at 31 Klein Street, Walterboro, SC 29488. The project includes a new network workspace, office space renovation, technology support systems, applicable equipment, and 1st-floor corridor improvements. | Contract: On | |
| | Schedule: Yes _____ No _____ | |
| | Original days: 270 Revised: _____ | |
| | Remaining: _____ | |

Change Order Summary

| Approved Change Orders | | |
|--------------------------------|-----------|------------|
| Number | Additions | Deductions |
| | | |
| | | |
| | | |
| | | |
| | | |
| | | |
| | | |
| | | |
| TOTALS | | |
| NET CHANGE BY CHANGE ORDERS | | |

| | | |
|--|----|--|
| 1. ORIGINAL CONTRACT PRICE | \$ | |
| 2. Net change by Change Orders | \$ | |
| 3. CURRENT CONTRACT PRICE (Line 1 ± 2)..... | \$ | |
| 4. TOTAL COMPLETED AND STORED TO DATE (Column F on Progress Estimate) | \$ | |
| 5. RETAINAGE: | | |
| a. <u>10%</u> x \$ _____ Work Completed | \$ | |
| b. <u>10%</u> x \$ _____ Stored Material..... | \$ | |
| c. Total Retainage (Line 5a + Line 5b) | \$ | |
| 6. AMOUNT ELIGIBLE TO DATE (Line 4 - Line 5c)..... | \$ | |
| 7. LESS PREVIOUS PAYMENTS (Line 6 from prior Application)..... | \$ | |
| 8. AMOUNT DUE THIS APPLICATION | \$ | |
| 9. BALANCE TO FINISH, PLUS RETAINAGE (Column G on Progress Estimate + Line 5 above) | \$ | |

CONTRACTOR'S CERTIFICATION

The undersigned Contractor certifies that: (1) all previous progress payments received from Owner on account of Work done under the Contract have been applied on account to discharge Contractor's legitimate obligations incurred in connection with Work covered by prior Applications for Payment; (2) title of all Work, materials and equipment incorporated in said Work or otherwise listed in or covered by this Application for Payment will pass to Owner at time of payment free and clear of all Liens, security interests and encumbrances (except such as are covered by a Bond acceptable to Owner Indemnifying Owner against any such Liens, security interest or encumbrances); and (3) all Work covered by this Application for Payment is in accordance with the Contract Documents and is not defective.

Payment of: \$ _____
(Line 8 or other - attach explanation of another amount)

is recommended by: _____ (Date)
Doug Clark, Glick Boehm Arch., Construction Coordinator

Payment of: \$ _____
(Line 8 or other - attach explanation of another amount)

is approved by: _____ (Date)
John T. Stieglitz III, Capital Projects Director

| | |
|---|---------------------|
| For (contract): CC-38 Harrelson Building - Technology Dept. Improvements Project | Application Number: |
|---|---------------------|

| | |
|---------------------|-------------------|
| Application Period: | Application Date: |
|---------------------|-------------------|

| A | | B | Work Completed | | E | F | | G |
|---------------------------|-------------|-----------------|-----------------------------------|-------------|--|--|---------|---------------------------|
| Item | | Scheduled Value | C | D | Materials Presently Stored (not in C or D) | Total Completed and Stored to Date (C + D + E) | % (E) B | Balance to Finish (B - F) |
| Specification Section No. | Description | | From Previous Application (C + D) | This Period | | | | |
| | | | | | | | | |
| | Totals | | | | | | | |

Progress Estimate

Contractor's Application

| | | | | | | | | | | | |
|--|-------------|--------------|------------|-----------|------------------------------|-------|---------------------------------------|--|---------|---------------------------|-----------|
| For (contract): CC-38 Harrelson Building - Technology Dept. Improvements Project | | | | | | | Application Number: | | | | |
| Application Period: | | | | | | | Application Date: | | | | |
| A | | | | B | C | D | E | F | | G | H |
| Item | | Bid Quantity | Unit Price | Bid Value | Estimated Quantity Installed | Value | Materials Presently Stored (not in C) | Total Completed and Stored to Date (D + E) | % (E) B | Balance to Finish (B - F) | Retainage |
| Bid Item No. | Description | | | | | | | | | | |
| Totals | | | | | | | | | | | |

Stored Material Summary

Contractor's Application

| For contract: CC-38 Harrelson Building - Technology Dept. Improvements Project | | | | | | | Application Number: | | |
|--|------------------------------|-----------------------|-------------------|-------------|-------------------|-------------------|----------------------|-------------|---|
| Application Period: | | | | | | Application Date: | | | |
| A | B | C | D | | E | | F | | G |
| Invoice No. | Shop Drawing Transmittal No. | Materials Description | Stored Previously | | Stored this Month | | Incorporated in Work | | Materials Remaining in Storage (\$) (D + E - F) |
| | | | Date (Month/Year) | Amount (\$) | Amount (\$) | Subtotal | Date (Month/Year) | Amount (\$) | |
| | | | | | | | | | |
| | | Totals | | | | | | | |

CONTRACTOR/SUBCONTRACTOR QUALIFICATIONS

PART 1 - GENERAL

1.01 The following information and completed forms may be requested by the Owner of the three (3) lowest bidders. The request will be made the day of the Bid Opening or within five (5) days following the Bid Opening. If requested, this data must be submitted to the Construction Coordinator or the Owner within five (5) days of the request. Failure to provide the data in this section, upon request, will subject bidder to disqualification.

1.02 DESCRIPTION

- A. Information provided will be used by the Construction Coordinator or the Owner to determine the competency and ability of the Contractor and/or Subcontractor to perform the scheduled work in a manner that is satisfactory to the Construction Coordinator or the Owner. The Construction Coordinator or the Owner's decision shall be final.
- B. Any Subcontractor being used by the General Contractor, whose portion of the project exceeds 5% of the total bid price amount, will be required to provide the same information as the General Contractor.
- C. The Contractor and Subcontractor shall include with this section a detailed financial statement indicating the Contractor's or Subcontractor's financial resources. The information on that statement shall be certified by a Certified Public Accountant and shall be submitted on the Associated General Contractors of America form "Standard Questionnaires and Financial Statement for Bidders".
- D. The Contractor and Subcontractor shall certify by attaching his signature to this Section as provided that all information contained herein is complete and all statements and answers are accurate and true. Providing misinformation, incomplete information, inaccurate information, or failure to certify the information, will subject bidder to disqualification.

1.03 QUALIFICATIONS

A. Complete the following for General Contractor and any Subcontractors (attach additional sheets as required):

- 1. Name: _____
- 2. Address: _____
- 3. City, State, Zip: _____
- 4. Principle: _____

B. Number of years the company has been in business: _____

C. List and describe at least five (5) projects that have been completed, that are similar in size and type, and that has been completed within the last ten (10) years:

- 1. _____

- 2. _____

3. _____

4. _____

5. _____

D. For the projects listed above provide the following:

1. Project Owner: _____
 Contact Name and Title: _____
 Telephone Number: _____
2. Project Owner: _____
 Contact Name and Title: _____
 Telephone Number: _____
3. Project Owner: _____
 Contact Name and Title: _____
 Telephone Number: _____
4. Project Owner: _____
 Contact Name and Title: _____
 Telephone Number: _____
5. Project Owner: _____
 Contact Name and Title: _____
 Telephone Number: _____

E. For each of the projects listed in Items C & D provide the following:

1. Original Bid Amount: _____
 Final Construction Cost: _____
 Contract Period: _____
 Actual Contract Period: _____
 Explanation: _____
2. Original Bid Amount: _____
 Final Construction Cost: _____
 Contract Period: _____
 Actual Contract Period: _____
 Explanation: _____

3. Original Bid Amount: _____
 Final Construction Cost: _____
 Contract Period: _____
 Actual Contract Period: _____
 Explanation: _____
4. Original Bid Amount: _____
 Final Construction Cost: _____
 Contract Period: _____
 Actual Contract Period: _____
 Explanation: _____
5. Original Bid Amount: _____
 Final Construction Cost: _____
 Contract Period: _____
 Actual Contract Period: _____
 Explanation: _____

F. Provide the following for any portion of the work that is being subcontracted (5% or more of the Bid Amount):

1. Name of Subcontractor: _____
 Address City/State/Zip: _____
 Telephone Number: _____
 Work being completed: _____
2. Name of Subcontractor: _____
 Address City/State/Zip: _____
 Telephone Number: _____
 Work being completed: _____
3. Name of Subcontractor: _____
 Address City/State/Zip: _____
 Telephone Number: _____
 Work being completed: _____
4. Name of Subcontractor: _____
 Address City/State/Zip: _____
 Telephone Number: _____
 Work being completed: _____
5. Name of Subcontractor: _____
 Address City/State/Zip: _____
 Telephone Number: _____
 Work being completed: _____

G. Provide a list of equipment that is owned by the Contractor and is available for this project.

H. Provide a list of equipment that will be purchased, leased or rented for this project.

I. Provide a list of the superintendent(s) or others that will be in charge of this project (Provide resumes and qualifications):

J. Provide the following for current projects being completed:

1. Project Name: _____
Owner: _____
Current Status: _____
Estimated Schedule of Completion: _____

2. Project Name: _____
Owner: _____
Current Status: _____
Estimated Schedule of Completion: _____

3. Project Name: _____
Owner: _____
Current Status: _____
Estimated Schedule of Completion: _____

4. Project Name: _____
Owner: _____
Current Status: _____
Estimated Schedule of Completion: _____

5. Project Name: _____
Owner: _____
Current Status: _____
Estimated Schedule of Completion: _____

K. Provide a list of the last five (5) projects that has been completed with the Owner over the past fifteen (15) years:

1. Project Name: _____
Contact Name and Title: _____
Telephone Number: _____

2. Project Name: _____
Contact Name and Title: _____
Telephone Number: _____

3. Project Name: _____
Contact Name and Title: _____
Telephone Number: _____

4. Project Name: _____
Contact Name and Title: _____
Telephone Number: _____

5. Project Name: _____
Contact Name and Title: _____
Telephone Number: _____

L. Provide a list of last five (5) projects that Bid with the Owner over the past fifteen (15) years:

1. Project Name: _____
Contact Name and Title: _____
Telephone Number: _____

2. Project Name: _____
Contact Name and Title: _____
Telephone Number: _____

3. Project Name: _____
Contact Name and Title: _____
Telephone Number: _____

4. Project Name: _____
Contact Name and Title: _____
Telephone Number: _____

5. Project Name: _____
Contact Name and Title: _____
Telephone Number: _____

M. Provide a list of projects completed with the Construction Coordinator over the past fifteen (15) years:

1. Project Name: _____
Project Engineer: _____
Original Bid Amount: _____
Final Construction Cost: _____
Contract Period: _____
Actual Contract Period: _____
Explanation: _____

2. Project Name: _____
Project Engineer: _____
Original Bid Amount: _____
Final Construction Cost: _____
Contract Period: _____
Actual Contract Period: _____
Explanation: _____

3. Project Name: _____
Project Engineer: _____
Original Bid Amount: _____
Final Construction Cost: _____
Contract Period: _____
Actual Contract Period: _____
Explanation: _____

4. Project Name: _____
Project Engineer: _____
Original Bid Amount: _____
Final Construction Cost: _____
Contract Period: _____
Actual Contract Period: _____
Explanation: _____

5. Project Name: _____
Project Engineer: _____
Original Bid Amount: _____
Final Construction Cost: _____
Contract Period: _____
Actual Contract Period: _____
Explanation: _____

N. Provide a list of projects involved with litigation, arbitration and/or mediation over the past twenty (20) years:

1. Project Name: _____
Project Owner: _____
Project Engineer: _____
Date: _____
Explanation: _____

2. Project Name: _____
Project Owner: _____
Project Engineer: _____
Date: _____
Explanation: _____

3. Project Name: _____
Project Owner: _____
Project Engineer: _____
Date: _____
Explanation: _____

4. Project Name: _____
Project Owner: _____
Project Engineer: _____
Date: _____
Explanation: _____

5. Project Name: _____
Project Owner: _____
Project Engineer: _____
Date: _____
Explanation: _____

O. Attach a rate schedule associated with equipment that includes labor, overhead and profit.

_____ Rate Schedule Attached.

P. Additional information if necessary.

I HEREBY CERTIFY that as a duly authorized representative of _____ (Bidder), the information provided is to the best of my knowledge accurate and that failure to provide accurate information will result in disqualification of my bid.

Signature

Name (Please Print)

Title

Date

Notary Public for South Carolina

My Commission Expires: _____

Unit Prices – CC-38 Harrelson Building – Technology Dept Imps Project. Bidder to apply quantities to each description

| <i>Item</i> | <i>Description</i> | <i>Unit</i> | <i>Quantity</i> | <i>Unit Price</i> | <i>Bid Price</i> |
|--|---------------------------------------|-------------|-----------------|-------------------|----------------------|
| General | | | | | |
| | Mobilization | LS | 1 | \$ | \$ |
| | Bonds | % | 1 | \$ | \$ |
| | Insurance | LS | 1 | \$ | \$ |
| | Permitting | LS | 1 | \$ | \$ |
| | Utilities | LS | 1 | \$ | \$ |
| | Rental Equipment | LS | 1 | \$ | \$ |
| | Site Superintendent/Supervision | HR | 1 | \$ | \$ |
| | Overhead and Profit | % | 1 | \$ | \$ |
| | Temporary Facility Rental and Set Up | LS | 1 | \$ | \$ |
| | Temporary Power | LS | 1 | \$ | \$ |
| | Warranties | LS | 1 | \$ | \$ |
| Demolition-General Cost | | | | | |
| | Temporary partitions | SF | 1 | \$ | \$ |
| | Barricades / signs | LS | 1 | \$ | \$ |
| | Haul and dump | CY | | \$ | \$ |
| | Dump charges | CY | | \$ | \$ |
| Architecture | | | | | |
| | Framing | SF | | \$ | \$ |
| | Wooden finishes | LF | | \$ | \$ |
| | Reception Counter | LS | | \$ | \$ |
| | Hourly Rate | HR | 1 | \$ | XXXXXXXXXXXXXXXXXXXX |
| Doors and Windows | | | | | |
| | Wood Interior Doors, Complete | EA | | \$ | \$ |
| Door Hardware Includes installation | | | | | |
| | Hardware Set 0 | LS | | \$ | \$ |
| | Hourly Rate | HR | 1 | | XXXXXXXXXXXXXXXXXXXX |
| Finishes | | | | | |
| | Paint Flat Surface | SF | | \$ | \$ |
| | Paint Doors | SF | | \$ | \$ |
| | Paint Exterior | LS | | \$ | \$ |
| | LVT Flooring | SF | | \$ | \$ |
| | Carpet | SF | | \$ | \$ |
| | Ceiling tiles and track | SF | | \$ | \$ |
| | Hourly Rate | HR | 1 | \$ | XXXXXXXXXXXXXXXXXXXX |
| Specialties | | | | | |
| | Fire Extinguisher w/cabinet, complete | EA | | \$ | \$ |
| | Door Access System | LS | | \$ | \$ |
| | Hourly Rate | HR | 1 | \$ | XXXXXXXXXXXXXXXXXXXX |
| HVAC | | | | | |
| | HVAC Complete | LS | 1 | \$ | \$ |
| | Hourly Rate | HR | 1 | \$ | XXXXXXXXXXXXXXXXXXXX |
| Electrical | | | | | |
| | Empty Raceway System | LS | | \$ | \$ |
| | Outlet Empty | EA | | \$ | \$ |
| | 3/4" EMT | LF | | \$ | \$ |

| | | | | | |
|--|---|----|---|---------------|------------------------|
| | Pull String | LF | | \$ | \$ |
| | 3" PVC | LF | | \$ | \$ |
| | Pull String | LF | | \$ | \$ |
| | Telephone/Data Outlet Empty | EA | | \$ | \$ |
| | Fire Alarm System | LS | | \$ | \$ |
| | Hourly Rate | HR | 1 | \$ | XXXXXXXXXXXXXXXXXXXXXX |
| | Owners Allowances at Owners Discretion | | | | |
| | Unfounded issues | LS | 1 | \$50,000.00 | \$50,000.00 |
| | <i>* Total should match the bid price*</i> | | | Total: | \$ |



CC-38 BID SUBMITTAL

**Bids are to be submitted via email to:
Kaye B. Syfrett, Procurement Manager at ksyfrett@colletoncounty.org**

=====

Contractor: _____

Address: _____

City: _____ State: _____ Zip: _____

Telephone Number: () _____

Contact Person & Title: _____

Email Address: _____

Federal Tax ID number: _____

Contractor's license number: _____

REFERENCES

The contractor must list a minimum of three (3) references along with pictures of the completed work.

| | |
|---------------------------|-------------------------------------|
| <u>Reference 1</u> | |
| Name of Business: _____ | |
| Address: _____ | City: _____ State: _____ Zip: _____ |
| Contact: _____ | Title: _____ Telephone #: _____ |
| Email Address: _____ | |
| Services provided: _____ | Years of Service: _____ |

THIS PAGE MUST BE COMPLETED AND SUBMITTED AS A PART OF YOUR BID

Reference 2

Name of Business: _____

Address: _____ City: _____ State: ____ Zip: _____

Contact: _____ Title: _____ Telephone #: _____

Email Address: _____

Services provided: _____ Years of Service: _____

Reference 3

Name of Business: _____

Address: _____ City: _____ State: ____ Zip: _____

Contact: _____ Title: _____ Telephone #: _____

Email Address: _____

Services provided: _____ Years of Service: _____

ADDENDA ACKNOWLEDGMENT

The contractor has examined and carefully studied the Request for Bid and the following Addenda, receipt of all of which is hereby acknowledged:

| <i>Amendment No.</i> | <i>Issue Date</i> |
|-----------------------------|--------------------------|
| | |
| | |
| | |
| | |

By signing the Bid Submittal Form the Contractor(s) acknowledges any and all issued addenda. Bids which fail to acknowledge the contractor's receipt of any addendum will result in the rejection of the offer if the addendum contained information which substantively changes the Owner's requirements or pricing.

Contractor: _____

Authorized Representative Name and Title: _____

Signature of Authorized Representative: _____

THIS PAGE MUST BE COMPLETED AND SUBMITTED AS A PART OF YOUR BID

INDEMNIFICATION

The undersigned Bidder/Proposer will indemnify and hold harmless the Owner, Colleton County and their agents and employees from and against all claims, damages, losses and expenses, including attorney's fees, arising out of or resulting from the performance of the Work provided that any such claims, damages, loss, or expense is attributable to bodily injury, sickness, disease or death, injury to or destruction of tangible property, including the loss of use resulting there from, and is caused by any negligent or willful act or omission of the Bidder/Proposer, and anyone directly or indirectly employed by him/her or anyone for whose acts any of them may be liable.

In any and all claims against the Owner, Colleton County or any of their agents and / or employees by an employee of the Bidder/Proposer, and anyone directly or indirectly employed by any of them, or anyone for whose acts any of them may be liable, the indemnification obligation shall not be limited in any way to the amount or type of damages, compensation or benefits payable by or for the Bidder / Proposer under the Worker's Compensation Acts, Disability Benefit Acts, or other employee benefit acts.

The obligation of the Bidder/Proposer under this paragraph shall not extend to the liability of Colleton County or its agents and/or employees arising out of the reports, surveys, Change Orders, designs or Technical Specifications.

CERTIFICATE OF FAMILIARITY

The undersigned, having fully familiarized him/her with the information contained within this entire solicitation and applicable amendments, submits the attached response, and other applicable information to the County, which I verify to be true and correct to the best of my knowledge. I further certify that this response is made without prior understanding, agreement, or connection with any corporation, contractor, or person submitting a response for the same materials, supplies or equipment, and is in all respects, fair and without collusion or fraud. I agree to abide by all conditions outlined in this solicitation and certify that I have signature authority to bind the company listed herein.

Are you a minority business?

▶ **Yes** _____ (_____ *Women-owner*/ _____ *Disadvantaged*) if yes, please submit a copy of your certificate with your response.

▶ **No** _____

Contractor: _____

Authorized Representative Name and Title: _____

Signature of Authorized Representative: _____

THIS PAGE MUST BE COMPLETED AND SUBMITTED AS A PART OF YOUR BID

DEBARMENT

The Contractor is certifying that they are not currently debarred from responding to any request for bids by any agency or subdivision of the State of South Carolina or the United States Federal Government, nor are they an agent of any person or entity that is currently debarred from submitting bids on contracts by any agency or subdivision of the State of South Carolina or the United States Federal Government.

A Registered Contractor with SAM's: Yes No

Cage Code. _____

DUN's No. _____

Contractor: _____

Authorized Representative Name and Title: _____

Signature of Authorized Representative: _____

THIS PAGE MUST BE COMPLETED AND SUBMITTED AS A PART OF YOUR BID

ACKNOWLEDGMENT OF PRINCIPAL, IF A PARTNERSHIP

State of: (_____)

County of: (_____)

On this _____ day of _____, 20____, before me personally, came and appeared _____, to me known and known to me to be the person described in and who executed the foregoing instrument and he acknowledged to me that he executed the same as and for the act and deed of said firm.

(Seal) _____
Notary Public

ACKNOWLEDGMENT OF PRINCIPAL, IF AN INDIVIDUAL

State of: (_____)

County of: (_____)

On this _____ day of _____, 20____, before me personally, came and appeared _____, to me known and known to me to be the person described in and who executed the foregoing instrument and acknowledged that he executed the same.

(Seal) _____
Notary Public

ACKNOWLEDGMENT OF PRINCIPAL, IF A CORPORATION

State of: (_____)

County of: (_____)

On this _____ day of _____, 20____, before me personally came and appeared _____ to me Known, who, being by me duly sworn, did depose and say to me that he resides at _____, that he/she is the _____ of _____, the corporation described in and which executed the foregoing instrument is an impression of such seal; that it was so affixed by the order of the directors of said corporation, and that he signed his name thereto by like order.

(Seal) _____
Notary Public

LIST OF PRIME AND SUBCONTRACTORS

The undersigned Bidder/Proposer states that the following is a full and complete list of proposed prime contractors and subcontractors on this Project and the class of work to be performed by each, and that such list will not be added to nor altered without the written consent of the Owner.

| | Class of Work to be Performed | Subcontractor |
|----|--------------------------------------|----------------------|
| 1) | Access Control | _____ |
| 2) | Electrical | _____ |
| 3) | Mechanical | _____ |
| 4) | Ceiling tiles | _____ |
| 5) | Architectural | _____ |
| 6) | Raised floor | _____ |
| 7) | Painting | _____ |
| 8) | Technology Equip. Installation | _____ |
| 9) | Glass/storefront | _____ |

Listed subcontractors must meet all qualifications including documented experience set forth in specifications, including those sections specifying single source contractor requirements.

The remainder of this page was intentionally left blank

BID BOND

Any singular reference to Bidder, Surety, Owner, or other party shall be considered plural where applicable.

BIDDER (Name and Address): _____

SURETY (Name and Address of Principal Place of Business): _____

OWNER (Name and Address): Colleton County
109 Benson Street
Walterboro, SC 29488

Bid Number: **CC-38**

Bid Due Date: **Wednesday, April 19, 2023 at 11:00am**

Project (Brief Description Including Location): **Renovation of the current Technology Dept. workspace in the Harrelson Building at 31 Klein Street, Walterboro, SC 29488. The project includes a new network workspace, office space renovation, technology support systems, applicable equipment, and 1st-floor corridor improvements.**

Bond Number: _____

Date (Not later than Bid due date): _____

Penal sum _____ (Words) _____ (Figures)

Surety and Bidder, intending to be legally bound hereby, subject to the terms printed on the reverse side hereof, do each because this Bid Bond to be duly executed on its behalf by its authorized officer, agent, or representative.

BIDDER

Bidder's Name and Corporate Seal

SURETY

(Seal) _____ (Seal)
Surety's Name and Corporate Seal

By: _____
Signature and Title

By: _____
Signature and Title
(Attach Power of Attorney)

Attest: _____
Signature and Title

Attest: _____
Signature and Title

1. Bidder and Surety, jointly and severally, bind themselves, their heirs, executors, administrators, successors and assigns to pay to Owner upon default of Bidder the penal sum set forth on the face of this Bond. Payment of the penal sum is the extent of Surety's liability.
2. Default of Bidder shall occur upon the failure of Bidder to deliver within the time required by the Bidding Documents (or any extension thereof agreed to in writing by Owner) the executed Agreement required by the Bidding Documents and any performance and payment bonds required by the Bidding Documents.
3. This obligation shall be null and void if:
 - 3.1. Owner accepts Bidder's Bid and Bidder delivers within the time required by the Bidding Documents (or any extension thereof agreed to in writing by Owner) the executed Agreement required by the Bidding Documents and any performance and payment bonds required by the Bidding Documents, or
 - 3.2. All Bids are rejected by Owner, or
 - 3.3. Owner fails to issue a Notice of Award to Bidder within the time specified in the Bidding Documents (or any extension thereof agreed to in writing by Bidder and, if applicable, consented to by Surety when required by Paragraph 5 hereof).
4. Payment under this Bond will be due and payable upon default by Bidder and within 30 calendar days after receipt by Bidder and Surety of written notice of default from Owner, which notice will be given with reasonable promptness, identifying this Bond and the Project and including a statement of the amount due.
5. Surety waives notice of any and all defenses based on or arising out of any time extension to issue Notice of Award agreed to in writing by Owner and Bidder, provided that the total time for issuing Notice of Award including extensions shall not in the aggregate exceed 120 days from Bid due date without Surety's written consent.
6. No suit or action shall be commenced under this Bond prior to 30 calendar days after the notice of default required in Paragraph 4 above is received by Bidder and Surety and in no case later than one year after Bid due date.
7. Any suit or action under this Bond shall be commenced only in a court of competent jurisdiction located in the state in which the Project is located.
8. Notices required hereunder shall be in writing and sent to Bidder and Surety at their respective addresses shown on the face of this Bond. Such notices may be sent by personal delivery, commercial courier, or by United States Registered or Certified Mail, return receipt requested, postage pre-paid, and shall be deemed to be effective upon receipt by the party concerned.
9. Surety shall cause to be attached to this Bond a current and effective Power of Attorney evidencing the authority of the officer, agent, or representative who executed this Bond on behalf of Surety to execute, seal, and deliver such Bond and bind the Surety thereby.
10. This Bond is intended to conform to all applicable statutory requirements. Any applicable requirement of any applicable statute that has been omitted from this Bond shall be deemed to be included herein as if set forth at length. If any provision of this Bond conflicts with any applicable statute, then the provision of said statute shall govern and the remainder of this Bond that is not in conflict therewith shall continue in full force and effect.
11. The term "Bid" as used herein includes a Bid, offer, or proposal as applicable.

1 - BIDDER'S ACKNOWLEDGEMENTS

- 1.01 The undersigned Bidder/Proposer, proposes and agrees, if this Bid is accepted, to enter into an Agreement/Contract with the Owner as stated in the form included in the Bidding Documents to perform all Work as specified or indicated in the Bidding Documents for the prices and within the times indicated in this Bid and in accordance with the other terms and conditions of the Bidding Documents.
- 1.02 The undersigned Bidder/Proposer, having fully familiarized him/her with the information contained within this entire solicitation and applicable amendments, submits the attached response, and other applicable information to the County, which I verify to be true and correct to the best of my knowledge. I further certify that this response is made without prior understanding, agreement, or connection with any corporation, Offeror or person submitting a response for the same materials, supplies or equipment, and is in all respects, fair and without collusion or fraud. I agree to abide by all conditions set forth in this solicitation and certify that I have signature authority to bind the company listed herein.
- 1.03 Bidder accepts all of the terms and conditions of the Instructions to Bidders, including without limitation those dealing with the disposition of Bid security. This Bid will remain subject to acceptance for **ninety (90) days** after the Bid opening, or for such longer period of time that Bidder may agree to in writing upon request of the Owner.
- 1.04 For additional work authorized after signing the Contract, the amount of overhead and the amount of profit to be added to base costs of labor and materials as noted in the unit price sheet shall be (10%) total for overhead and profit on work performed by the General Contractor's own forces and (15%) total on work by Subcontractors. Request of additional charges for site supervision, utilities, rentals, or administrative services will not be approved unless the additional requested work warrants adding additional days to the contract term. All request for additional work authorization shall have as an attachment, an **itemized breakdown** of the subcontractor and/or General Contractors work to be performed to include the actual quote for supplies from the general contractor or sub-contractor's suppliers. The General Contractor and sub-contractors itemized list shall have the Labor Hours, Rates, Overhead and Profit itemized. The Sub-contractor shall list as an itemized unit cost any additional labor to include the labor hours and rates associated with the requested work. The itemized list shall be shown on the subcontractor or General Contractors letter head and signed by the head officer or the owner of the said company.
- 1.05 Bidder acknowledges the requirements of the Performance Bonds and Payment Bonds.

2 - BIDDER'S REPRESENTATIONS

- 2.01 In submitting this Bid, Bidder represents that:
- A. Bidder has examined and carefully studied the Bidding Documents, the other related data identified in the Bidding Documents, and the any issued Addenda, which is hereby acknowledged with the attached Addendum form.
 - B. Bidder has visited the Site and become familiar with and is satisfied as to the general, local and Site conditions that may affect cost, progress, and performance of the Work.
 - C. Bidder is familiar with and is satisfied as to all federal, state and local Laws and Regulations that may affect cost, progress and performance of the Work.

- D. Bidder has carefully studied all: (1) reports of explorations and tests of subsurface conditions at or contiguous to the Site and all drawings of physical conditions in or relating to existing surface or subsurface structures at or contiguous to the Site (except Underground Facilities), which have been identified in Paragraph 4.02 of General Conditions, and (2) reports and drawings of Hazardous Environmental Conditions that have been identified in Paragraph 4.06 of General Conditions.
- E. Bidder has obtained and carefully studied (or accepts the consequences for not doing so) all additional or supplementary examinations, investigations, explorations, tests, studies and data concerning conditions (surface, subsurface and Underground Facilities) at or contiguous to the Site, which may affect cost, progress, or performance of the Work or which relate to any aspect of the means, methods, techniques, sequences, and procedures of construction to be employed by Bidder, including applying the specific
- F. Means, methods, techniques, sequences, and procedures of construction expressly required by the Bidding Documents to be employed by Bidder, and safety precautions and programs incident thereto.
- G. Bidder does not consider that any further examinations, investigations, explorations, tests, studies, or data are necessary for the determination of this Bid for performance of the Work at the price(s) bid and within the times and in accordance with the other terms and conditions of the Bidding Documents.
- H. Bidder is aware of the general nature of work to be performed by the Owner and others at the Site that relates to the Work as indicated in the Bidding Documents.
- I. Bidder has correlated the information known to Bidder, information and observations obtained from visits to the Site, reports and drawings identified in the Bidding Documents, and all additional examinations, investigations, explorations, tests, studies, and data with the Bidding Documents.
- J. Bidder has given the Owner written notice of all conflicts, errors, ambiguities, or discrepancies that Bidder has discovered in the Bidding Documents, and the written resolution thereof by the Owner is acceptable to Bidder.
- K. The Bidding Documents are generally sufficient to indicate and convey understanding of all terms and conditions for the performance of the Work for which this Bid is submitted.
- L. Bidder will submit written evidence of its authority to do business in the state where the Project is located not later than the date of its execution of the Agreement.

3 - FURTHER REPRESENTATIONS

3.01 Bidder further represents that:

- A. This Bid is genuine and not made in the interest of or on behalf of any undisclosed individual or entity and is not submitted in conformity with any agreement or rules of any group, association, organization, or corporation.
- B. Bidder has not directly or indirectly induced or solicited any other Bidder to submit a false or sham Bid.
- C. Bidder has not solicited or induced any individual or entity to refrain from bidding.

- D. The bidder affirms that in making such a Bid, neither he/she nor any company may represent, nor anyone on behalf of him/her or their company, directly or indirectly, has entered into any combination, collusion, undertaking, or agreement with any other Bidder or Bidders to maintain the prices of said work, or any compact to prevent any other Bidder or Bidders from Bidding on said Contract or work and further affirms that such bid is made without regard or reference to any other Bidder or Proposer and without any agreement or understanding or combination either directly or indirectly with any other person or persons with reference to such Bidding in any way or manner whatsoever.

- E. Any attempt by the vendor to influence the opinion of Colleton County Staff or Colleton County Council by discussion, promotion, advertising, or misrepresentation of the submittal or purchasing process or any procedure to promote their offer will constitute a violation of the vendor submittal conditions and will cause the vendor's submittal to be declared null and void.

4 - TIME OF COMPLETION

- 4.01 **Renovation of the current Technology Dept. workspace in the Harrelson Building at 31 Klein Street, Walterboro, SC 29488. The project includes a new network workspace, office space renovation, technology support systems, applicable equipment, and 1st-floor corridor improvements to be completed within Two Hundred Seventy (270) calendar days after the "Notice to Proceed" has been issued.**

- 4.02 Bidder accepts the provisions of the Agreement as to liquidate damages, in the event of failure to complete the Work within the Contract dates in the amount of \$500 per day for each calendar day required to complete the work in the manner and within the dates as stated in Paragraph 4.01 above.

5 - BID SUBMITTAL

5.01 This Bid submitted by:

An Individual

Name (typed or printed): _____

By: _____ (SEAL) Title: _____
(Individual's signature)

Doing business as: _____

A Partnership

Partnership Name: _____

By: _____ (SEAL) Title: _____
(Signature of general partner -attach evidence of authority to sign)

Name (typed or printed): _____

A Corporation

Corporation Name: _____ (SEAL)

State of Incorporation: _____ Type (General Business, Professional, Service, Limited Liability): _____

By: _____

(Signature -- attach evidence of authority to sign)

Name (typed or printed): _____

Title: _____ (CORPORATE SEAL)

Attest _____

Date of Authorization to do business in [South Carolina] is ____/____/____.

A Joint Venture

Name of Joint Venture: _____

First Joint Ventures Name: _____ (SEAL)

By: _____

(Signature of first joint venture partner -- attach evidence of authority to sign)

Name (typed or printed): _____

Title: _____

Second Joint Ventures Name: _____ (SEAL)

By: _____

(Signature of second joint venture partner -- attach evidence of authority to sign)

Name (typed or printed): _____

Title: _____

(Each joint venture must sign. The manner of signing for each individual, partnership, and corporation that is a party to the joint venture should be in the manner indicated above.)

Bidder's Business Address _____

Telephone No.: _____ Fax No.: _____

SUBMITTED on _____, 2023.

State Contractor License No. _____

6 – BASIS OF BID

BASE BID & ALTERNATE BID LS PRICES

Base Bid price and Alternate Bid Prices shall be for the Work as specified, and shall include all labor, supervision, administrative support, materials, equipment, accessories, shipping, preparation, insurance, testing, overhead, profit, applicable taxes, permits, fees, supervision, warranties and all other associated costs for the finished and completed Work. Bid shall include the prices for undercut soils shall include material in place, surveyed and compacted pursuant to the Contract Documents.

Contractor shall make quantity take-offs using drawings and specifications to determine quantities to his satisfaction, reporting promptly any discrepancies which may affect bidding.

The Owner shall have the right to accept Alternates in any order or combination, and to determine the low bidder on the basis of the sum of the Base Bid and Alternates accepted.

- a. Bidder will complete the Work in accordance with the Contract Documents and the following Allowances are established for this project.

| | | | |
|---|----|---|--------------|
| <u>Owner's Allowance - CC-38 Renovation of the current Technology Dept. workspace in the Harrelson Building at 31 Klein Street, Walterboro, SC 29488. The project includes a new network workspace, office space renovation, technology support systems, applicable equipment, and 1st-floor corridor improvements to be completed within Two Hundred Seventy (270) calendar days after the "Notice to Proceed" has been issued.</u> | | | |
| Unfounded issues | LS | 1 | \$ 50,000.00 |

7 - BASE BID ALTERNATES

7.01 **No Alternates**

The remainder of this page was intentionally left blank

8 - Base Bid

8.01 BID BREAKDOWN **This section must be completed.** Bid breakdown total should match the bid proposal. **Failure to complete the bid breakdown will result in the submitted bid being disqualified.**

| | | | |
|---|----|-------|--------------|
| Unfounded issues Allowance | LS | 1 | \$ 50,000.00 |
| Technology Renovation and Improvements Complete | LS | 1 | \$ |
| | | Total | \$ |

8.02 BASE BID PROPOSAL: The Bidder agrees to perform all of the work described in the solicitation document CC-38 to include the Specifications, General Conditions, including allowances, and items shown on the drawings, as totaled in 8.01 for the sum of:

_____ \$ _____
(Amount in words) (Numerical)

Company Name: _____

Contact Person: _____

Address: _____

City/State/Zip: _____

Phone Number: _____

Cell Phone Number: _____

E-mail Address: _____
(Please print)

Signature: _____

End of Base Bid

TABLE OF CONTENTS

(2 OF 2)

DIVISION 001 – GENERAL CONDITIONS

| | |
|--|-----------|
| PART 1 - DEFINITIONS AND TERMINOLOGY | 4 |
| 1.01 Defined Terms | 4 |
| 1.02 Terminology | 7 |
| PART 2 - PRELIMINARY MATTERS | 9 |
| 2.01 Delivery of Bonds and Evidence of Insurance | 9 |
| 2.02 Copies of Documents | 9 |
| 2.03 Commencement of contract times; Notice to Proceed | 9 |
| 2.04 Starting the Work | 9 |
| 2.05 Before Starting Construction | 9 |
| 2.06 Preconstruction Conference | 9 |
| 2.07 Initial Acceptance of Schedules | 10 |
| PART 3 - CONTRACT DOCUMENTS: INTENT, AMENDING, REUSE..... | 10 |
| 3.01 Intent | 10 |
| 3.02 Referenced Standards | 10 |
| 3.03 Reporting and Resolving Discrepancies | 11 |
| 3.04 Amending and Supplementing Contract Documents | 11 |
| 3.05 Reuse of Documents | 12 |
| 3.06 Electronic Data | 12 |
| PART 4 - AVAILABILITY OF LANDS; SUBSURFACE AND PHYSICAL CONDITIONS; | |
| HAZARDOUS ENVIRONMENTAL CONDITIONS; REFERENCE POINTS | 12 |
| 4.01 Availability of Lands | 12 |
| 4.02 Subsurface and Physical Conditions | 13 |
| 4.03 Differing Subsurface of Physical Conditions | 13 |
| 4.04 Underground Facilities | 14 |
| 4.05 Reference Points | 15 |
| 4.06 Hazardous Environmental Conditions at Site | 15 |
| PART 5- BONDS AND INSURANCE | 15 |
| 5.01 Performance, Payment, and Other Bonds | 15 |
| 5.02 Licensed Sureties and Insurers | 16 |
| 5.03 Certificates of Insurance | 16 |
| 5.04 Contractor’s Liability Insurance | 16 |
| 5.05 Owner’s Liability Insurance | 19 |
| 5.06 Property Insurance | 19 |
| 5.07 Waiver of Rights | 20 |
| 5.08 Receipt and Application of Insurance Proceeds | 20 |
| 5.09 Acceptance of Bonds and Insurance, Options to Replace | 21 |
| 5.10 Partial Utilization, Acknowledgement of Property Insurer | 21 |
| PART 6 - CONTRACTOR’S RESPONSIBILITIES | 21 |
| 6.01 Supervision and Superintendence | 21 |
| 6.02 Labor; Working Hours | 22 |
| 6.03 Services, Materials, and Equipment | 22 |
| 6.04 Progress Schedule | 22 |
| 6.05 Substitutes and “Or-Equals” | 22 |
| 6.06 Concerning Subcontractors, Suppliers, and Others | 25 |
| 6.07 Patent Free and Royalties | 26 |
| 6.08 Permits | 26 |
| 6.09 Laws and Regulations | 26 |

| | | |
|--|---|-----------|
| 6.10 | Taxes | 27 |
| 6.11 | Use of Site and Other Areas | 27 |
| 6.12 | Record Documents | 27 |
| 6.13 | Safety Protection | 28 |
| 6.14 | Safety Representative | 28 |
| 6.15 | Hazard Communication Program | 28 |
| 6.16 | Emergencies | 29 |
| 6.17 | Shop Drawings and Samples | 29 |
| 6.18 | Continuing the Work | 31 |
| 6.19 | Contractor's General Warranty and Guarantee | 31 |
| 6.20 | Indemnification | 32 |
| 6.21 | Delegation of Professional Design Services | 32 |
| PART 7 - OTHER WORK AT THE SITE..... | | 33 |
| 7.01 | Related Work at Site | 33 |
| 7.02 | Coordination | 33 |
| 7.03 | Legal Relationships | 34 |
| 7.04 | Claims between Contractors | 34 |
| PART 8 - OWNER'S RESPONSIBILITIES..... | | 34 |
| 8.01 | Communications to Contractor | 34 |
| 8.02 | Replacement of Construction Coordinator | 35 |
| 8.03 | Furnish Data | 35 |
| 8.04 | Pay When Due | 35 |
| 8.05 | Lands and Easements; Reports and Test | 35 |
| 8.06 | Insurance | 35 |
| 8.07 | Change Orders | 35 |
| 8.08 | Inspections, Test, and Approvals | 35 |
| 8.09 | Limitations on Owner's Responsibilities | 35 |
| 8.10 | Undisclosed Hazardous Environmental Conditions | 35 |
| 8.11 | Evidence of Financial Arrangements | 35 |
| PART 9 - CONSTRUCTION COORDINATOR'S STATUS DURING CONSTRUCTION | | 36 |
| 9.01 | Owner's Representative | 36 |
| 9.02 | Visits to Site | 36 |
| 9.03 | Project Representative | 36 |
| 9.04 | Authorized Variations in Work | 36 |
| 9.05 | Rejecting Defective Work | 37 |
| 9.06 | Shop Drawings, Change Orders and Payments | 37 |
| 9.07 | Determinations for Unit Price Work | 37 |
| 9.08 | Decisions on Requirements of Contract Documents and Acceptability of Work | 37 |
| 9.09 | Limitations on Construction Coordinators Authority and Responsibility | 38 |
| PART 10 - CHANGES IN THE WORK; CLAIMS..... | | 38 |
| 10.01 | Authorized Changes in Work | 38 |
| 10.02 | Unauthorized Changes in Work | 38 |
| 10.03 | Execution of Change Orders | 39 |
| 10.04 | Notification of Surety | 39 |
| 10.05 | Claims | 39 |
| PART 11 - COST OF THE WORK; ALLOWANCES; UNIT PRICE WORK..... | | 40 |
| 11.01 | Cost of the Work | 40 |
| 11.02 | Allowances | 42 |
| 11.03 | Unit Price Work | 43 |
| PART 12 - CHANGE OF CONTRACT PRICE; CHANGE OF CONTRACT TIMES..... | | 43 |
| 12.01 | Change of Contract Price | 43 |
| 12.02 | Change of Contract Times | 44 |
| 12.03 | Delays | 44 |
| PART 13 - TESTS AND INSPECTIONS; CORRECTION, REMOVAL OR ACCEPTANCE OF | | |

| | |
|--|-----------|
| DEFECTIVE WORK | 45 |
| 13.01 Notice of Defects | 45 |
| 13.02 Access to Work | 45 |
| 13.03 Test and Inspections | 45 |
| 13.04 Uncovering Work | 46 |
| 13.05 Owner May Stop the Work | 46 |
| 13.06 Correction or Removal of Defective Work | 47 |
| 13.07 Correction Period | 47 |
| 13.08 Acceptance of Defective Work | 48 |
| 13.09 Owner may Correct Defective Work | 48 |
| | |
| PART 14 - PAYMENTS TO CONTRACTOR AND COMPLETION | 49 |
| 14.01 Schedule of Values | 49 |
| 14.02 Progress Payment | 49 |
| 14.03 Contractor's Warranty of Title | 51 |
| 14.04 Substantial Completion | 51 |
| 14.05 Partial Utilization | 52 |
| 14.06 Final Inspection | 53 |
| 14.07 Final Payment | 53 |
| 14.08 Final Completion Delayed | 54 |
| 14.09 Waiver of Claims | 54 |
| | |
| PART 15 - SUSPENSION OF WORK AND TERMINATION | 54 |
| 15.01 Owner May Suspend Work | 54 |
| 15.02 Owner May Terminate for Cause | 55 |
| 15.03 Owner May Terminate for Convenience | 56 |
| 15.04 Contractor May stop Work or Terminate | 56 |
| | |
| PART 16 - DISPUTE RESOLUTION..... | 56 |
| 16.01 Methods and Procedures | 56 |
| | |
| PART 17 - MISCELLANEOUS | 57 |
| 17.01 Giving Notice | 57 |
| 17.02 Access to Work | 57 |
| 17.03 Test and Inspections | 57 |
| 17.04 Uncovering Work | 57 |
| 17.05 Owner May Stop the Work | 57 |
| 17.06 Computation of Times | 57 |

END OF SECTION

DIVISION 001 – GENERAL CONDITIONS

STANDARD GENERAL CONDITIONS OF THE CONSTRUCTION CONTRACT

PART 1 - DEFINITIONS AND TERMINOLOGY

1.01 Defined Terms

- A. Wherever used in the Bidding Requirements or Contract Documents and printed with initial capital letters, the terms listed below will have the meanings indicated which are applicable to both the singular and plural thereof. In addition to terms specifically defined, terms with initial capital letters in the Contract Documents include references to identified Parts and paragraphs and the titles of other documents or forms.
1. Addenda – Written or graphic instruments issued prior to the opening of Bids that clarify, correct, or change the Bidding Requirements or the proposed Contract Documents.
 2. Agreement – The written instrument which is evidence of the agreement between the Owner and Contractor covering the Work.
 3. Application for Payment – The form acceptable to the Construction Coordinator which is to be used by the Contractor during the course of the Work in requesting progress or final payments and which is to be accompanied by such supporting documentation as is required by the Contract Documents.
 4. Asbestos – Any material that contains more than one percent asbestos and is friable or is releasing asbestos fibers into the air above current action levels established by the United States Occupational Safety and Health Administration.
 5. Bid – The offer or proposal of a Bidder submitted on the prescribed form setting forth the prices for the Work to be performed.
 6. Bidder – The individual or entity who submits a Bid directly to the Owner.
 7. Bidding Documents – The Bidding Requirements, Contract Documents, and the General Conditions (including all Addenda).
 8. Bidding Requirements – The Advertisement or Invitation to Bid, Instructions to Bidders, bid security of acceptable form, if any, and the Bid Form with any supplements.
 9. Change Order – A document recommended by the Construction Coordinator which is signed by the Contractor and Owner and authorizes an addition, deletion, or revision in the Work or an adjustment in the Contract Price or the Contract Times, issued on or after the Effective Date of the Agreement.
 10. Claim – A demand or assertion by the Owner or Contractor seeking an adjustment of Contract Price or Contract Times, or both, or other relief with respect to the terms of the Contract. A demand for money or services by a third party is not a Claim.
 11. Construction Coordinator - The person or firm in charge of the project. The person or firm will be selected by the owner and in some instances, the owner will self-perform, acting as the Construction Coordinator. The firm could be an Architectural Firm, Engineering Firm, or third party as so designated by the owner.

12. Contract – The entire and integrated written agreement between the Owner and Contractor including the General Conditions concerning the Work. The Contract supersedes prior negotiations, representations, or agreements, whether written or oral.
13. Contract Documents – Those items so designated in the Agreement. Only printed or hard copies of the items listed in the Agreement Are Contract Documents. Approved Shop Drawings, other Contractor submittals, and the reports and drawings of subsurface and physical conditions are not Contract Documents.
14. Contract Price – The money payable by the Owner to the Contractor for completion of the Work in accordance with the Contract Documents as stated in the Agreement (subject to the provisions of Paragraph 11.03 in the case of Unit Price Work).
15. Contract Times – The number of days or the dates stated in the Agreement to: (i) achieve Milestones, if any, (ii) achieve Substantial Completion; and (iii) complete the Work so that it is ready for final payment as evidenced by Engineer's written recommendation of final payment.
16. Contractor – The individual or entity with whom Owner has entered into the Agreement.
17. Cost of the Work – See Paragraph 11.01.A for definition.
18. Drawings – That part of the Contract Documents prepared or approved by the Construction Coordinator which graphically shows the scope, extent, and character of the Work to be performed by the Contractor. Shop Drawings and other Contractor submittals are not Drawings as so defined.
19. Effective Date of the Agreement – The date indicated in the Agreement on which it becomes effective, but if no such date is indicated, it means the date on which the Agreement is signed and delivered by the last of the two parties to sign and deliver.
20. Field Order – A written order issued by the Construction Coordinator which requires minor changes in the Work but which does not involve a change in the Contract Price or the Contract Times.
21. General Requirements – Sections of Division 1 of the Specifications. The General Requirements pertain to all sections of the Specifications.
22. Hazardous Environmental Condition – The presence at the Site of Asbestos, PCBs, Petroleum, Hazardous Waste, or Radioactive Material in such quantities or circumstances that may present a substantial danger to persons or property exposed thereto in connection with the Work.
23. Hazardous Waste – The term Hazardous Waste shall have the meaning provided in Section 1004 of the Solid Waste Disposal Act (42 USC Section 6903) as amended from time to time.
24. Laws and Regulations; Laws or Regulations – Any and all applicable laws, rules, regulations, ordinances, codes, and orders of any and all governmental bodies, agencies, authorities, and courts having jurisdiction.
25. Liens – Charges, security interests, or encumbrances upon Project funds, real property, or personal property.
26. Milestone – A principal event specified in the Contract Documents relating to an intermediate completion date or time prior to Substantial Completion of all the Work.

27. Notice of Award – The written notice by Owner to the Successful Bidder stating that upon timely compliance by the Successful Bidder with the conditions precedent listed therein, the Owner will sign and deliver the Agreement.
28. Notice to Proceed – A written notice given by Owner or Construction Coordinator to Contractor fixing the date on which the Contract Times will commence to run and on which Contractor shall start to perform the Work under the Contract Documents.
29. Owner – The individual or entity with whom Contractor has entered into the Agreement and for whom the Work is to be performed.
30. PCBs – Polychlorinated biphenyls.
31. Petroleum – Petroleum, including crude oil or any fraction thereof which is liquid at standard conditions of temperature and pressure (60 degrees Fahrenheit and 14.7 pounds per square inch absolute), such as oil, petroleum, fuel oil, oil sludge, oil refuse, gasoline, kerosene, and oil mixed with other non-Hazardous Waste and crude oils.
32. Progress Schedule – A schedule, prepared and maintained by Contractor, describing the sequence and duration of the activities comprising the Contractor's plan to accomplish the Work within the Contract Times.
33. Project – The total construction of which the Work to be performed under the Contract Documents may be the whole, or a part.
34. Project Manual – The bound documentary information prepared for bidding and constructing the Work. A listing of the contents of the Project Manual, which may be bound in one or more volumes, is contained in the table(s) of contents.
35. Radioactive Material – Source, special nuclear, or byproduct material as defined by the Atomic Energy Act of 1954 (42 USC Section 2011 et seq.) as amended from time to time.
36. Related Entity – An officer, director, partner, employee, agent, consultant, or subcontractor.
37. Resident Project Representative – The authorized representative of the Construction Coordinator who may be assigned to the Site or any part thereof.
38. Samples – Physical examples of materials, equipment, or workmanship that are representative of some portion of the Work and which establish the standards by which such portion of the Work will be judged.
39. Schedule of Submittals – A schedule, prepared and maintained by Contractor, of required submittals and the time requirements to support the scheduled performance of related construction activities.
40. Schedule of Values – A schedule, prepared and maintained by Contractor, allocating portions of the Contract Price to various portions of the Work and used as the basis for reviewing Contractor's Applications for Payment.
41. Shop Drawings – All drawings, diagrams, illustrations, schedules, and other data or information which are specifically prepared or assembled by or for Contractor and submitted by Contractor to illustrate some portion of the Work.
42. Site – Lands or areas indicated in the Contract Documents as being furnished by the Owner upon which the Work is to be performed, including rights-of-way and easements for access

thereto, and such other lands furnished by the Owner which are designated for the use of Contractor.

43. Specifications – That part of the Contract Documents consisting of written requirements for materials, equipment, systems, standards, and workmanship as applied to the Work, and certain administrative requirements and procedural matters applicable thereto.
44. Subcontractor – An individual or entity having a direct contract with the Contractor or with any other Subcontractor for the performance of a part of the Work at the Site.
45. Substantial Completion – The time at which the Work (or a specified part thereof) has progressed to the point where, in the opinion of the Construction Coordinator, the Work (or a specified part thereof) is sufficiently complete, in accordance with the Contract Documents, so that the Work (or a specified part thereof) can be utilized for the purposes for which it is intended. The terms “substantially complete” and “substantially completed” as applied to all or part of the Work refer to Substantial Completion thereof.
46. Successful Bidder – The Bidder submitting a responsive Bid to whom Owner makes an award.
47. Supplementary Conditions – That part of the Contract Documents which amends or supplements these General Conditions.
48. Supplier – A manufacturer, fabricator, supplier, distributor, material man, or vendor having a direct contract with the Contractor or with any Subcontractor to furnish materials or equipment to be incorporated in the Work by the Contractor or any Subcontractor.
49. Underground Facilities – All underground pipelines, conduits, ducts, cables, wires, manholes, vaults, tanks, tunnels, or other such facilities or attachments, and any encasements containing such facilities, including those that convey electricity, gases, steam, liquid petroleum products, telephone or other communications, cable television, water, wastewater, storm water, other liquids or chemicals, or traffic or other control systems.
50. Unit Price Work – Work to be paid for on the basis of unit prices.
51. Work – The entire construction or the various separately identifiable parts thereof required to be provided under the Contract Documents. Work includes and is the result of performing or providing all labor, services, and documentation necessary to produce such construction, and furnishing, installing, and incorporating all materials and equipment into such construction, all as required by the Contract Documents.
52. Work Change Directive – A written statement to the Contractor issued on or after the Effective Date of the Agreement and signed by the Owner and recommended by the Construction Coordinator ordering an addition, deletion, or revision in the Work, or responding to differing or unforeseen subsurface or physical conditions under which the Work is to be performed or to emergencies. A Work Change Directive will not change the Contract Price or the Contract Times but is evidence that the parties expect that the change ordered or documented by a Work Change Directive will be incorporated in a subsequently issued Change Order following negotiations by the parties as to its effect, if any, on the Contract Price or Contract Times.
53. Warranty- Such time period as stated in the contract, which shall cover all workmanship and products installed under the contract requirements.

1.02 Terminology

- A. The following words or terms are not defined but, when used in the Bidding Requirements or Contract Documents, have the following meaning.
- B. Intent of Certain Terms or Adjectives
1. The Contract Documents include the terms “as allowed,” “as approved,” “as ordered,” “as directed” or terms of like effect or import to authorize an exercise of professional judgment by the Construction Coordinator. In addition, the adjectives “reasonable,” “suitable,” “acceptable,” “proper,” “satisfactory,” or adjectives of like effect or import are used to describe an action or determination of the Construction Coordinator as to the Work. It is intended that such exercise of professional judgment, action or determination will be solely to evaluate, in general, the Work for compliance with the requirements of and information in the Contract Documents and conformance with the design concept of the completed Project as a functioning whole as shown or indicated in the Contract Documents (unless there is a specific statement indicating otherwise). The use of any such term or adjective is not intended to and shall not be effective to assign to the Construction Coordinator any duty or authority to supervise or direct the performance of the Work or any duty or authority to undertake responsibility contrary to the provisions of Paragraph 9.09 or any other provision of the Contract Documents.
- C. Day
1. The word “day” means a calendar day of 24 hours measured from midnight to the next midnight.
 2. The wording “business day” means any day Monday thru Friday.
- D. Defective
1. The word “defective,” when modifying the word “Work,” refers to Work that is unsatisfactory, faulty, or deficient in that it:
 - a. does not conform to the Contract Documents, or
 - b. does not meet the requirements of any applicable inspection, reference standard, test, or approval referred to in the Contract Documents, or
 - c. has been damaged prior to the Construction Coordinator’s recommendation of final payment (unless responsibility for the protection thereof has been assumed by Owner at Substantial Completion in accordance with Paragraph 14.04 or 14.05).
- E. Furnish, Install, Perform, Provide
1. The word “furnish,” when used in connection with services, materials, or equipment, shall mean to supply and deliver said services, materials, or equipment to the Site (or some other specified location) ready for use or installation and in usable or operable condition.
 2. The word “install,” when used in connection with services, materials, or equipment, shall mean to put into use or place in final position said services, materials, or equipment complete and ready for intended use.
 3. The words “perform” or “provide,” when used in connection with services, materials, or equipment, shall mean to furnish and install said services, materials, or equipment complete and ready for intended use.

4. When “furnish,” “install,” “perform,” or “provide” is not used in connection with services, materials, or equipment in a context clearly requiring an obligation of Contractor, “provide” is implied.
- F. Unless stated otherwise in the Contract Documents, words or phrases which have a well-known technical or construction industry or trade meaning are used in the Contract Documents in accordance with such recognized meaning.

PART 2 - PRELIMINARY MATTERS

2.01 Delivery of Bonds and Evidence of Insurance

- A. When Contractor delivers the executed counterparts of the Agreement to Owner, Contractor shall also deliver to Owner such bonds as Contractor may be required to furnish.
- B. Evidence of Insurance: Before any Work at the Site is started, Contractor and Owner shall each deliver to the other, with copies to each additional insured identified in the General Conditions, certificates of insurance (and other evidence of insurance which either of them or any additional insured may reasonably request) which Contractor and Owner respectively are required to purchase and maintain in accordance with Part 5.

2.02 Copies of Documents

- A. Owner shall furnish to Contractor up to two (2) printed or hard copies of the Drawings and Project Manual. Additional copies will be furnished upon request at the cost of reproduction.

2.03 Commencement of Contract Times; Notice to Proceed

- A. The Contract Times will commence to run on the thirtieth day after the Effective Date of the Agreement or, if a Notice to Proceed is given, on the day indicated in the Notice to Proceed. A Notice to Proceed may be given at any time within 30 days after the Effective Date of the Agreement. In no event, will the Contract Times commence to run later than the thirtieth day after the Effective Date of the Agreement.

2.04 Starting the Work

- A. Contractor shall start to perform the Work on the date when the Contract Times commence to run. No Work shall be done at the Site prior to the date on which the Contract Times commence to run.

2.05 Before Starting Construction

- A. *Preliminary Schedules:* Within ten (10) days after the Effective Date of the Agreement (unless otherwise specified in the General Requirements), Contractor shall submit to the Construction Coordinator for timely review:
 1. A preliminary Progress Schedule; indicating the times (numbers of days or dates) for starting and completing the various stages of the Work, including any Milestones specified in the Contract Documents;
 2. A preliminary Schedule of Submittals; and
 3. A preliminary Schedule of Values for all of the Work which includes quantities and prices of items which when added together equal the Contract Price and subdivides the Work into component parts in sufficient detail to serve as the basis for progress payments during

performance of the Work. Such prices will include an appropriate amount of overhead and profit applicable to each item of Work.

2.06 Preconstruction Conference

- A. Before any Work at the Site is started, a conference attended by Owner, Contractor, the Construction Coordinator, and others as appropriate will be held to establish a working understanding among the parties as to the Work and to discuss the schedules referred to in Paragraph 2.05.A, procedures for handling Shop Drawings and other submittals, processing Applications for Payment, and maintaining required records.

2.07 Initial Acceptance of Schedules

- A. At least ten (10) days before submission of the first Application for Payment a conference attended by Contractor, the Construction Coordinator, and others as appropriate will be held to review for acceptability to the Construction Coordinator as provided below the schedules submitted in accordance with Paragraph 2.05.A. Contractor shall have an additional ten (10) days to make corrections and adjustments and to complete and resubmit the schedules. No progress payment shall be made to Contractor until acceptable schedules are submitted to the Construction Coordinator.
 - 1. The Progress Schedule will be acceptable to the Construction Coordinator if it provides an orderly progression of the Work to completion within the Contract Times. Such acceptance will not impose on the Construction Coordinator responsibility for the Progress Schedule, for sequencing, scheduling, or progress of the Work nor interfere with or relieve Contractor from Contractor's full responsibility therefor.
 - 2. Contractor's Schedule of Submittals will be acceptable to the Construction Coordinator if it provides a workable arrangement for reviewing and processing the required submittals.
 - 3. Contractor's Schedule of Values will be acceptable to the Construction Coordinator as to form and substance if it provides a reasonable allocation of the Contract Price to component parts of the Work.

PART 3 – CONTRACT DOCUMENTS: INTENT, AMENDING, REUSE

3.01 Intent

- A. The Contract Documents are complementary; what is required by one is as binding as if required by all.
- B. It is the intent of the Contract Documents to describe a functionally complete Project (or part thereof) to be constructed in accordance with the Contract Documents. Any labor, documentation, services, materials, or equipment that may reasonably be inferred from the Contract Documents or from prevailing custom or trade usage as being required to produce the intended result will be provided whether or not specifically called for at no additional cost to Owner.
- C. Clarifications and interpretations of the Contract Documents shall be issued by the Construction Coordinator as provided in Part 9.

3.02 Reference Standards

- A. Standards, Specifications, Codes, Laws, and Regulations
 - 1. Reference to standards, specifications, manuals, or codes of any technical society, organization, or association, or to Laws or Regulations, whether such reference be specific

or by implication, shall mean the standard, specification, manual, code, or Laws or Regulations in effect at the time of opening of Bids (or on the Effective Date of the Agreement if there were no Bids), except as may be otherwise specifically stated in the Contract Documents.

2. No provision of any such standard, specification, manual or code, or any instruction of a Supplier shall be effective to change the duties or responsibilities of Owner, Contractor, or the Construction Coordinator, or any of their subcontractors, consultants, agents, employees from those set forth in the Contract Documents. No such provision or instruction shall be effective to assign to Owner, or the Construction Coordinator, or any of, their Related Entities, any duty or authority to supervise or direct the performance of the Work or any duty or authority to undertake responsibility inconsistent with the provisions of the Contract Documents.

3.03 Reporting and Resolving Discrepancies

A. Reporting Discrepancies

1. *Contractor's Review of Contract Documents before Starting Work:* Before undertaking each part of the Work, Contractor shall carefully study and compare the Contract Documents and check and verify pertinent figures therein and all applicable field measurements. Contractor shall promptly report in writing to the Construction Coordinator any conflict, error, ambiguity, or discrepancy which Contractor may discover and shall obtain a written interpretation or clarification from the Construction Coordinator before proceeding with any Work affected thereby.
2. *Contractor's Review of Contract Documents During Performance of Work:* If, during the performance of the Work, Contractor discovers any conflict, error, ambiguity, or discrepancy within the Contract Documents or between the Contract Documents and any provision of any Law or Regulation applicable to the performance of the Work or of any standard, specification, manual or code, or of any instruction of any Supplier, Contractor shall promptly report it to the Construction Coordinator in writing. Contractor shall not proceed with the Work affected thereby (except in an emergency as required by Paragraph 6.16.A) until an amendment or supplement to the Contract Documents has been issued by one of the methods indicated in Paragraph 3.04.
3. Contractor shall not be liable to Owner or the Construction Coordinator for failure to report any conflict, error, ambiguity, or discrepancy in the Contract Documents unless Contractor knew or reasonably should have known thereof.

B. Resolving Discrepancies

1. Except as may be otherwise specifically stated in the Contract Documents, the provisions of the Contract Documents shall take precedence in resolving any conflict, error, ambiguity, or discrepancy between the provisions of the Contract Documents and:
 - a. the provisions of any standard, specification, manual, code, or instruction (whether or not specifically incorporated by reference in the Contract Documents); or
 - b. the provisions of any Laws or Regulations applicable to the performance of the Work (unless such an interpretation of the provisions of the Contract Documents would result in violation of such Law or Regulation).

3.04 Amending and Supplementing Contract Documents

- A. The Contract Documents may be amended to provide for additions, deletions, and revisions in the Work or to modify the terms and conditions thereof by either a Change Order or a Work Change Directive.
- B. The requirements of the Contract Documents may be supplemented and minor variations and deviations in the Work may be authorized, by one or more of the following ways:
 - 1. A Field Order;
 - 2. Construction Coordinator approval of a Shop Drawing or Sample; (Subject to the provisions of Paragraph 6.17.D.3); or
 - 3. Construction Coordinator written interpretation or clarification.

3.05 Reuse of Documents

- A. Contractor and any Subcontractor or Supplier or other individual or entity performing or furnishing all of the Work under a direct or indirect contract with Contractor, shall not:
 - 1. Have or acquire any title to or ownership rights in any of the Drawings, Specifications, or other documents (or copies of any thereof) prepared by or bearing the seal of Architects, Engineer or Architects and or Engineer's consultants, including electronic media editions; or
 - 2. Reuse any of such Drawings, Specifications, other documents, or copies thereof on extensions of the Project or any other project without written consent of Owner and Architect or Engineer and specific written verification or adaption by Architect or Engineer.
- B. The prohibition of this Paragraph 3.05 will survive final payment, or termination of the Contract. Nothing herein shall preclude Contractor from retaining copies of the Contract Documents for record purposes.

3.06 Electronic Data

- A. Copies of data furnished by Owner or the Construction Coordinator to Contractor or Contractor to Owner or the Construction Coordinator that may be relied upon are limited to the printed copies (also known as hard copies). Files in electronic media format of text, data, graphics, or other types are furnished only for the convenience of the receiving party. Any conclusion or information obtained or derived from such electronic files will be at the user's sole risk. If there is a discrepancy between the electronic files and the hard copies, the hard copies govern.
- B. Because data stored in electronic media format can deteriorate or be modified inadvertently or otherwise without authorization of the data's creator, the party receiving electronic files agrees that it will perform acceptance tests or procedures within 60 days, after which the receiving party shall be deemed to have accepted the data thus transferred. Any errors detected within the 60-day acceptance period will be corrected by the transferring party.
- C. When transferring documents in electronic media format, the transferring party makes no representations as to long term compatibility, usability, or readability of documents resulting from the use of software application packages, operating systems, or computer hardware differing from those used by the data's creator.

PART 4 - AVAILABILITY OF LANDS; SUBSURFACE AND PHYSICAL CONDITIONS; HAZARDOUS ENVIRONMENTAL CONDITIONS; REFERENCE POINTS

4.01 Availability of Lands

- A. Owner shall furnish the Site. Owner shall notify Contractor of any encumbrances or restrictions not of general application but specifically related to use of the Site with which Contractor must comply in performing the Work. Owner will obtain in a timely manner and pay for easements for permanent structures or permanent changes in existing facilities. If Contractor and Owner are unable to agree on entitlement to or on the amount or extent, if any, of any adjustment in the Contract Price or Contract Times, or both, as a result of any delay in Owner's furnishing the Site or a part thereof, Contractor may make a Claim therefor as provided in Paragraph 10.05.
- B. Upon reasonable written request, Owner shall furnish Contractor with a current statement of record legal title and legal description of the lands upon which the Work is to be performed and Owner's interest therein as necessary for giving notice of or filing a mechanic's or construction lien against such lands in accordance with applicable Laws and Regulations.
- C. Contractor shall provide for all additional lands and access thereto that may be required for temporary construction facilities or storage of materials and equipment.

4.02 Subsurface and Physical Conditions

- A. Reports and Drawings: Reports of explorations and tests of subsurface conditions at or contiguous to the Site have been included in the specification documents. The contractor should insure that capable soils are found for any and all compacted surfaces.

4.03 Differing Subsurface or Physical Conditions

- A. Notice: If Contractor believes that any subsurface or physical condition at or contiguous to the Site that is uncovered or revealed either:
 - 1. Is of such a nature as to establish that any "technical data" on which Contractor is entitled to rely as provided in Paragraph 4.02 is materially inaccurate; or
 - 2. Is of such a nature as to require a change in the Contract Documents; or
 - 3. Differs materially from that shown or indicated in the Contract Documents; or
 - 4. Is of an unusual nature, and differs materially from conditions ordinarily encountered and generally recognized as inherent in work of the character provided for in the Contract Documents; then Contractor shall, promptly after becoming aware thereof and before further disturbing the subsurface or physical conditions or performing any Work in connection therewith (except in an emergency as required by Paragraph 6.16.A), notify Owner and the Construction Coordinator in writing about such condition. Contractor shall not further disturb such condition or perform any Work in connection therewith (except as aforesaid) until receipt of written order to do so.
- B. Construction Coordinator Review: After receipt of written notice as required by Paragraph 4.03.A, Construction Coordinator will promptly review the pertinent condition, determine the necessity of Owner's obtaining additional exploration or tests with respect thereto, and advise Owner in writing (with a copy to Contractor) of the Construction Coordinator findings and conclusions.
- C. Possible Price and Times Adjustments
 - 1. The Contract Price or the Contract Times, or both, will be equitably adjusted to the extent that the existence of such differing subsurface or physical condition causes an increase or

decrease in Contractor's cost of, or time required for, performance of the Work; subject, however, to the following:

- a. such condition must meet any one or more of the categories described in Paragraph 4.03.A; and
 - b. with respect to Work that is paid for on a Unit Price Basis, any adjustment in Contract Price will be subject to the provisions of Paragraphs 9.07 and 11.03.
2. Contractor shall not be entitled to any adjustment in the Contract Price or Contract Times if:
- a. Contractor knew of the existence of such conditions at the time Contractor made a final commitment to Owner with respect to Contract Price and Contract Times by the submission of a Bid or becoming bound under a negotiated contract; or
 - b. the existence of such condition could reasonably have been discovered or revealed as a result of any examination, investigation, exploration, test, or study of the Site and contiguous areas required by the Bidding Requirements or Contract Documents to be conducted by or for Contractor prior to Contractor's making such final commitment; or
 - c. Contractor failed to give the written notice as required by Paragraph 4.03.A.
3. If Owner and Contractor are unable to agree on entitlement to or on the amount or extent, if any, of any adjustment in the Contract Price or Contract Times, or both, a Claim may be made therefor as provided in Paragraph 10.05. However, Owner and the Construction Coordinator, and any of their Related Entities shall not be liable to Contractor for any claims, costs, losses, or damages (including but not limited to all fees and charges of engineers, architects, attorneys, and other professionals and all court or arbitration or other dispute resolution costs) sustained by Contractor on or in connection with any other project or anticipated project.

4.04 Underground Facilities

- A. Shown or Indicated: The information and data shown or indicated in the Contract Documents with respect to existing Underground Facilities at or contiguous to the Site is based on information and data furnished to Owner or the Construction Coordinator by the owners of such Underground Facilities, including Owner, or by others:
1. Owner and Construction Coordinator shall not be responsible for the accuracy or completeness of any such information or data; and
 2. The cost of all of the following will be included in the Contract Price, and Contractor shall have full responsibility for:
 - a. reviewing and checking all such information and data,
 - b. locating all Underground Facilities shown or indicated in the Contract Documents,
 - c. coordination of the Work with the owners of such Underground Facilities, including Owner, during construction, and
 - d. the safety and protection of all such Underground Facilities and repairing any damage thereto resulting from the Work.
- B. Not Shown or Indicated

1. If an Underground Facility is uncovered or revealed at or contiguous to the Site which was not shown or indicated, or not shown or indicated with reasonable accuracy in the Contract Documents, Contractor shall, promptly after becoming aware thereof and before further disturbing conditions affected thereby or performing any Work in connection therewith (except in an emergency as required by Paragraph 6.16.A), identify the owner of such Underground Facility and give written notice to that owner and to Owner and the Construction Coordinator. Construction Coordinator will promptly review the Underground Facility and determine the extent, if any, to which a change is required in the Contract Documents to reflect and document the consequences of the existence or location of the Underground Facility. During such time, Contractor shall be responsible for the safety and protection of such Underground Facility.
2. If the Construction Coordinator concludes that a change in the Contract Documents is required, a Work Change Directive or a Change Order will be issued to reflect and document such consequences. An equitable adjustment shall be made in the Contract Price or Contract Times, or both, to the extent that they are attributable to the existence or location of any Underground Facility that was not shown or indicated or not shown or indicated with reasonable accuracy in the Contract Documents and that Contractor did not know of and could not reasonably have been expected to be aware of or to have anticipated. If Owner and Contractor are unable to agree on entitlement to or on the amount or extent, if any, of any such adjustment in Contract Price or Contract Times, Owner or Contractor may make a Claim therefor as provided in Paragraph 10.05.

4.05 Reference Points

- A. Owner shall provide engineering surveys to establish reference points for construction which in the Construction Coordinator judgment are necessary to enable Contractor to proceed with the Work. Contractor shall be responsible for laying out the Work, shall protect and preserve the established reference points and property monuments, and shall make no changes or relocations without the prior written approval of Owner. Contractor shall report to the Construction Coordinator whenever any reference point or property monument is lost or destroyed or requires relocation because of necessary changes in grades or locations, and shall be responsible for the accurate replacement or relocation of such reference points or property monuments by professionally qualified personnel.

4.06 Hazardous Environmental Condition at Site

- A. Reports: See S&ME report attached as exhibit "A".

PART 5 - BONDS AND INSURANCE

5.01 Performance, Payment, and Other Bonds

- A. Contractor shall furnish performance and payment bonds, each in an amount at least equal to the Contract Price as security for the faithful performance and payment of all of Contractor's obligations under the Contract Documents. These bonds shall remain in effect until one year after the date when final payment becomes due or until completion of the correction period specified in Paragraph 13.07, whichever is later, except as provided otherwise by Laws or Regulations or by the Contract Documents. Contractor shall also furnish such other bonds as are required by the Contract Documents.
- B. All bonds shall be in the form prescribed by the Contract Documents except as provided otherwise by Laws or Regulations, and shall be executed by such sureties as are named in the current list of "Companies Holding Certificates of Authority as Acceptable Sureties on Federal Bonds and as Acceptable Reinsuring Companies" as published in Circular 570 (amended) by the Financial Management Service, Surety Bond Branch, U.S. Department of the Treasury. All

bonds signed by an agent must be accompanied by a certified copy of the agent's authority to act.

- C. If the surety on any bond furnished by Contractor is declared bankrupt or becomes insolvent or its right to do business is terminated in any state where any part of the Project is located or it ceases to meet the requirements of Paragraph 5.01.B, Contractor shall promptly notify Owner and the Construction Coordinator and shall, within 20 days after the event giving rise to such notification, provide another bond and surety, both of which shall comply with the requirements of Paragraphs 5.01.B and 5.02.

5.02 Licensed Sureties and Insurers

- A. All bonds and insurance required by the Contract Documents to be purchased and maintained by Owner or Contractor shall be obtained from surety or insurance companies that are duly licensed or authorized in the jurisdiction in which the Project is located to issue bonds or insurance policies for the limits and coverages so required. Such surety and insurance companies shall also meet such additional requirements and qualifications.

5.03 Certificates of Insurance

- A. Contractor shall deliver to Owner, with copies to each additional insured, certificates of insurance (and other evidence of insurance requested by Owner or any other additional insured) which Contractor is required to purchase and maintain.
- B. Owner shall deliver to Contractor, with copies to each additional insured, certificates of insurance (and other evidence of insurance requested by Contractor or any other additional insured) which Owner is required to purchase and maintain.
- C. Failure of Owner to demand such certificates or other evidence of full compliance with these insurance requirements or failure of Owner to identify a deficiency from evidence provided shall not be construed as a waiver of Contractor's obligation to maintain such insurance.
- D. By requiring such insurance and insurance limits herein, Owner does not represent that coverage and limits will necessarily be adequate to protect contractor and such coverage and limits shall not be deemed as a limitation on Contractor's liability under the indemnities granted to Owner in the Contract Documents.

5.04 Contractor's Liability Insurance

- A. Contractor shall purchase and maintain such liability and other insurance as is appropriate for the Work being performed and as will provide protection from claims set forth below which may arise out of or result from Contractor's performance of the Work and Contractor's other obligations under the Contract Documents, whether it is to be performed by Contractor, any Subcontractor or Supplier, or by anyone directly or indirectly employed by any of them to perform any of the Work, or by anyone for whose acts any of them may be liable:
 - 1. claims under workers' compensation, disability benefits, and other similar employee benefit acts;
 - 2. claims for damages because of bodily injury, occupational sickness or disease, or death of Contractor's employees;
 - 3. claims for damages because of bodily injury, sickness or disease, or death of any person other than Contractor's employees;

4. claims for damages insured by reasonably available personal injury liability coverage which are sustained:
 - a. by any person as a result of an offense directly or indirectly related to the employment of such person by Contractor, or
 - b. by any other person for any other reason;
 5. claims for damages, other than to the Work itself, because of injury to or destruction of tangible property wherever located, including loss of use resulting therefrom; and
 6. claims for damages because of bodily injury or death of any person or property damage arising out of the ownership, maintenance or use of any motor vehicle.
- B. The policies of insurance required by this Paragraph 5.04 shall:
1. with respect to insurance required by Paragraphs 5.04.A.3 through 5.04.A.6 inclusive, include as additional insured (subject to any customary exclusion regarding professional liability) Owner and Construction Coordinator, and any other individuals or entities, all of whom shall be listed as additional insureds, and include coverage for the respective officers, directors, partners, employees, agents, consultants and subcontractors of each and any of all such additional insureds, and the insurance afforded to these additional insureds shall provide primary coverage for all claims covered thereby;
 2. include at least the specific coverages and be written for not less than the limits of liability provided or required by Laws or Regulations, whichever is greater;
 3. include completed operations insurance;
 4. include contractual liability insurance covering Contractor's indemnity obligations under Paragraphs 6.11 and 6.20;
 5. contain a provision or endorsement that the coverage afforded will not be canceled, materially changed or renewal refused until at least 30 days' prior written notice has been given to Owner and Contractor and to each other additional insured to whom a certificate of insurance has been issued (and the certificates of insurance furnished by the Contractor pursuant to Paragraph 5.03 will so provide);
 6. remain in effect at least until final payment and at all times thereafter when Contractor may be correcting, removing, or replacing defective Work in accordance with Paragraph 13.07; and
 7. with respect to completed operations insurance, and any insurance coverage written on a claims-made basis, remain in effect for at least two years after final payment.
 - a. Contractor shall furnish Owner and each other additional insured to whom a certificate of insurance has been issued, evidence satisfactory to Owner and any such additional insured of continuation of such insurance at final payment and one year thereafter.
- C. The limits of liability for the insurance required by Paragraph 5.04 of the General Conditions shall provide coverage for not less than the following amounts or greater where required by Laws and Regulations:
1. Workers' Compensation, and related coverages under Paragraphs 5.04.A.1 and A.2 of the General Conditions:
 - a. State: South Carolina

Statutory Benefits

- b. Applicable Federal (e.g., Longshoreman's): Statutory
 - c. Employer's Liability:
 - Each Accident \$1,000,000
 - Disease-Policy Limit \$500,000
 - Disease-Each Employee \$500,000
2. Contractor's General Liability under Paragraphs 5.04.A.3 through A.6 of the General Conditions which shall include completed operations and product liability coverages and eliminate the exclusion with respect to property under the care, custody and control of Contractor and for this project only:
- a. General Aggregate \$2,000,000
 - b. Products - Completed Operations Aggregate \$2,000,000
 - c. Personal and Advertising Injury \$1,000,000
 - d. Each Occurrence (Bodily Injury and Property Damage) \$1,000,000
 - e. Fire Damage (any one (1) fire) \$50,000
 - f. Medical Expense (any one (1) person) \$5,000
 - g. Property Damage liability insurance will provide Explosion, Collapse, and Under-ground coverages where applicable.
 - h. Excess or Umbrella Liability
 - 1) General Aggregate \$2,000,000
 - 2) Each Occurrence \$2,000,000
3. Automobile Liability under Paragraph 5.04.A.6 of the General Conditions:
- a. Include coverage for all owned, hired and non-owned automobiles.
 - b. Combined Single Limit of \$1,000,000
 - c. Each Occurrence \$1,000,000
 - d. Limits Medical Expense \$5,000
4. The Contractual Liability coverage required by Paragraph 5.04.B.4 of the General Conditions shall provide coverage for not less than the following amounts:
- a. Bodily Injury:
 - Each Accident \$2,000,000
 - Annual Aggregate \$2,000,000
 - b. Property Damage:
 - Each Accident \$2,000,000
 - Annual Aggregate \$2,000,000

5. Flood Insurance: The Contractor is required to carry flood insurance for projects located in designated flood hazard areas in which Federal Flood Insurance is available.

5.05 Owner's Liability Insurance

- A. In addition to the insurance required to be provided by Contractor under Paragraph 5.04, Owner, at Owner's option, may purchase and maintain at Owner's expense Owner's own liability insurance as will protect Owner against claims which may arise from operations under the Contract Documents.

5.06 Property Insurance

- A. Contractor shall purchase and maintain property insurance upon the Work at the Site in the amount of the full replacement cost thereof.
 1. This insurance shall:
 - a. includes the interests of Owner, Contractor, Subcontractors, Construction Coordinator and any other individuals or entities identified herein, and the officers, directors, partners, employees, agents and other consultants and subcontractors of any of them each of whom is deemed to have an insurable interest and shall be listed as an insured or additional insured;
 - b. in addition to the individuals and entities specified, include as additional insureds, the following:
 - c. be written on a Builder's Risk "all-risk" or open peril or special causes of loss policy form that shall at least include insurance for physical loss and damage to the Work, temporary buildings, falsework, and materials and equipment in transit and shall insure against at least the following perils or causes of loss: fire, lightning, extended coverage, theft, vandalism and malicious mischief, earthquake, collapse, debris removal, demolition occasioned by enforcement of Laws and Regulations, water damage (other than that caused by flood), and such other perils or causes of loss as may be specifically required;
 - d. includes expenses incurred in the repair or replacement of any insured property (including but not limited to fees and charges of engineers and architects);
 - e. cover materials and equipment stored at the Site or at another location that was agreed to in writing by Owner prior to being incorporated in the Work, provided that such materials and equipment have been included in an Application for Payment recommended by the Construction Coordinator;
 - f. allows for partial utilization of the Work by Owner;
 - g. includes testing and startup; and
 - h. be maintained in effect until final payment is made unless otherwise agreed to in writing by Owner, Contractor and the Construction Coordinator with 30 days' written notice to each other additional insured to whom a certificate of insurance has been issued.
 2. Contractor shall be responsible for any deductible or self-insured retention.
 3. The policies of insurance required to be purchased and maintained by Contractor in accordance with this Paragraph SC-5.06 A, shall comply with the requirements of paragraph 5.06.C of the General Conditions.

- B. Owner shall purchase and maintain such boiler and machinery insurance or additional property insurance as may be required Laws and Regulations which will include the interests of Owner, Contractor, Subcontractors, and Construction Coordinator, and any other individuals or entities identified, and the officers, directors, partners, employees, agents, consultants and subcontractors of each and any of them, each of whom is deemed to have an insurable interest and shall be listed as an insured or additional insured.
- C. All the policies of insurance (and the certificates or other evidence thereof) required to be purchased and maintained in accordance with Paragraph 5.06 will contain a provision or endorsement that the coverage afforded will not be canceled or materially changed or renewal refused until at least thirty (30) days prior written notice has been given to Owner and Contractor and to each other additional insured to whom a certificate of insurance has been issued and will contain waiver provisions in accordance with Paragraph 5.07.
- D. Owner shall not be responsible for purchasing and maintaining any property insurance specified in this Paragraph 5.06 to protect the interests of Contractor, Subcontractors, or others in the Work to the extent of any deductible amounts that are identified. The risk of loss within such identified deductible amount will be borne by Contractor, Subcontractors, or others suffering any such loss, and if any of them wishes property insurance coverage within the limits of such amounts, each may purchase and maintain it at the purchaser's own expense.

5.07 Waiver of Rights

- A. Owner and Contractor intend that all policies purchased in accordance with Paragraph 5.06 will protect Owner, Contractor, Subcontractors, and Construction Coordinator, and all other individuals or entities identified to be listed as insureds or additional insureds (and the officers, directors, partners, employees, agents, consultants and subcontractors of each and any of them) in such policies and will provide primary coverage for all losses and damages caused by the perils or causes of loss covered thereby. All such policies shall contain provisions to the effect that in the event of payment of any loss or damage the insurers will have no rights of recovery against any of the insureds or additional insureds thereunder. Owner and Contractor waive all rights against each other and their respective officers, directors, partners, employees, agents, consultants and subcontractors of each and any of them for all losses and damages caused by, arising out of or resulting from any of the perils or causes of loss covered by such policies and any other property insurance applicable to the Work; and, in addition, waive all such rights against Subcontractors, and the Construction Coordinator, and all other individuals or entities identified to be listed as insured or additional insured (and the officers, directors, partners, employees, agents, consultants and subcontractors of each and any of them) under such policies for losses and damages so caused. None of the above waivers shall extend to the rights that any party making such waiver may have to the proceeds of insurance held by Owner as trustee or otherwise payable under any policy so issued.
- B. Any insurance policy maintained by Owner covering any loss, damage or consequential loss referred to in Paragraph 5.07.B shall contain provisions to the effect that in the event of payment of any such loss, damage, or consequential loss, the insurers will have no rights of recovery against Contractor, Subcontractors, or the Construction Coordinator, and the officers, directors, partners, employees, agents, consultants and subcontractors of each and any of them.

5.08 Receipt and Application of Insurance Proceeds

- A. Any insured loss under the policies of insurance required by Paragraph 5.06 will be adjusted with Owner and made payable to Owner as fiduciary for the insureds, as their interests may appear, subject to the requirements of any applicable mortgage clause and of Paragraph 5.08.B. Owner shall deposit in a separate account any money so received and shall distribute it in accordance with such agreement as the parties in interest may reach. If no other special agreement is reached, the damaged Work shall be repaired or replaced, the moneys so

received applied on account thereof, and the Work and the cost thereof covered by an appropriate Change Order.

- B. Owner as fiduciary shall have power to adjust and settle any loss with the insurers unless one of the parties in interest shall object in writing within 15 days after the occurrence of loss to Owner's exercise of this power. If such objection be made, Owner as fiduciary shall make settlement with the insurers in accordance with such agreement as the parties in interest may reach. If no such agreement among the parties in interest is reached, Owner as fiduciary shall adjust and settle the loss with the insurers and, if required in writing by any party in interest, Owner as fiduciary shall give bond for the proper performance of such duties.

5.09 Acceptance of Bonds and Insurance; Option to Replace

- A. If either Owner or Contractor has any objection to the coverage afforded by or other provisions of the bonds or insurance required to be purchased and maintained by the other party in accordance with Part 5 on the basis of nonconformance with the Contract Documents, the objecting party shall so notify the other party in writing within ten (10) days after receipt of the certificates (or other evidence requested) required by Paragraph 2.01.B. Owner and Contractor shall each provide to the other such additional information in respect of insurance provided as the other may reasonably request. If either party does not purchase or maintain all of the bonds and insurance required of such party by the Contract Documents, such party shall notify the other party in writing of such failure to purchase prior to the start of the Work, or of such failure to maintain prior to any change in the required coverage. Without prejudice to any other right or remedy, the other party may elect to obtain equivalent bonds or insurance to protect such other party's interests at the expense of the party who was required to provide such coverage, and a Change Order shall be issued to adjust the Contract Price accordingly.

5.10 Partial Utilization, Acknowledgment of Property Insurer

- A. If Owner finds it necessary to occupy or use a portion or portions of the Work prior to Substantial Completion of all the Work as provided in Paragraph 14.05, no such use or occupancy shall commence before the insurers providing the property insurance pursuant to Paragraph 5.06 have acknowledged notice thereof and in writing effected any changes in coverage necessitated thereby. The insurers providing the property insurance shall consent by endorsement on the policy or policies, but the property insurance shall not be canceled or permitted to lapse on account of any such partial use or occupancy.

PART 6 - CONTRACTOR'S RESPONSIBILITIES

6.01 Supervision and Superintendence

- A. **When working is being performed on site the superintendent must be present, without exception.**
- B. Contractor shall supervise, inspect, and direct the Work competently and efficiently, devoting such attention thereto and applying such skills and expertise as may be necessary to perform the Work in accordance with the Contract Documents. Contractor shall be solely responsible for the means, methods, techniques, sequences, and procedures of construction. Contractor shall not be responsible for the negligence of Owner or the Construction Coordinator in the design or specification of a specific means, method, technique, sequence, or procedure of construction which is shown or indicated in and expressly required by the Contract Documents.
- C. At all times during the progress of the Work, Contractor shall assign a competent resident superintendent who shall not be replaced without written notice to Owner and the Construction Coordinator except under extraordinary circumstances. The superintendent will be Contractor's representative at the Site and shall have authority to act on behalf of Contractor. All communications given to or received from the superintendent shall be binding on Contractor.

6.02 Labor; Working Hours

- A. Contractor shall provide competent, suitably qualified personnel to survey and lay out the Work and perform construction as required by the Contract Documents. Contractor shall at all times maintain good discipline and order at the Site.
- B. Except as otherwise required for the safety or protection of persons or the Work or property at the Site or adjacent thereto, and except as otherwise stated in the Contract Documents, all Work at the Site shall be performed on business days during regular working hours. Contractor will not permit the performance of Work on a Saturday, Sunday, or any legal holiday without Owner's written consent (which will not be unreasonably withheld) given after prior written notice to the Construction Coordinator.

6.03 Services, Materials, and Equipment

- A. Unless otherwise specified in the Contract Documents, Contractor shall provide and assume full responsibility for all services, materials, equipment, labor, transportation, construction equipment and machinery, tools, appliances, fuel, power, light, heat, telephone, water, sanitary facilities, temporary facilities, and all other facilities and incidentals necessary for the performance, testing, startup, and completion of the Work.
- B. All materials and equipment incorporated into the Work shall be as specified or, if not specified, shall be of good quality and new, except as otherwise provided in the Contract Documents. All special warranties and guarantees required by the Specifications shall expressly run to the benefit of Owner. If required by the Construction Coordinator, Contractor shall furnish satisfactory evidence (including reports of required tests) as to the source, kind, and quality of materials and equipment.
- C. All materials and equipment shall be stored, applied, installed, connected, erected, protected, used, cleaned, and conditioned in accordance with instructions of the applicable Supplier, except as otherwise may be provided in the Contract Documents.

6.04 Progress Schedule

- A. Contractor shall adhere to the Progress Schedule established in accordance with Paragraph 2.07 as it may be adjusted from time to time as provided below.
 - 1. Contractor shall submit to the Construction Coordinator for acceptance (to the extent indicated in Paragraph 2.07) proposed adjustments in the Progress Schedule that will not result in changing the Contract Times. Such adjustments will comply with any provisions of the General Requirements applicable thereto.
 - 2. Proposed adjustments in the Progress Schedule that will change the Contract Times shall be submitted in accordance with the requirements of Part 12. Adjustments in Contract Times may only be made by a Change Order.

6.05 Substitutes and "Or-Equals"

- A. Whenever an item of material or equipment is specified or described in the Contract Documents by using the name of a proprietary item or the name of a particular Supplier, the specification or description is intended to establish the type, function, appearance, and quality required. Unless the specification or description contains or is followed by words reading that no like, equivalent, or "or-equal" item or no substitution is permitted, other items of material or equipment or material or equipment of other Suppliers may be submitted to the Construction Coordinator for review under the circumstances described below.

1. "Or-Equal" Items: If in the Construction Coordinators sole discretion an item of material or equipment proposed by Contractor is functionally equal to that named and sufficiently similar so that no change in related Work will be required, it may be considered by Engineer as an "or-equal" item, in which case review and approval of the proposed item may, in Engineer's sole discretion, be accomplished without compliance with some or all of the requirements for approval of proposed substitute items. For the purposes of this Paragraph 6.05.A.1, a proposed item of material or equipment will be considered functionally equal to an item so named if:
 - a. in the exercise of reasonable judgment Engineer determines that:
 - 1) it is at least equal in materials of construction, quality, durability, appearance, strength, and design characteristics;
 - 2) it will reliably perform at least equally well the function and achieve the results imposed by the design concept of the completed Project as a functioning whole,
 - 3) it has a proven record of performance and availability of responsive service; and
 - b. Contractor certifies that, if approved and incorporated into the Work:
 - 1) there will be no increase in cost to the Owner or increase in Contract Times, and
 - 2) it will conform substantially to the detailed requirements of the item named in the Contract Documents.
2. Substitute Items
 - a. If in the Construction Coordinators sole discretion an item of material or equipment proposed by Contractor does not qualify as an "or-equal" item under Paragraph 6.05.A.1, it will be considered a proposed substitute item.
 - b. Contractor shall submit sufficient information as provided below to allow the Construction Coordinator to determine that the item of material or equipment proposed is essentially equivalent to that named and an acceptable substitute therefor. Requests for review of proposed substitute items of material or equipment will not be accepted by the Construction Coordinator from anyone other than Contractor.
 - c. The requirements for review by the Construction Coordinator will be as set forth in Paragraph 6.05.A.2.d, as supplemented in the General Requirements and as the Construction Coordinator may decide is appropriate under the circumstances.
 - d. Contractor shall make written application to the Construction Coordinator for review of a proposed substitute item of material or equipment that Contractor seeks to furnish or use. The application:
 - 1) shall certify that the proposed substitute item will:
 - a) perform adequately the functions and achieve the results called for by the general design,
 - b) be similar in substance to that specified, and
 - c) be suited to the same use as that specified;
 - 2) will state:

- a) the extent, if any, to which the use of the proposed substitute item will prejudice Contractor's achievement of Substantial Completion on time;
 - b) whether or not use of the proposed substitute item in the Work will require a change in any of the Contract Documents (or in the provisions of any other direct contract with Owner for other work on the Project) to adapt the design to the proposed substitute item; and
 - c) whether or not incorporation or use of the proposed substitute item in connection with the Work is subject to payment of any license fee or royalty;
- 3) will identify:
- a) all variations of the proposed substitute item from that specified, and
 - b) available engineering, sales, maintenance, repair, and replacement services;
- 4) and shall contain an itemized estimate of all costs or credits that will result directly or indirectly from use of such substitute item, including costs of redesign and claims of other contractors affected by any resulting change,
- B. Substitute Construction Methods or Procedures: If a specific means, method, technique, sequence, or procedure of construction is expressly required by the Contract Documents, Contractor may furnish or utilize a substitute means, method, technique, sequence, or procedure of construction approved by the Construction Coordinator. Contractor shall submit sufficient information to allow the Construction Coordinator, in the Construction Coordinator's sole discretion, to determine that the substitute proposed is equivalent to that expressly called for by the Contract Documents. The requirements for review by the Construction Coordinator will be similar to those provided in Paragraph 6.05.A 2.
- C. Construction Coordinator Evaluation: The Construction Coordinator will be allowed a reasonable time within which to evaluate each proposal or submittal made pursuant to Paragraphs 6.05.A and 6.05.B. The Construction Coordinator may require Contractor to furnish additional data about the proposed substitute item. The Construction Coordinator will be the sole judge of acceptability. No "or equal" or substitute will be ordered, installed or utilized until the Construction Coordinator's review is complete, which will be evidenced by either a Change Order for a substitute or an approved Shop Drawing for an "or-equal." The Construction Coordinator will advise Contractor in writing of any negative determination.
- D. Special Guarantee: Owner may require Contractor to furnish at Contractor's expense a special performance guarantee or other surety with respect to any substitute.
- E. Cost Reimbursement: The Construction Coordinator will record the Architect or Engineer's costs in evaluating a substitute proposed or submitted by Contractor pursuant to Paragraphs 6.05.A.2 and 6.05.B. Whether or not the Construction Coordinator approves a substitute item so proposed or submitted by Contractor, Contractor shall reimburse Owner for the charges of the Architect or Engineer for evaluating each such proposed substitute. Contractor shall also reimburse Owner for the charges of the Architect or Engineer for making changes in the Contract Documents (or in the provisions of any other direct contract with Owner) resulting from the acceptance of each proposed substitute.
- F. Contractor's Expense: Contractor shall provide all data in support of any proposed substitute or "or-equal" at Contractor's expense.

6.06 Concerning Subcontractors, Suppliers, and Others

- A. Contractor shall not employ any Subcontractor, Supplier, or other individual or entity (including those acceptable to Owner as indicated in Paragraph 6.06.B), whether initially or as a replacement, against whom Owner may have reasonable objection. Contractor shall not be required to employ any Subcontractor, Supplier, or other individual or entity to furnish or perform any of the Work against whom Contractor has reasonable objection.
- B. The identity of certain Subcontractors, Suppliers, or other individuals or entities to be submitted to Owner in advance for acceptance by Owner by a specified date prior to the Effective Date of the Agreement, and if Contractor has submitted a list thereof, Owner's acceptance (either in writing or by failing to make written objection thereto by the date indicated for acceptance or objection in the Bidding Documents or the Contract Documents) of any such Subcontractor, Supplier, or other individual or entity so identified may be revoked on the basis of reasonable objection after due investigation. Contractor shall submit an acceptable replacement for the rejected Subcontractor, Supplier, or other individual or entity, and the Contract Price will be adjusted by the difference in the cost occasioned by such replacement, and an appropriate Change Order will be issued. No acceptance by Owner of any such Subcontractor, Supplier, or other individual or entity, whether initially or as a replacement, shall constitute a waiver of any right of Owner or the Construction Coordinator to reject defective Work.
- C. Contractor shall be fully responsible to Owner and the Construction Coordinator for all acts and omissions of the Subcontractors, Suppliers, and other individuals or entities performing or furnishing any of the Work just as Contractor is responsible for Contractor's own acts and omissions. Nothing in the Contract Documents:
 - 1. shall create for the benefit of any such Subcontractor, Supplier, or other individual or entity any contractual relationship between Owner or the Construction Coordinator and any such Subcontractor, Supplier or other individual or entity, nor
 - 2. shall anything in the Contract Documents create any obligation on the part of Owner or the Construction Coordinator to pay or to see to the payment of any moneys due any such Subcontractor, Supplier, or other individual or entity except as may otherwise be required by Laws and Regulations.
- D. Contractor shall be solely responsible for scheduling and coordinating the Work of Subcontractors, Suppliers, and other individuals or entities performing or furnishing any of the Work under a direct or indirect contract with Contractor.
- E. Contractor shall require all Subcontractors, Suppliers, and such other individuals or entities performing or furnishing any of the Work to communicate with the Construction Coordinator through Contractor.
- F. The divisions and sections of the Specifications and the identifications of any Drawings shall not control Contractor in dividing the Work among Subcontractors or Suppliers or delineating the Work to be performed by any specific trade.
- G. All Work performed for Contractor by a Subcontractor or Supplier will be pursuant to an appropriate agreement between Contractor and the Subcontractor or Supplier which specifically binds the Subcontractor or Supplier to the applicable terms and conditions of the Contract Documents for the benefit of Owner and Construction Coordinator. Whenever any such agreement is with a Subcontractor or Supplier who is listed as an additional insured on the property insurance provided in Paragraph 5.06, the agreement between the Contractor and the Subcontractor or Supplier will contain provisions whereby the Subcontractor or Supplier waives all rights against Owner, Contractor, and Construction Coordinator,, and all other individuals or entities to be listed as insureds or additional insureds (and the officers, directors,

partners, employees, agents, consultants and subcontractors of each and any of them) for all losses and damages caused by, arising out of, relating to, or resulting from any of the perils or causes of loss covered by such policies and any other property insurance applicable to the Work. If the insurers on any such policies require separate waiver forms to be signed by any Subcontractor or Supplier, Contractor will obtain the same.

- H. Owner or Construction Coordinator may furnish to any Subcontractor or Supplier, to the extent practicable, information about amounts paid to Contractor on account of Work performed for Contractor by a particular Subcontractor or Supplier.

6.07 Patent Fees and Royalties

- A. Contractor shall pay all license fees and royalties and assume all costs incident to the use in the performance of the Work or the incorporation in the Work of any invention, design, process, product, or device which is the subject of patent rights or copyrights held by others. If a particular invention, design, process, product, or device is specified in the Contract Documents for use in the performance of the Work and if to the actual knowledge of Owner or Construction Coordinator its use is subject to patent rights or copyrights calling for the payment of any license fee or royalty to others, the existence of such rights shall be disclosed by Owner in the Contract Documents.
- B. To the fullest extent permitted by Laws and Regulations, Contractor shall indemnify and hold harmless Owner and Construction Coordinator, and the officers, directors, partners, employees, agents, consultants and subcontractors of each and any of them from and against all claims, costs, losses, and damages (including but not limited to all fees and charges of engineers, architects, attorneys, and other professionals and all court or arbitration or other dispute resolution costs) arising out of or relating to any infringement of patent rights or copyrights incident to the use in the performance of the Work or resulting from the incorporation in the Work of any invention, design, process, product, or device not specified in the Contract Documents.

6.08 Permits

- A. Contractor shall obtain and pay for all construction permits and licenses. Contractor shall pay all governmental charges and inspection fees necessary for the Work which are applicable at the time of opening of Bids, or, if there are no Bids, on the Effective Date of the Agreement.

6.09 Laws and Regulations

- A. Contractor shall give all notices required by and shall comply with all Laws and Regulations applicable to the performance of the Work. Except where otherwise expressly required by applicable Laws and Regulations, neither Owner nor Construction Coordinator shall be responsible for monitoring Contractor's compliance with any Laws or Regulations.
- B. If Contractor performs any Work knowing or having reason to know that it is contrary to Laws or Regulations, Contractor shall bear all claims, costs, losses, and damages (including but not limited to all fees and charges of engineers, architects, attorneys, and other professionals and all court or arbitration or other dispute resolution costs) arising out of or relating to such Work. However, it shall not be Contractor's primary responsibility to make certain that the Specifications and Drawings are in accordance with Laws and Regulations, but this shall not relieve Contractor of Contractor's obligations under Paragraph 3.03.
- C. Changes in Laws or Regulations not known at the time of opening of Bids (or, on the Effective Date of the Agreement if there were no Bids) having an effect on the cost or time of performance of the Work shall be the subject of an adjustment in Contract Price or Contract Times. If Owner and Contractor are unable to agree on entitlement to or on the amount or extent, if any, of any such adjustment, a Claim may be made therefor as provided in Paragraph 10.05.

6.10 Taxes

- A. Contractor shall pay all sales, consumer, use, and other similar taxes required to be paid by Contractor in accordance with the Laws and Regulations of the place of the Project which are applicable during the performance of the Work.

6.11 Use of Site and Other Areas

- A. Limitation on Use of Site and Other Areas
 - 1. Contractor shall confine construction equipment, the storage of materials and equipment, and the operations of workers to the Site and other areas permitted by Laws and Regulations, and shall not unreasonably encumber the Site and other areas with construction equipment or other materials or equipment. Contractor shall assume full responsibility for any damage to any such land or area, or to the owner or occupant thereof, or of any adjacent land or areas resulting from the performance of the Work.
 - 2. Should any claim be made by any such owner or occupant because of the performance of the Work, Contractor shall promptly settle with such other party by negotiation or otherwise resolve the claim by arbitration or other dispute resolution proceeding or at law.
 - 3. To the fullest extent permitted by Laws and Regulations, Contractor shall indemnify and hold harmless Owner and Construction Coordinator, and the officers, directors, partners, employees, agents, consultants and subcontractors of each and any of them from and against all claims, costs, losses, and damages (including but not limited to all fees and charges of engineers, architects, attorneys, and other professionals and all court or arbitration or other dispute resolution costs) arising out of or relating to any claim or action, legal or equitable, brought by party against Owner, Construction Coordinator, or any other party indemnified hereunder to the extent caused by or based upon Contractor's performance of the Work.
- B. *Removal of Debris During Performance of the Work:* During the progress of the Work Contractor shall keep the Site and other areas free from accumulations of waste materials, rubbish, and other debris. Removal and disposal of such waste materials, rubbish, and other debris shall conform to applicable Laws and Regulations.
- C. *Cleaning:* Prior to Substantial Completion of the Work, Contractor shall clean the Site and the Work and make it ready for utilization by Owner. At the completion of the Work, Contractor shall remove from the Site all tools, appliances, construction equipment and machinery, and surplus materials and shall restore to original condition all property not designated for alteration by the Contract Documents.
- D. *Loading Structures:* Contractor shall not load nor permit any part of any structure to be loaded in any manner that will endanger the structure, nor shall Contractor subject any part of the Work or adjacent property to stresses or pressures that will endanger it.

6.12 Record Documents

- A. Contractor shall maintain in a safe place at the Site one record copy of all Drawings, Specifications, Addenda, Change Orders, Work Change Directives, Field Orders, and written interpretations and clarifications in good order and annotated to show changes made during construction. These record documents together with all approved Samples and a counterpart of all approved Shop Drawings will be available to Construction Coordinator for reference. Upon completion of the Work, these record documents, Samples, and Shop Drawings will be delivered to Construction Coordinator for Owner in digital format as an as-built file.

6.13 Safety and Protection

- A. Contractor shall be solely responsible for initiating, maintaining and supervising all safety precautions and programs in connection with the Work. Contractor shall take all necessary precautions for the safety of, and shall provide the necessary protection to prevent damage, injury or loss to:
 - 1. all persons on the Site or who may be affected by the Work;
 - 2. all the Work and materials and equipment to be incorporated therein, whether in storage on or off the Site; and
 - 3. other property at the Site or adjacent thereto, including trees, shrubs, lawns, walks, pavements, roadways, structures, utilities, and Underground Facilities not designated for removal, relocation, or replacement in the course of construction.
- B. Contractor shall comply with all applicable Laws and Regulations relating to the safety of persons or property, or to the protection of persons or property from damage, injury, or loss; and shall erect and maintain all necessary safeguards for such safety and protection. Contractor shall notify owners of adjacent property and of Underground Facilities and other utility owners when prosecution of the Work may affect them, and shall cooperate with them in the protection, removal, relocation, and replacement of their property.
- C. All damage, injury, or loss to any property referred to in Paragraph 6.13.A.2 or 6.13.A.3 caused, directly or indirectly, in whole or in part, by Contractor, any Subcontractor, Supplier, or any other individual or entity directly or indirectly employed by any of them to perform any of the Work, or anyone for whose acts any of them may be liable, shall be remedied by Contractor (except damage or loss attributable to the fault of Drawings or Specifications or to the acts or omissions of Owner or Construction Coordinator or , or anyone employed by any of them, or anyone for whose acts any of them may be liable, and not attributable, directly or indirectly, in whole or in part, to the fault or negligence of Contractor or any Subcontractor, Supplier, or other individual or entity directly or indirectly employed by any of them).
- D. Contractor's duties and responsibilities for safety and for protection of the Work shall continue until such time as all the Work is completed and Construction Coordinator has issued a notice to Owner and Contractor in accordance with Paragraph 14.07.B that the Work is acceptable (except as otherwise expressly provided in connection with Substantial Completion).

6.14 Safety Representative

- A. Contractor shall designate a qualified and experienced safety representative at the Site whose duties and responsibilities shall be the prevention of accidents and the maintaining and supervising of safety precautions and programs.

6.15 Hazard Communication Programs

- A. Contractor shall be responsible for coordinating any exchange of material safety data sheets or other hazard communication information required to be made available to or exchanged between or among employers at the Site in accordance with Laws or Regulations. All MSDS Sheets shall be kept on site in good order as outlined in OSHA, laws, rules and regulations.

6.16 Emergencies

- A. In emergencies affecting the safety or protection of persons or the Work or property at the Site or adjacent thereto, Contractor is obligated to act to prevent threatened damage, injury, or loss. Contractor shall give Construction Coordinator prompt written notice if Contractor believes that any significant changes in the Work or variations from the Contract Documents have been

caused thereby or are required as a result thereof. If Engineer determines that a change in the Contract Documents is required because of the action taken by Contractor in response to such an emergency, a Work Change Directive or Change Order will be issued.

6.17 Shop Drawings and Samples

- A. Contractor shall submit Shop Drawings and Samples to Construction Coordinator for review and approval in accordance with the acceptable Schedule of Submittals (as required by Paragraph 2.07). Each submittal will be identified as Construction Coordinator may require.
 - 1. Shop Drawings
 - a. Submit number of copies specified in the General Requirements.
 - b. Data shown on the Shop Drawings will be complete with respect to quantities, dimensions, specified performance and design criteria, materials, and similar data to show Construction Coordinator the services, materials, and equipment Contractor proposes to provide and to enable Engineer to review the information for the limited purposes required by Paragraph 6.17.D.
 - 2. Samples: Contractor shall also submit Samples to Construction Coordinator for review and approval in accordance with the acceptable schedule of Shop Drawings and Sample submittals.
 - a. Submit number of Samples specified in the Specifications.
 - b. Clearly identify each Sample as to material, Supplier, pertinent data such as catalog numbers, the use for which intended and other data as Construction Coordinator may require to enable Construction Coordinator to review the submittal for the limited purposes required by Paragraph 6.17.D.
- B. Where a Shop Drawing or Sample is required by the Contract Documents or the Schedule of Submittals, any related Work performed prior to Construction Coordinator's review and approval of the pertinent submittal will be at the sole expense and responsibility of Contractor.
- C. Submittal Procedures
 - 1. Before submitting each Shop Drawing or Sample, Contractor shall have determined and verified:
 - a. all field measurements, quantities, dimensions, specified performance and design criteria, installation requirements, materials, catalog numbers, and similar information with respect thereto;
 - b. the suitability of all materials with respect to intended use, fabrication, shipping, handling, storage, assembly, and installation pertaining to the performance of the Work;
 - c. all information relative to Contractor's responsibilities for means, methods, techniques, sequences, and procedures of construction, and safety precautions and programs incident thereto; and
 - d. shall also have reviewed and coordinated each Shop Drawing or Sample with other Shop Drawings and Samples and with the requirements of the Work and the Contract Documents.

2. Each submittal shall bear a stamp or specific written certification that Contractor has satisfied Contractor's obligations under the Contract Documents with respect to Contractor's review and approval of that submittal.
3. With each submittal, Contractor shall give Construction Coordinator specific written notice of any variations, that the Shop Drawing or Sample may have from the requirements of the Contract Documents. This notice shall be both a written communication separated from the Shop Drawing's or Sample Submittal; and, in addition, by a specific notation made on each Shop Drawing or Sample submitted to Construction Coordinator for review and approval of each such variation.

D. Construction Coordinator's Review

1. Construction Coordinator will provide timely review of Shop Drawings and Samples in accordance with the Schedule of Submittals acceptable to Construction Coordinator. Construction Coordinator's review and approval will be only to determine if the items covered by the submittals will, after installation or incorporation in the Work, conform to the information given in the Contract Documents and be compatible with the design concept of the completed Project as a functioning whole as indicated by the Contract Documents.
2. Construction Coordinator's review and approval will not extend to means, methods, techniques, sequences, or procedures of construction (except where a particular means, method, technique, sequence, or procedure of construction is specifically and expressly called for by the Contract Documents) or to safety precautions or programs incident thereto. The review and approval of a separate item as such will not indicate approval of the assembly in which the item functions.
3. Construction Coordinator's review and approval shall not relieve Contractor from responsibility for any variation from the requirements of the Contract Documents unless Contractor has complied with the requirements of Paragraph 6.17.C.3 and Construction Coordinator has given written approval of each such variation by specific written notation thereof incorporated in or accompanying the Shop Drawing or Sample. Construction Coordinator's review and approval shall not relieve Contractor from responsibility for complying with the requirements of Paragraph 6.17.C 1.

E. Resubmittal Procedures

1. Contractor shall make corrections required by Construction Coordinator and shall return the required number of corrected copies of Shop Drawings and submit, as required, new Samples for review and approval. Contractor shall direct specific attention in writing to revisions other than the corrections called for by the Construction Coordinator on previous submittals.
- F.** Contractor shall furnish required submittals with sufficient information and accuracy in order to obtain required approval of an item with no more than three (3) submittals. Construction Coordinator will record the Architect or Engineer's time for reviewing subsequent submittals of Shop Drawings, samples or other items requiring approval and Contractor shall reimburse Owner for the Architect or Engineer's charges for such time.
- G.** In the event that Contractor requests a substitution for a previously approved item, Contractor shall reimburse Owner for the Architect or Engineer's charges for such time unless the need for such substitution is beyond the control of Contractor.

6.18 Continuing the Work

- A.** Contractor shall carry on the Work and adhere to the Progress Schedule during all disputes or disagreements with Owner. No Work shall be delayed or postponed pending resolution of any

disputes or disagreements, except as permitted by Paragraph 15.04 or as Owner and Contractor may otherwise agree in writing.

6.19 Contractor's General Warranty and Guarantee

- A. Contractor warrants and guarantees to Owner that all Work will be in accordance with the Contract Documents and will not be defective. Construction Coordinator and its Related Entities shall be entitled to rely on representation of Contractor's warranty and guarantee.
- B. Contractor's warranty and guarantee hereunder excludes defects or damage caused by:
 - 1. abuse, modification, or improper maintenance or operation by persons other than Contractor, Subcontractors, Suppliers, or any other individual or entity for whom Contractor is responsible; or
 - 2. normal wear and tear under normal usage.
- C. Contractor's obligation to perform and complete the Work in accordance with the Contract Documents shall be absolute. None of the following will constitute an acceptance of Work that is not in accordance with the Contract Documents or a release of Contractor's obligation to perform the Work in accordance with the Contract Documents:
 - 1. observations by Construction Coordinator;
 - 2. recommendation by Construction Coordinator or payment by Owner of any progress or final payment;
 - 3. the issuance of a certificate of Substantial Completion by Construction Coordinator or any payment related thereto by Owner;
 - 4. use or occupancy of the Work or any part thereof by Owner;
 - 5. any review and approval of a Shop Drawing or Sample submittal or the issuance of a notice of acceptability by Construction Coordinator;
 - 6. any inspection, test, or approval by others; or
 - 7. any correction of defective Work by Owner.
- D. The Contractor's General Warranty and Guarantee shall be for a period of one (1) year after work has been accepted and final payment made to the Contractor. In the case of Water and Wastewater lines, the warranty period will start after acceptance of these lines into the utility provider's system for ownership, operation, and maintenance. The Contractor accepts the transference of all warranties and guarantees to the utility provider owning and operating the new lines.

6.20 Indemnification

- A. To the fullest extent permitted by Laws and Regulations, Contractor shall indemnify and hold harmless Owner and Construction Coordinator, and the officers, directors, partners, employees, agents, consultants and subcontractors of each and any of them from and against all claims, costs, losses, and damages (including but not limited to all fees and charges of engineers, architects, attorneys, and other professionals and all court or arbitration or other dispute resolution costs) arising out of or relating to the performance of the Work, provided that any such claim, cost, loss, or damage is attributable to bodily injury, sickness, disease, or death, or to injury to or destruction of tangible property (other than the Work itself), including the loss of use resulting therefrom but only to the extent caused by any negligent act or

omission of Contractor, any Subcontractor, any Supplier, or any individual or entity directly or indirectly employed by any of them to perform any of the Work or anyone for whose acts any of them may be liable .

- B. In any and all claims against Owner or Construction Coordinator or any of their respective consultants, agents, officers, directors, partners, or employees by any employee (or the survivor or personal representative of such employee) of Contractor, any Subcontractor, any Supplier, or any individual or entity directly or indirectly employed by any of them to perform any of the Work, or anyone for whose acts any of them may be liable, the indemnification obligation under Paragraph 6.20.A shall not be limited in any way by any limitation on the amount or type of damages, compensation, or benefits payable by or for Contractor or any such Subcontractor, Supplier, or other individual or entity under workers' compensation acts, disability benefit acts, or other employee benefit acts.
- C. The indemnification obligations of Contractor under Paragraph 6.20.A shall not extend to the liability of Construction Coordinator and Construction Coordinator's officers, directors, partners, employees, agents, consultants and subcontractors arising out of:
 - 1. the preparation or approval of, or the failure to prepare or approve, maps, Drawings, opinions, reports, surveys, Change Orders, designs, or Specifications; or
 - 2. giving directions or instructions, or failing to give them, if that is the primary cause of the injury or damage.

6.21 Delegation of Professional Design Services

- A. Contractor will not be required to provide professional design services unless such services are specifically required by the Contract Documents for a portion of the Work or unless such services are required to carry out Contractor's responsibilities for construction means, methods, techniques, sequences and procedures. Contractor shall not be required to provide professional services in violation of applicable law.
- B. If professional design services or certifications by a design professional related to systems, materials or equipment are specifically required of Contractor by the Contract Documents, Owner and Construction Coordinator will specify all performance and design criteria that such services must satisfy. Contractor shall cause such services or certifications to be provided by a properly licensed professional, whose signature and seal shall appear on all drawings, calculations, specifications, certifications, Shop Drawings and other submittals prepared by such professional. Shop Drawings and other submittals related to the Work designed or certified by such professional, if prepared by others, shall bear such professional's written approval when submitted to Construction Coordinator.
- C. Owner and Construction Coordinator shall be entitled to rely upon the adequacy, accuracy and completeness of the services, certifications or approvals performed by such design professionals, provided Owner and Construction Coordinator have specified to Contractor all performance and design criteria that such services must satisfy.
- D. Pursuant to this Paragraph 6.21, Construction Coordinator's review and approval of design calculations and design drawings will be only for the limited purpose of checking for conformance with performance and design criteria given and the design concept expressed in the Contract Documents. Construction Coordinator's review and approval of Shop Drawings and other submittals (except design calculations and design drawings) will be only for the purpose stated in Paragraph 6.17.D 1.
- E. Contractor shall not be responsible for the adequacy of the performance or design criteria required by the Contract Documents.

PART 7 - OTHER WORK AT THE SITE

7.01 Related Work at Site

- A. Owner may perform other work related to the Project at the Site with Owner's employees or via other direct contracts therefor, or have other work performed by utility owners. If such other work is not noted in the Contract Documents.
- B. Contractor shall afford each other contractor who is a party to such a direct contract, each utility owner and Owner, if Owner is performing other work with Owner's employees, proper and safe access to the Site, a reasonable opportunity for the introduction and storage of materials and equipment and the execution of such other work, and shall properly coordinate the Work with theirs. Contractor shall do all cutting, fitting, and patching of the Work that may be required to properly connect or otherwise make its several parts come together and properly integrate with such other work. Contractor shall not endanger any work of others by cutting, excavating, or otherwise altering their work and will only cut or alter their work with the written consent of Construction Coordinator and the others whose work will be affected. The duties and responsibilities of Contractor under this Paragraph are for the benefit of such utility owners and other contractors to the extent that there are comparable provisions for the benefit of Contractor in said direct contracts between Owner and such utility owners and other contractors.
- C. If the proper execution or results of any part of Contractor's Work depends upon work performed by others under this Part 7, Contractor shall inspect such other work and promptly report to Construction Coordinator in writing any delays, defects, or deficiencies in such other work that render it unavailable or unsuitable for the proper execution and results of Contractor's Work. Contractor's failure to so report will constitute an acceptance of such other work as fit and proper for integration with Contractor's Work except for latent defects and deficiencies in such other work.

7.02 Coordination

- A. If Owner intends to contract with others for the performance of other work on the Project at the Site, the following will be set forth:
 - 1. the individual or entity who will have authority and responsibility for coordination of the activities among the various contractors will be identified;
 - 2. the specific matters to be covered by such authority and responsibility will be itemized; and
 - 3. the extent of such authority and responsibilities will be provided.
- B. Owner shall have sole authority and responsibility for such coordination.

7.03 Legal Relationships

- A. Paragraphs 7.01.A and 7.02 are not applicable for utilities not under the control of Owner.
- B. Each other direct contract of Owner under Paragraph 7.01.A shall provide that the other contractor is liable to Owner and Contractor for the reasonable direct delay and disruption costs incurred by Contractor as a result of the other contractor's actions or inactions.
- C. Contractor shall be liable to Owner and any other contractor for the reasonable direct delay and disruption costs incurred by such other contractor as a result of Contractor's action or inactions.

7.04 Claims Between Contractors

- A. Should Contractor cause damage to the work or property of any other contractor at the Site, or should any claim arising out of Contractor's performance of the Work at the Site be made by any other contractor against Contractor, Owner, Construction Coordinator, or Contractor shall promptly attempt to settle with such other contractor by agreement, or to otherwise resolve the dispute by arbitration or at law.
- B. Contractor shall, to the fullest extent permitted by Laws and Regulations, indemnify and hold harmless Owner, the Construction Coordinator and the officers, directors, partners, employees, agents and other consultants and subcontractors of each and any of them from and against all claims, costs, losses and damages (including, but not limited to, fees and charges of engineers, architects, attorneys, and other professionals and court and arbitration costs) arising directly, indirectly or consequentially out of any action, legal or equitable, brought by any other contractor against Owner, Construction Coordinator, Construction Coordinator's Consultants to the extent said claim is based on or arises out of Contractor's performance of the Work. Should another contractor cause damage to the Work or property of Contractor or should the performance of work by any other contractor at the Site give rise to any other Claim, Contractor shall not institute any action, legal or equitable, against Owner, or the Construction Coordinator or permit any action against any of them to be maintained and continued in its name or for its benefit in any court or before any arbiter which seeks to impose liability on or to recover damages from Owner, or the Construction Coordinator on account of any such damage or Claim.
- C. If Contractor is delayed at any time in performing or furnishing Work by any act or neglect of another contractor, and Owner and Contractor are unable to agree as to the extent of any adjustment in Contract Times attributable thereto, Contractor may make a Claim for an extension of times in accordance with Part 12. An extension of the Contract Times shall be Contractor's exclusive remedy with respect to Owner, and construction coordinator for any delay, disruption, interference, or hindrance caused by any other contractor. This paragraph does not prevent recovery from Owner, or construction coordinator for activities that are their respective responsibilities.

PART 8 - OWNER'S RESPONSIBILITIES

8.01 Communications to Contractor

- A. Except as otherwise provided in these General Conditions, Owner shall issue all communications to Contractor through the Construction Coordinator.

8.02 Replacement of Construction Coordinator

- A. In case of termination of the employment of the Construction Coordinator, Owner shall appoint a Construction Coordinator to whose status under the Contract Documents shall be that of the former Construction Coordinator.

8.03 Furnish Data

- A. Owner shall promptly furnish the data required of Owner under the Contract Documents.

8.04 Pay When Due

- A. Owner shall make payments to Contractor when they are due as provided in Paragraphs 14.02.C and 14.07.C.

8.05 Lands and Easements; Reports and Tests

- A. Owner's duties in respect of providing lands and easements and providing engineering surveys to establish reference points are set forth in Paragraphs 4.01 and 4.05. Paragraph 4.02 refers to Owner's identifying and making available to Contractor copies of reports of explorations and

tests of subsurface conditions and drawings of physical conditions in or relating to existing surface or subsurface structures at or contiguous to the Site that have been utilized by the Architect or Engineer in preparing the Contract Documents.

8.06 Insurance

- A. Owner's responsibilities, if any, in respect to purchasing and maintaining liability and property insurance are set forth in Part 5.

8.07 Change Orders

- A. Owner is obligated to execute Change Orders as indicated in Paragraph 10.03.

8.08 Inspections, Tests, and Approvals

- A. Owner's responsibility in respect to certain inspections, tests, and approvals is set forth in Paragraph 13.03.B.

8.09 Limitations on Owner's Responsibilities

- A. The Owner shall not supervise, direct, or have control or authority over, nor be responsible for, Contractor's means, methods, techniques, sequences, or procedures of construction, or the safety precautions and programs incident thereto, or for any failure of Contractor to comply with Laws and Regulations applicable to the performance of the Work. Owner will not be responsible for Contractor's failure to perform the Work in accordance with the Contract Documents.

8.10 Undisclosed Hazardous Environmental Condition

- A. Owner's responsibility in respect to an undisclosed Hazardous Environmental Condition is set forth in Paragraph 4.06.

8.11 Evidence of Financial Arrangements

- A. If and to the extent Owner has agreed to furnish Contractor reasonable evidence that financial arrangements have been made to satisfy Owner's obligations under the Contract Documents, Owner's responsibility in respect thereof will be as set forth.

PART 9 - Construction Coordinator's STATUS DURING CONSTRUCTION

9.01 Owner's Representative

- A. Construction Coordinator will be Owner's representative during the construction period. The duties and responsibilities and the limitations of authority of Construction Coordinator as Owner's representative during construction are set forth in the Contract Documents and will not be changed without written consent of Owner and Construction Coordinator.

9.02 Visits to Site

- A. Construction Coordinator will make visits to the Site at intervals appropriate to the various stages of construction as Engineer deems necessary in order to observe as an experienced and qualified design professional the progress that has been made and the quality of the various aspects of Contractor's executed Work. Based on information obtained during such visits and observations, Construction Coordinator, for the benefit of Owner, will determine, in general, if the Work is proceeding in accordance with the Contract Documents. Construction Coordinator will not be required to make exhaustive or continuous inspections on the Site to check the quality or quantity of the Work. Construction Coordinator's efforts will be directed

toward providing for Owner a greater degree of confidence that the completed Work will conform generally to the Contract Documents. On the basis of such visits and observations, Construction Coordinator will keep Owner informed of the progress of the Work and will endeavor to guard Owner against defective Work.

- B. Construction Coordinator's visits and observations are subject to all the limitations on Construction Coordinator's authority and responsibility set forth in Paragraph 9.09. Particularly, but without limitation, during or as a result of Construction Coordinator's visits or observations of Contractor's Work Construction Coordinator will not supervise, direct, control, or have authority over or be responsible for Contractor's means, methods, techniques, sequences, or procedures of construction, or the safety precautions and programs incident thereto, or for any failure of Contractor to comply with Laws and Regulations applicable to the performance of the Work.

9.03 Project Representative

- A. If Owner and Construction Coordinator agree; Construction Coordinator will furnish a Resident Project Representative to assist Construction Coordinator in providing more extensive observation of the Work. The authority and responsibilities of any such Resident Project Representative and assistants will be as provided, and limitations on the responsibilities thereof will be as provided in Paragraph 9.09. If Owner designates another representative or agent to represent Owner at the Site who is not Construction Coordinator's consultant, agent or employee, the responsibilities and authority and limitations thereon of such other individual or entity will be as provided in Paragraph 9.09.

9.04 Authorized Variations in Work

- A. Construction Coordinator may authorize minor variations in the Work from the requirements of the Contract Documents which do not involve an adjustment in the Contract Price or the Contract Times and are compatible with the design concept of the completed Project as a functioning whole as indicated by the Contract Documents. These may be accomplished by a Field Order and will be binding on Owner and also on Contractor, who shall perform the Work involved promptly. If Owner or Contractor believes that a Field Order justifies an adjustment in the Contract Price or Contract Times, or both, and the parties are unable to agree on entitlement to or on the amount or extent, if any, of any such adjustment, a Claim may be made therefor as provided in Paragraph 10.05.

9.05 Rejecting Defective Work

- A. Construction Coordinator will have authority to reject Work, which Construction Coordinator believes to be defective, or that Construction Coordinator believes will not produce a completed Project that conforms to the Contract Documents or that will prejudice the integrity of the design concept of the completed Project as a functioning whole as indicated by the Contract Documents. Construction Coordinator will also have authority to require special inspection or testing of the Work as provided in Paragraph 13.04, whether or not the Work is fabricated, installed, or completed.

9.06 Shop Drawings, Change Orders and Payments

- A. In connection with Construction Coordinator's authority, and limitations thereof, as to Shop Drawings and Samples, see Paragraph 6.17.
- B. In connection with Construction Coordinator's authority, and limitations thereof, as to design calculations and design drawings submitted in response to a delegation of professional design services, if any, see Paragraph 6.21.

- C. In connection with Construction Coordinator's authority as to Change Orders, see Parts 10, 11, and 12.
- D. In connection with Construction Coordinator's authority as to Applications for Payment, see Part 14.

9.07 Determinations for Unit Price Work

- A. Construction Coordinator will determine the actual quantities and classifications of Unit Price Work performed by Contractor. Construction Coordinator will review with Contractor the Construction Coordinator's preliminary determinations on such matters before rendering a written decision thereon (by recommendation of an Application for Payment or otherwise). Construction Coordinator's written decision thereon will be final and binding (except as modified by Construction Coordinator to reflect changed factual conditions or more accurate data) upon Owner and Contractor, subject to the provisions of Paragraph 10.05.

9.08 Decisions on Requirements of Contract Documents and Acceptability of Work

- A. Construction Coordinator will be the initial interpreter of the requirements of the Contract Documents and judge of the acceptability of the Work thereunder. All matters in question and other matters between Owner and Contractor arising prior to the date final payment is due relating to the acceptability of the Work, and the interpretation of the requirements of the Contract Documents pertaining to the performance of the Work, will be referred initially to the Construction Coordinator in writing within 30 days of the event giving rise to the question
- B. Construction Coordinator will, with reasonable promptness, render a written decision on the issue referred. If Owner or Contractor believe that any such decision entitles them to an adjustment in the Contract Price or Contract Times or both, a Claim may be made under Paragraph 10.05. The date of Construction Coordinator's decision shall be the date of the event giving rise to the issues referenced for the purposes of Paragraph 10.05.B.
- C. Construction Coordinator's written decision on the issue referred will be final and binding on Owner and Contractor, subject to the provisions of Paragraph 10.05.
- D. When functioning as interpreter and judge under this Paragraph 9.08, Construction Coordinator will not show partiality to Owner or Contractor and will not be liable in connection with any interpretation or decision rendered in good faith in such capacity.

9.09 Limitations on Construction Coordinator's Authority and Responsibilities

- A. Neither Construction Coordinator's authority or responsibility under this Part 9 or under any other provision of the Contract Documents nor any decision made by Construction Coordinator in good faith either to exercise or not exercise such authority or responsibility or the undertaking, exercise, or performance of any authority or responsibility by Construction Coordinator shall create, impose, or give rise to any duty in contract, tort, or otherwise owed by Construction Coordinator to Contractor, any Subcontractor, any Supplier, any other individual or entity, or to any surety for or employee or agent of any of them.
- B. Construction Coordinator will not supervise, direct, control, or have authority over or be responsible for Contractor's means, methods, techniques, sequences, or procedures of construction, or the safety precautions and programs incident thereto, or for any failure of Contractor to comply with Laws and Regulations applicable to the performance of the Work. Construction Coordinator will not be responsible for Contractor's failure to perform the Work in accordance with the Contract Documents.
- C. Construction Coordinator will not be responsible for the acts or omissions of Contractor or of any Subcontractor, any Supplier, or of any other individual or entity performing any of the Work.

- D. Construction Coordinator's review of the final Application for Payment and accompanying documentation and all maintenance and operating instructions, schedules, guarantees, bonds, certificates of inspection, tests and approvals, and other documentation required to be delivered by Paragraph 14.07.A will only be to determine generally that their content complies with the requirements of, and in the case of certificates of inspections, tests, and approvals that the results certified indicate compliance with the Contract Documents.
- E. The limitations upon authority and responsibility set forth in this Paragraph 9.09 shall also apply to, the Resident Project Representative, if any, and assistants, if any.

PART 10 - CHANGES IN THE WORK; CLAIMS

10.01 Authorized Changes in the Work

- A. Without invalidating the Contract and without notice to any surety, Owner may, at any time or from time to time, order additions, deletions, or revisions in the Work by a Change Order, or a Work Change Directive. Upon receipt of any such document, Contractor shall promptly proceed with the Work involved which will be performed under the applicable conditions of the Contract Documents (except as otherwise specifically provided).
- B. If Owner and Contractor are unable to agree on entitlement to, or on the amount or extent, if any, of an adjustment in the Contract Price or Contract Times, or both, that should be allowed as a result of a Work Change Directive, a Claim may be made therefor as provided in Paragraph 10.05.

10.02 Unauthorized Changes in the Work

- A. Contractor shall not be entitled to an increase in the Contract Price or an extension of the Contract Times with respect to any work performed that is not required by the Contract Documents as amended, modified, or supplemented as provided in Paragraph 3.04, except in the case of an emergency as provided in Paragraph 6.16 or in the case of uncovering Work as provided in Paragraph 13.04.B.

10.03 Execution of Change Orders

- A. Owner and Contractor shall execute appropriate Change Orders recommended by Construction Coordinator covering:
 - 1. changes in the Work which are: (i) ordered by Owner pursuant to Paragraph 10.01.A, required because of acceptance of defective Work under Paragraph 13.08.A or Owner's correction of defective Work under Paragraph 13.09, or (iii) agreed to by the parties;
 - 2. changes in the Contract Price or Contract Times which are agreed to by the parties, including any undisputed sum or amount of time for Work actually performed in accordance with a Work Change Directive; and
 - 3. changes in the Contract Price or Contract Times which embody the substance of any written decision rendered by Construction Coordinator pursuant to Paragraph 10.05; provided that, in lieu of executing any such Change Order, an appeal may be taken from any such decision in accordance with the provisions of the Contract Documents and applicable Laws and Regulations, but during any such appeal, Contractor shall carry on the Work and adhere to the Progress Schedule as provided in Paragraph 6.18.A.

10.04 Notification to Surety

- A. If notice of any change affecting the general scope of the Work or the provisions of the Contract Documents (including, but not limited to, Contract Price or Contract Times and Warranty Requirements) is required by the provisions of any bond to be given to a surety, the giving of any such notice will be Contractor's responsibility. The amount of each applicable bond will be adjusted to reflect the effect of any such change.

10.05 Claims

- A. Construction Coordinator's Decision Required: All Claims, except those waived pursuant to Paragraph 14.09, shall be referred to the Construction Coordinator for decision. A decision by Construction Coordinator shall be required as a condition precedent to any exercise by Owner or Contractor of any rights or remedies either may otherwise have under the Contract Documents or by Laws and Regulations in respect of such Claims.
- B. Notice: Written notice stating the general nature of each Claim shall be delivered by the claimant to Construction Coordinator and the other party to the Contract promptly (but in no event, later than 30 days) after the start of the event giving rise thereto. The responsibility to substantiate a Claim shall rest with the party making the Claim. Notice of the amount or extent of the Claim, with supporting data shall be delivered to the Construction Coordinator and the other party to the Contract within 60 days after the start of such event (unless Construction Coordinator allows additional time for claimant to submit additional or more accurate data in support of such Claim). A Claim for an adjustment in Contract Price shall be prepared in accordance with the provisions of Paragraph 12.01.B. A Claim for an adjustment in Contract Time shall be prepared in accordance with the provisions of Paragraph 12.02.B. Each Claim shall be accompanied by claimant's written statement that the adjustment claimed is the entire adjustment to which the claimant believes it is entitled as a result of said event. The opposing party shall submit any response to Construction Coordinator and the claimant within 30 days after receipt of the claimant's last submittal (unless Construction Coordinator allows additional time).
- C. Construction Coordinator's Action: Construction Coordinator will review each Claim and, within 30 days after receipt of the last submittal of the claimant or the last submittal of the opposing party, if any, take one of the following actions in writing:
 - 1. deny the Claim in whole or in part,
 - 2. approve the Claim, or
 - 3. notify the parties that the Construction Coordinator is unable to resolve the Claim if, in the Construction Coordinator's sole discretion, it would be inappropriate for the Construction Coordinator to do so. For purposes of further resolution of the Claim, such notice shall be deemed a denial.
- D. In the event that Construction Coordinator does not take action on a Claim within said 30 days, the Claim shall be deemed denied.
- E. Non-withstanding anything herein final approval rests with the Owner.
- F. No Claim for an adjustment in Contract Price or Contract Times will be valid if not submitted in accordance with this Paragraph 10.05.

PART 11 - COST OF THE WORK; ALLOWANCES; UNIT PRICE WORK

11.01 Cost of the Work

- A. Costs Included: The term Cost of the Work means the sum of all costs, except those excluded in Paragraph 11.01.B, necessarily incurred and paid by Contractor in the proper performance of the Work. When the value of any Work covered by a Change Order or when a Claim for an adjustment in Contract Price is determined on the basis of Cost of the Work, the costs to be reimbursed to Contractor will be only those additional or incremental costs required because of the change in the Work or because of the event giving rise to the Claim. Except as otherwise may be agreed to in writing by Owner, such costs shall be in amounts no higher than those prevailing in the locality of the Project, shall include only the following items, and shall not include any of the costs itemized in Paragraph 11.01.B.
1. Payroll costs for employees in the direct employ of Contractor in the performance of the Work under schedules of job classifications agreed upon by Owner and Contractor. Such employees shall include, without limitation, superintendents, foremen, and other personnel employed full time at the Site. Payroll costs for employees not employed full time on the Work shall be apportioned on the basis of their time spent on the Work. Payroll costs shall include, but not be limited to, salaries and wages plus the cost of fringe benefits, which shall include social security contributions, unemployment, excise, and payroll taxes, workers' compensation, health and retirement benefits, bonuses, sick leave, vacation and holiday pay applicable thereto. The expenses of performing Work outside of regular working hours, on Saturday, Sunday, or legal holidays, shall be included in the above to the extent authorized by Owner.
 2. Cost of all materials and equipment furnished and incorporated in the Work, including costs of transportation and storage thereof, and Suppliers' field services required in connection therewith. All cash discounts shall accrue to Contractor unless Owner deposits funds with Contractor with which to make payments, in which case the cash discounts shall accrue to Owner. All trade discounts, rebates and refunds and returns from sale of surplus materials and equipment shall accrue to Owner, and Contractor shall make provisions so that they may be obtained.
 3. Payments made by Contractor to Subcontractors for Work performed by Subcontractors. If required by Owner, Contractor shall obtain competitive bids from subcontractors acceptable to Owner and Contractor and shall deliver such bids to Owner, who will then determine, with the advice of Construction Coordinator, which bids, if any, will be acceptable. If any subcontract provides that the Subcontractor is to be paid on the basis of Cost of the Work plus a fee, the Subcontractor's Cost of the Work and fee shall be determined in the same manner as Contractor's Cost of the Work and fee as provided in this Paragraph 11.01.
 4. Costs of special consultants (including but not limited to Engineers, Architects, testing laboratories, surveyors, attorneys, and accountants) employed for services specifically related to the Work.
 5. Supplemental costs including the following:
 - a. The proportion of necessary transportation, travel, and subsistence expenses of Contractor's employees incurred in discharge of duties connected with the Work.
 - b. Cost, including transportation and maintenance, of all materials, supplies, equipment, machinery, appliances, office, and temporary facilities at the Site, and hand tools not owned by the workers, which are consumed in the performance of the Work, and cost, less market value, of such items used but not consumed which remain the property of Contractor.
 - c. Rentals of all construction equipment and machinery, and the parts thereof whether rented from Contractor or others in accordance with rental agreements approved by Owner with the advice of Construction Coordinator, and the costs of transportation,

loading, unloading, assembly, dismantling, and removal thereof. All such costs shall be in accordance with the terms of said rental agreements. The rental of any such equipment, machinery, or parts shall cease when the use thereof is no longer necessary for the Work.

- d. Sales, consumer, use, and other similar taxes related to the Work, and for which Contractor is liable, imposed by Laws and Regulations.
- e. Deposits lost for causes other than negligence of Contractor, any Subcontractor, or anyone directly or indirectly employed by any of them or for whose acts any of them may be liable, and royalty payments and fees for permits and licenses.
- f. Losses and damages (and related expenses) caused by damage to the Work, not compensated by insurance or otherwise, sustained by Contractor in connection with the performance of the Work (except losses and damages within the deductible amounts of property insurance established in accordance with Paragraph 5.06.D), provided such losses and damages have resulted from causes other than the negligence of Contractor, any Subcontractor, or anyone directly or indirectly employed by any of them or for whose acts any of them may be liable. Such losses shall include settlements made with the written consent and approval of Owner. No such losses, damages, and expenses shall be included in the Cost of the Work for the purpose of determining Contractor's fee.
- g. The cost of utilities, fuel, and sanitary facilities at the Site.
- h. Minor expenses such as telegrams, long distance telephone calls, telephone service at the Site, expresses, and similar petty cash items in connection with the Work.
- i. The costs of premiums for all bonds and insurance Contractor is required by the Contract Documents to purchase and maintain.

B. Costs Excluded: The term Cost of the Work shall not include any of the following items:

- 1. Payroll costs and other compensation of Contractor's officers, executives, principals (of partnerships and sole proprietorships), general managers, safety managers, engineers, architects, estimators, attorneys, auditors, accountants, purchasing and contracting agents, expeditors, timekeepers, clerks, and other personnel employed by Contractor, whether at the Site or in Contractor's principal or branch office for general administration of the Work and not specifically included in the agreed upon schedule of job classifications referred to in Paragraph 11.01.A.1 or specifically covered by Paragraph 11.01.A.4, all of which are to be considered administrative costs covered by the Contractor's fee.
- 2. Expenses of Contractor's principal and branch offices other than Contractor's office at the Site.
- 3. Any part of Contractor's capital expenses, including interest on Contractor's capital employed for the Work and charges against Contractor for delinquent payments.
- 4. Costs due to the negligence of Contractor, any Subcontractor, or anyone directly or indirectly employed by any of them or for whose acts any of them may be liable, including but not limited to, the correction of defective Work, disposal of materials or equipment wrongfully supplied, and making good any damage to property.
- 5. Other overhead or general expense costs of any kind and the costs of any item not specifically and expressly included in Paragraphs 11.01.A and 11.01.B.

- C. Contractor's Fee: When all the Work is performed on the basis of cost-plus, Contractor's fee shall be determined as set forth in the Agreement. When the value of any Work covered by a Change Order or when a Claim for an adjustment in Contract Price is determined on the basis of Cost of the Work, Contractor's fee shall be determined as set forth in Paragraph 12.01.C.
- D. Documentation: Whenever the Cost of the Work for any purpose is to be determined pursuant to Paragraphs 11.01.A and 11.01.B, Contractor will establish and maintain records thereof in accordance with generally accepted accounting practices and submit in a form acceptable to Engineer an itemized cost breakdown together with supporting data.

11.02 Allowances

- A. It is understood that Contractor has included in the Contract Price all allowances so named in the Contract Documents and shall cause the Work so covered to be performed for such sums and by such persons or entities as may be acceptable to Owner and Construction Coordinator.
- B. Cash Allowances
 - 1. Contractor agrees that:
 - a. the cash allowances include the cost to Contractor (less any applicable trade discounts) of materials and equipment required by the allowances to be delivered at the Site, and all applicable taxes; and
 - b. Contractor's costs for unloading and handling on the Site, labor, installation, overhead, profit, and other expenses contemplated for the cash allowances have been included in the Contract Price and not in the allowances, and no demand for additional payment on account of any of the foregoing will be valid.
- C. Contingency Allowance
 - 1. Contractor agrees that a contingency allowance, if any, is for the sole use of Owner to cover unanticipated costs.
- D. Prior to final payment, an appropriate Change Order will be issued as recommended by Construction Coordinator to reflect actual amounts due Contractor on account of Work covered by allowances, and the Contract Price shall be correspondingly adjusted.

11.03 Unit Price Work

- A. Initially the Contract Price will be deemed to include for all Unit Price Work an amount equal to the sum of the unit price for each separately identified item of Unit Price Work times the estimated quantity of each item as indicated in the Agreement.
- B. The estimated quantities of items of Unit Price Work are not guaranteed and are solely for the purpose of comparison of Bids and determining an initial Contract Price. Determinations of the actual quantities and classifications of Unit Price Work performed by Contractor will be made by the Owner subject to the provisions of Paragraph 9.07.
- C. Each unit price will be deemed to include an amount considered by Contractor to be adequate to cover Contractor's overhead and profit for each separately identified item.
- D. Owner or Contractor may make a Claim for an adjustment in the Contract Price in accordance with Paragraph 10.05 if:

1. the quantity of any item of Unit Price Work performed by Contractor differs materially and significantly from the estimated quantity of such item indicated in the Agreement; and
2. there is no corresponding adjustment with respect any other item of Work; and
3. Contractor believes that Contractor is entitled to an increase in Contract Price as a result of having incurred additional expense or Owner believes that Owner is entitled to a decrease in Contract Price and the parties are unable to agree as to the amount of any such increase or decrease.

PART 12 - CHANGE OF CONTRACT PRICE; CHANGE OF CONTRACT TIMES

12.01 Change of Contract Price

- A. The Contract Price may only be changed by a Change Order. Any Claim for an adjustment in the Contract Price shall be based on written notice submitted by the party making the Claim to the Construction Coordinator and the other party to the Contract in accordance with the provisions of Paragraph 10.05. Final approval of all change orders rests with the owner.
- B. The value of any Work covered by a Change Order or of any Claim for an adjustment in the Contract Price will be determined as follows:
 1. where the Work involved is covered by unit prices contained in the Contract Documents, by application of such unit prices to the quantities of the items involved (subject to the provisions of Paragraph 11.03); or
 2. where the Work involved is not covered by unit prices contained in the Contract Documents, by a mutually agreed lump sum (which may include an allowance for overhead and profit not necessarily in accordance with Paragraph 12.01.C.2); or
 3. where the Work involved is not covered by unit prices contained in the Contract Documents and agreement to a lump sum is not reached under Paragraph 12.01.B.2, on the basis of the Cost of the Work (determined as provided in Paragraph 11.01) plus a Contractor's fee for overhead and profit (determined as provided in Paragraph 12.01.C).
- C. Contractor's Fee: The Contractor's fee for overhead and profit shall be determined as follows:
 1. a mutually acceptable fixed fee; or
 2. if a fixed fee is not agreed upon, then a fee based on the following percentages of the various portions of the Cost of the Work:
 - a. for costs incurred under Paragraphs 11.01.A.1 and 11.01.A.2, the Contractor's fee shall be 15 percent;
 - b. for costs incurred under Paragraph 11.01.A.3, the Contractor's fee shall be five percent;
 - c. where one or more tiers of subcontracts are on the basis of Cost of the Work plus a fee and no fixed fee is agreed upon, the intent of Paragraph 12.01.C.2.a is that the Subcontractor who actually performs the Work, at whatever tier, will be paid a fee of 15 percent of the costs incurred by such Subcontractor under Paragraphs 11.01.A.1 and 11.01.A.2 and that any higher tier Subcontractor and Contractor will each be paid a fee of five percent of the amount paid to the next lower tier Subcontractor;
 - d. no fee shall be payable on the basis of costs itemized under Paragraphs 11.01.A.4, 11.01.A.5, and 11.01.B;

- e. the amount of credit to be allowed by Contractor to Owner for any change which results in a net decrease in cost will be the amount of the actual net decrease in cost plus a deduction in Contractor's fee by an amount equal to five percent of such net decrease; and
- f. when both additions and credits are involved in any one change, the adjustment in Contractor's fee shall be computed on the basis of the net change in accordance with Paragraphs 12.01.C.2.a through 12.01.C.2.e, inclusive.

12.02 Change of Contract Times

- A. The Contract Times may only be changed by a Change Order. Any Claim for an adjustment in the Contract Times shall be based on written notice submitted by the party making the Claim to the Construction Coordinator and the other party to the Contract in accordance with the provisions of Paragraph 10.05. Final approval of all change orders rests with the owner.
- B. Any adjustment of the Contract Times covered by a Change Order or any Claim for an adjustment in the Contract Times will be determined in accordance with the provisions of this Part 12.

12.03 Delays

- A. Where Contractor is prevented from completing any part of the Work within the Contract Times due to delay beyond the control of Contractor, the Contract Times will be extended in an amount equal to the time lost due to such delay if a Claim is made therefor as provided in Paragraph 12.02.A. Delays beyond the control of Contractor shall include, but not be limited to, acts or neglect by Owner, acts or neglect of utility owners or other contractors performing other work as contemplated by Part 7, fires, floods, epidemics, abnormal weather conditions, or acts of God.
- B. If Owner, Construction Coordinator, or other contractors or utility owners performing other work for Owner as contemplated by Part 7, or anyone for whom Owner is responsible, delays, disrupts, or interferes with the performance or progress of the Work, then Contractor shall be entitled to an equitable adjustment in the Contract Price or the Contract Times, or both. Contractor's entitlement to an adjustment of the Contract Times is conditioned on such adjustment being essential to Contractor's ability to complete the Work within the Contract Times.
- C. If Contractor is delayed in the performance or progress of the Work by fire, flood, epidemic, abnormal weather conditions, acts of God, acts or failures to act of utility owners not under the control of Owner, or other causes not the fault of and beyond control of Owner and Contractor, then Contractor shall be entitled to an equitable adjustment in Contract Times, if such adjustment is essential to Contractor's ability to complete the Work within the Contract Times. Such an adjustment shall be Contractor's sole and exclusive remedy for the delays described in this Paragraph 12.03.C.
- D. Owner, Construction Coordinator and the Related Entities of each of them shall not be liable to Contractor for any claims, costs, losses, or damages (including but not limited to all fees and charges of Engineers, Architects, Attorneys, and other professionals and all court or arbitration or other dispute resolution costs) sustained by Contractor on or in connection with any other project or anticipated project.
- E. Contractor shall not be entitled to an adjustment in Contract Price or Contract Times for delays within the control of Contractor. Delays attributable to and within the control of a Subcontractor or Supplier shall be deemed to be delays within the control of Contractor.

- F. All claims for delays shall be submitted at the submission of any application for payment or within fifteen (15) days of the event causing the delay. Any claims made after the allowable time shall be denied.

PART 13 - TESTS AND INSPECTIONS; CORRECTION, REMOVAL OR ACCEPTANCE OF DEFECTIVE WORK

13.01 Notice of Defects

- A. Prompt notice of all defective Work of which Owner or Construction Coordinator has actual knowledge will be given to Contractor. All defective Work may be rejected, corrected, or accepted as provided in this Part 13.

13.02 Access to Work

- A. Owner, Construction Coordinator, their consultants and other representatives and personnel of Owner, independent testing laboratories, and governmental agencies with jurisdictional interests will have access to the Site and the Work at reasonable times for their observation, inspecting, and testing. Contractor shall provide them proper and safe conditions for such access and advise them of Contractor's Site safety procedures and programs so that they may comply therewith as applicable.

13.03 Tests and Inspections

- A. Contractor shall give Construction Coordinator timely notice of readiness of the Work for all required inspections, tests, or approvals and shall cooperate with inspection and testing personnel to facilitate required inspections or tests.
- B. Contractor shall employ and pay for the services of an independent testing laboratory to perform all inspections, tests, or approvals required by the Contract Documents.
- C. If Laws or Regulations of any public body having jurisdiction require any Work (or part thereof) specifically to be inspected, tested, or approved by an employee or other representative of such public body, Contractor shall assume full responsibility for arranging and obtaining such inspections, tests, or approvals, pay all costs in connection therewith, and furnish Construction Coordinator the required certificates of inspection or approval.
- D. Contractor shall be responsible for arranging and obtaining and shall pay all costs in connection with any inspections, tests, or approvals required for Owner's and Construction Coordinator's acceptance of materials or equipment to be incorporated in the Work; or acceptance of materials, mix designs, or equipment submitted for approval prior to Contractor's purchase thereof for incorporation in the Work. Such inspections, tests, or approvals shall be performed by third party organizations acceptable to Owner and Construction Coordinator.
- E. If any Work (or the work of others) that is to be inspected, tested, or approved is covered by Contractor without written concurrence of Construction Coordinator, it must, if requested by Construction Coordinator, be uncovered for observation.
- F. Uncovering Work as provided in Paragraph 13.03.E shall be at Contractor's expense unless Contractor has given Construction Coordinator timely notice of Contractor's intention to cover the same and Construction Coordinator has not acted with reasonable promptness in response to such notice.

13.04 Uncovering Work

- A. If any Work is covered contrary to the written request of Construction Coordinator, it must, if requested by Construction Coordinator, be uncovered for Construction Coordinator's observation and replaced at Contractor's expense.
- B. If Construction Coordinator considers it necessary or advisable that covered Work be observed by Construction Coordinator or inspected or tested by others, Contractor, at Construction Coordinator's request, shall uncover, expose, or otherwise make available for observation, inspection, or testing as Construction Coordinator may require, that portion of the Work in question, furnishing all necessary labor, material, and equipment.
- C. If it is found that the uncovered Work is defective, Contractor shall pay all claims, costs, losses, and damages (including but not limited to all fees and charges of Construction Coordinator, Engineers, Architects, Attorneys, and other professionals and all court or arbitration or other dispute resolution costs) arising out of or relating to such uncovering, exposure, observation, inspection, and testing, and of satisfactory replacement or reconstruction (including but not limited to all costs of repair or replacement of work of others); and Owner shall be entitled to an appropriate decrease in the Contract Price. If the parties are unable to agree as to the amount thereof, Owner may make a Claim therefor as provided in Paragraph 10.05.
- D. If, the uncovered Work is not found to be defective, Contractor shall be allowed an increase in the Contract Price or an extension of the Contract Times, or both, directly attributable to such uncovering, exposure, observation, inspection, testing, replacement, and reconstruction. If the parties are unable to agree as to the amount or extent thereof, Contractor may make a Claim therefor as provided in Paragraph 10.05.

13.05 Owner May Stop the Work

- A. If the Work is defective, or Contractor fails to supply sufficient skilled workers or suitable materials or equipment, or fails to perform the Work in such a way that the completed Work will conform to the Contract Documents, Owner may order Contractor to stop the Work, or any portion thereof, until the cause for such order has been eliminated; however, this right of Owner to stop the Work shall not give rise to any duty on the part of Owner to exercise this right for the benefit of Contractor, any Subcontractor, any Supplier, any other individual or entity, or any surety for, or employee or agent of any of them.

13.06 Correction or Removal of Defective Work

- A. Promptly after receipt of notice, Contractor shall correct all defective Work, whether or not fabricated, installed, or completed, or, if the Work has been rejected by Construction Coordinator, remove it from the Project and replace it with Work that is not defective. Contractor shall pay all claims, costs, losses, and damages (including but not limited to all fees and charges of construction coordinator, engineers, architects, attorneys, and other professionals and all court or arbitration or other dispute resolution costs) arising out of or relating to such correction or removal (including but not limited to all costs of repair or replacement of work of others).
- B. When correcting defective Work under the terms of this Paragraph 13.06 or Paragraph 13.07, Contractor shall take no action that would void or otherwise impair Owner's special warranty and guarantee, if any, on said Work.

13.07 Correction Period

- A. If within one year after the date of Substantial Completion (or such longer period of time as may be prescribed by the terms of any applicable special guarantee required by the Contract Documents) or by any specific provision of the Contract Documents, any Work is found to be defective, or if the repair of any damages to the land or areas made available for Contractor's use by Owner or permitted by Laws and Regulations as contemplated in Paragraph 6.11.A is

found to be defective, Contractor shall promptly, without cost to Owner and in accordance with Owner's written instructions:

1. repair such defective land or areas; or
 2. correct such defective Work; or
 3. if the defective Work has been rejected by Owner, remove it from the Project and replace it with Work that is not defective, and
 4. satisfactorily correct or repair or remove and replace any damage to other Work, to the work of others or other land or areas resulting therefrom.
- B. If Contractor does not promptly comply with the terms of Owner's written instructions, or in an emergency where delay would cause serious risk of loss or damage, Owner may have the defective Work corrected or repaired or may have the rejected Work removed and replaced. All claims, costs, losses, and damages (including but not limited to all fees and charges of construction coordinator, engineers, architects, attorneys, and other professionals and all court or arbitration or other dispute resolution costs) arising out of or relating to such correction or repair or such removal and replacement (including but not limited to all costs of repair or replacement of work of others) will be paid by Contractor.
- C. In special circumstances where a particular item of equipment is placed in continuous service before Substantial Completion of all the Work, the correction period for that item may start to run from an earlier date if so provided in the Specifications.
- D. Where defective Work (and damage to other Work resulting therefrom) has been corrected or removed and replaced under this Paragraph 13.07, the correction period hereunder with respect to such Work will be extended for an additional period of one year after such correction or removal and replacement has been satisfactorily completed.
- E. Contractor's obligations under this Paragraph 13.07 are in addition to any other obligation or warranty. The provisions of this Paragraph 13.07 shall not be construed as a substitute for or a waiver of the provisions of any applicable statute of limitation or repose.

13.08 Acceptance of Defective Work

- A. If, instead of requiring correction or removal and replacement of defective Work, Owner (and, prior to Construction Coordinator's recommendation of final payment, Construction Coordinator) prefers to accept it, Owner may do so. Contractor shall pay all claims, costs, losses, and damages (including but not limited to all fees and charges of construction coordinator, engineers, architects, attorneys, and other professionals and all court or arbitration or other dispute resolution costs) attributable to Owner's evaluation of and determination to accept such defective Work (such costs to be approved by Construction Coordinator as to reasonableness) and the diminished value of the Work to the extent not otherwise paid by Contractor pursuant to this sentence. If any such acceptance occurs prior to Construction Coordinator's recommendation of final payment, a Change Order will be issued incorporating the necessary revisions in the Contract Documents with respect to the Work, and Owner shall be entitled to an appropriate decrease in the Contract Price, reflecting the diminished value of Work so accepted. If the parties are unable to agree as to the amount thereof, Owner may make a Claim therefor as provided in Paragraph 10.05. If the acceptance occurs after such recommendation, an appropriate amount will be paid by Contractor to Owner.

13.09 Owner May Correct Defective Work

- A. If Contractor fails within a reasonable time after written notice from Construction Coordinator to correct defective Work or to remove and replace rejected Work as required by Construction Coordinator in accordance with Paragraph 13.06.A, or if Contractor fails to perform the Work in accordance with the Contract Documents, or if Contractor fails to comply with any other provision of the Contract Documents, Owner may, after seven (7) days written notice to Contractor, correct or remedy any such deficiency.
- B. In exercising the rights and remedies under this Paragraph 13.09, Owner shall proceed expeditiously. In connection with such corrective or remedial action, Owner may exclude Contractor from all or part of the Site, take possession of all or part of the Work and suspend Contractor's services related thereto, take possession of Contractor's tools, appliances, construction equipment and machinery at the Site, and incorporate in the Work all materials and equipment stored at the Site or for which Owner has paid Contractor but which are stored elsewhere. Contractor shall allow Owner, Owner's representatives, agents and employees, Owner's other contractors, and Construction Coordinator and Construction Coordinator's consultants access to the Site to enable Owner to exercise the rights and remedies under this Paragraph.
- C. All claims, costs, losses, and damages (including but not limited to all fees and charges of construction coordinator, engineers, architects, attorneys, and other professionals and all court or arbitration or other dispute resolution costs) incurred or sustained by Owner in exercising the rights and remedies under this Paragraph 13.09 will be charged against Contractor, and a Change Order will be issued incorporating the necessary revisions in the Contract Documents with respect to the Work; and Owner shall be entitled to an appropriate decrease in the Contract Price. If the parties are unable to agree as to the amount of the adjustment, Owner may make a Claim therefor as provided in Paragraph 10.05. Such claims, costs, losses and damages will include but not be limited to all costs of repair, or replacement of work of others destroyed or damaged by correction, removal, or replacement of Contractor's defective Work.
- D. Contractor shall not be allowed an extension of the Contract Times because of any delay in the performance of the Work attributable to the exercise by Owner of Owner's rights and remedies under this Paragraph 13.09.

PART 14 - PAYMENTS TO CONTRACTOR AND COMPLETION

14.01 Schedule of Values

- A. The Schedule of Values established as provided in Paragraph 2.07.A will serve as the basis for progress payments and will be incorporated into a form of Application for Payment acceptable to the Construction Coordinator. Progress payments on account of Unit Price Work will be based on the number of units completed.

14.02 Progress Payments

- A. Applications for Payments
 - 1. At least 20 days before the date established in the Agreement for each progress payment (but not more often than once a month), Contractor shall submit to the Construction Coordinator for review an Application for Payment filled out and signed by Contractor covering the Work completed as of the date of the Application and accompanied by such supporting documentation as is required by the Contract Documents. The date of the pay application must be the last day of the month. If payment is requested on the basis of materials and equipment not incorporated in the Work but delivered and suitably stored at the Site or at another location agreed to in writing, the Application for Payment shall also

be accompanied by a bill of sale, invoice, or other documentation warranting that Owner has received the materials and equipment free and clear of all Liens and evidence that the materials and equipment are covered by appropriate property insurance or other arrangements to protect Owner's interest therein, all of which must be satisfactory to Owner.

2. Beginning with the second Application for Payment, each Application shall include an affidavit of Contractor stating that all previous progress payments received on account of the Work have been applied on account to discharge Contractor's legitimate obligations associated with prior Applications for Payment.
3. The amount of retainage with respect to progress payments will be as stipulated in the Agreement.

B. Review of Applications

1. Construction Coordinator will, within fifteen (15) days after receipt of each Application for Payment, either indicate in writing a recommendation of payment and present the Application to Owner or return the Application to Contractor indicating in writing Construction Coordinator's reasons for refusing to recommend payment. In the latter case, Contractor may make the necessary corrections and resubmit the Application.
2. Construction Coordinator's recommendation of any payment requested in an Application for Payment will constitute a representation by Construction Coordinator to Owner, based on Construction Coordinator's observations on the Site of the executed Work as an experienced and qualified design professional and on Construction Coordinator's review of the Application for Payment and the accompanying data and schedules, that to the best of Construction Coordinator's knowledge, information and belief:
 - a. the Work has progressed to the point indicated;
 - b. the quality of the Work is generally in accordance with the Contract Documents (subject to an evaluation of the Work as a functioning whole prior to or upon Substantial Completion, to the results of any subsequent tests called for in the Contract Documents, to a final determination of quantities and classifications for Unit Price Work under Paragraph 9.07, and to any other qualifications stated in the recommendation); and
 - c. the conditions precedent to Contractor's being entitled to such payment appear to have been fulfilled in so far as it is Construction Coordinator's responsibility to observe the Work.
3. By recommending any such payment Construction Coordinator will not thereby be deemed to have represented that:
 - a. inspections made to check the quality or the quantity of the Work as it has been performed have been exhaustive, extended to every aspect of the Work in progress, or involved detailed inspections of the Work beyond the responsibilities specifically assigned to Construction Coordinator in the Contract Documents; or
 - b. that there may not be other matters or issues between the parties that might entitle Contractor to be paid additionally by Owner or entitle Owner to withhold payment to Contractor.

4. Neither Construction Coordinator's review of Contractor's Work for the purposes of recommending payments nor Construction Coordinator's recommendation of any payment, including final payment, will impose responsibility on Construction Coordinator:
 - a. to supervise, direct, or control the Work, or
 - b. for the means, methods, techniques, sequences, or procedures of construction, or the safety precautions and programs incident thereto, or
 - c. for Contractor's failure to comply with Laws and Regulations applicable to Contractor's performance of the Work, or
 - d. to make any examination to ascertain how or for what purposes Contractor has used the moneys paid on account of the Contract Price, or
 - e. to determine that title to any of the Work, materials, or equipment has passed to Owner free and clear of any Liens.
5. Construction Coordinator may refuse to recommend the whole or any part of any payment if, in Construction Coordinator's opinion, it would be incorrect to make the representations to Owner stated in Paragraph 14.02.B 2. Construction Coordinator may also refuse to recommend any such payment or, because of subsequently discovered evidence or the results of subsequent inspections or tests, revise or revoke any such payment recommendation previously made, to such extent as may be necessary in Construction Coordinator's opinion to protect Owner from loss because:
 - a. the Work is defective, or completed Work has been damaged, requiring correction or replacement;
 - b. the Contract Price has been reduced by Change Orders;
 - c. Owner has been required to correct defective Work or complete Work in accordance with Paragraph 13.09; or
 - d. Construction Coordinator has actual knowledge of the occurrence of any of the events enumerated in Paragraph 15.02.A.

C. Payment Becomes Due

1. Fifteen (15) days after presentation of the Application for Payment to Owner with Construction Coordinator's recommendation, the amount recommended will (subject to the provisions of Paragraph 14.02.D) become due, and when due will be paid by Owner to Contractor.

D. Reduction in Payment

1. Owner may refuse to make payment of the full amount recommended by Construction Coordinator because:
 - a. claims have been made against Owner on account of Contractor's performance or furnishing of the Work;
 - b. Liens have been filed in connection with the Work, except where Contractor has delivered a specific bond satisfactory to Owner to secure the satisfaction and discharge of such Liens;

- c. there are other items entitling Owner to a set-off against the amount recommended; or
 - d. Owner has actual knowledge of the occurrence of any of the events enumerated in Paragraphs 14.02.B.5.a through 14.02.B.5.c or Paragraph 15.02.A.
- 2. If Owner refuses to make payment of the full amount recommended by Construction Coordinator, Owner will give Contractor immediate written notice (with a copy to Construction Coordinator) stating the reasons for such action and promptly pay Contractor any amount remaining after deduction of the amount so withheld. Owner shall promptly pay Contractor the amount so withheld, or any adjustment thereto agreed to by Owner and Contractor, when Contractor corrects to Owner's satisfaction the reasons for such action.
 - 3. If it is subsequently determined that Owner's refusal of payment was not justified, the amount wrongfully withheld shall be treated as an amount due as determined by Paragraph 14.02.C 1.

14.03 Contractor's Warranty of Title

- A. Contractor warrants and guarantees that title to all Work, materials, and equipment covered by any Application for Payment, whether incorporated in the Project or not, will pass to Owner no later than the time of payment free and clear of all Liens.

14.04 Substantial Completion

- A. When Contractor considers the entire Work ready for its intended use Contractor shall notify Owner and Construction Coordinator in writing that the entire Work is substantially complete (except for items specifically listed by Contractor as incomplete) and request that Construction Coordinator issue a certificate of Substantial Completion.
- B. Promptly after Contractor's notification, Owner, Contractor, and Construction Coordinator shall make an inspection of the Work to determine the status of completion. If Construction Coordinator does not consider the Work substantially complete, Construction Coordinator will notify Contractor in writing giving the reasons therefor.
- C. If Construction Coordinator considers the Work substantially complete, the Construction Coordinator will deliver to Owner a tentative certificate of Substantial Completion which shall fix the date of Substantial Completion. There shall be attached to the certificate a tentative list of items to be completed or corrected before final payment. Owner shall have seven (7) days after receipt of the tentative certificate during which to make written objection to Construction Coordinator as to any provisions of the certificate or attached list. If, after considering such objections, Construction Coordinator concludes that the Work is not substantially complete, Construction Coordinator will within 14 days after submission of the tentative certificate to Owner notify Contractor in writing, stating the reasons therefor. If, after consideration of Owner's objections, the Construction Coordinator considers the Work substantially complete, the Construction Coordinator will within be said 14 days execute and deliver to Owner and Contractor a definitive certificate of Substantial Completion (with a revised tentative list of items to be completed or corrected) reflecting such changes from the tentative certificate as Construction Coordinator believes justified after consideration of any objections from Owner.
- D. At the time of delivery of the tentative certificate of Substantial Completion, Construction Coordinator will deliver to Owner and Contractor a written recommendation as to division of responsibilities pending final payment between Owner and Contractor with respect to security, operation, safety, and protection of the Work, maintenance, heat, utilities, insurance, and warranties and guarantees. Unless Owner and Contractor agree otherwise in writing and so informs the Construction Coordinator in writing prior to Construction Coordinator's issuing the definitive certificate of Substantial Completion, Construction Coordinator's aforesaid recommendation will be binding on Owner and Contractor until final payment.

- E. Owner shall have the right to exclude Contractor from the Site after the date of Substantial Completion subject to allowing Contractor reasonable access to complete or correct items on the tentative list.

14.05 Partial Utilization

- A. Prior to Substantial Completion of all the Work, Owner may use or occupy any substantially completed part of the Work which has specifically been identified in the Contract Documents, or which Owner, Construction Coordinator, and Contractor agree constitutes a separately functioning and usable part of the Work that can be used by Owner for its intended purpose without significant interference with Contractor's performance of the remainder of the Work, subject to the following conditions.
 - 1. Owner at any time may request Contractor in writing to permit Owner to use or occupy any such part of the Work Which Owner believes to be ready for its intended use and substantially complete. If and when Contractor agrees that such part of the Work is substantially complete, Contractor will certify to Owner and Construction Coordinator that such part of the Work is substantially complete and request Construction Coordinator to issue a certificate of Substantial Completion for that part of the Work.
 - 2. Contractor at any time may notify Owner and Construction Coordinator in writing that Contractor considers any such part of the Work ready for its intended use and substantially complete and request Construction Coordinator to issue a certificate of Substantial Completion for that part of the Work. Said work should have, at a minimum, a temporary Certificate of Occupancy from the authority having jurisdiction.
 - 3. Within a reasonable time after either such request, Owner, Contractor, and Construction Coordinator shall make an inspection of that part of the Work to determine its status of completion. If Construction Coordinator does not consider that part of the Work to be substantially complete, Construction Coordinator will notify Owner and Contractor in writing giving the reasons therefor. If Construction Coordinator considers that part of the Work to be substantially complete, the provisions of Paragraph 14.04 will apply with respect to certification of Substantial Completion of that part of the Work and the division of responsibility in respect thereof and access thereto.
 - 4. No use or occupancy or separate operation of part of the Work may occur prior to compliance with the requirements of Paragraph 5.10 regarding property insurance.

14.06 Final Inspection

- A. Upon written notice from Contractor that the entire Work or an agreed portion thereof is complete, Construction Coordinator will promptly make a final inspection with Owner and Contractor and will notify Contractor in writing of all particulars in which this inspection reveals that the Work is incomplete or defective. Contractor shall immediately take such measures as are necessary to complete such Work or remedy such deficiencies.

14.07 Final Payment

- A. Application for Payment
 - 1. After Contractor has, in the opinion of Construction Coordinator, satisfactorily completed all corrections identified during the final inspection and has delivered, in accordance with the Contract Documents, all maintenance, training and operating instructions, schedules, guarantees, bonds, certificates or other evidence of insurance certificates of inspection, marked-up record documents to include digital as-builds of the project (as provided in

Paragraph 6.12), and other documents, Contractor may make application for final payment following the procedure for progress payments.

2. The final Application for Payment shall be accompanied (except as previously delivered) by:
 - a. all documentation called for in the Contract Documents, including but not limited to the evidence of insurance required by Paragraph 5.04.B.7;
 - b. consent of the surety, if any, to final payment;
 - c. a list of all Claims against Owner that Contractor believes are unsettled; and
 - d. complete and legally effective releases or waivers (satisfactory to Owner) of all Lien rights arising out of or Liens filed in connection with the Work.
3. In lieu of the releases or waivers of Liens specified in Paragraph 14.07.A.2 and as approved by Owner, Contractor may furnish receipts or releases in full and an affidavit of Contractor that: (i) the releases and receipts include all labor, services, material, and equipment for which a Lien could be filed; and (ii) all payrolls, material and equipment bills, and other indebtedness connected with the Work for which Owner or Owner's property might in any way be responsible have been paid or otherwise satisfied. If any Subcontractor or Supplier fails to furnish such a release or receipt in full, Contractor may furnish a bond or other collateral satisfactory to Owner to indemnify Owner against any Lien.

B. Construction Coordinator's Review of Application and Acceptance

1. If, on the basis of Construction Coordinator's observation of the Work during construction and final inspection, and Construction Coordinator's review of the final Application for Payment and accompanying documentation as required by the Contract Documents, Construction Coordinator is satisfied that the Work has been completed and Contractor's other obligations under the Contract Documents have been fulfilled, Construction Coordinator will, within ten (10) days after receipt of the final Application for Payment, indicate in writing Construction Coordinator's recommendation of payment and present the Application for Payment to Owner for payment. At the same time, Construction Coordinator will also give written notice to Owner and Contractor that the Work is acceptable subject to the provisions of Paragraph 14.09. Otherwise, Construction Coordinator will return the Application for Payment to Contractor, indicating in writing the reasons for refusing to recommend final payment, in which case Contractor shall make the necessary corrections and resubmit the Application for Payment.

C. Payment Becomes Due

1. Thirty (30) days after the presentation to Owner of the Application for Payment and accompanying documentation, the amount recommended by Construction Coordinator, less any sum Owner is entitled to set off against Construction Coordinator's recommendation, including but not limited to liquidated damages, will become due and, will be paid by Owner to Contractor.

14.08 Final Completion Delayed

- A. If, through no fault of Contractor, final completion of the Work is significantly delayed, and if Construction Coordinator so confirms, Owner shall, upon receipt of Contractor's final Application for Payment (for Work fully completed and accepted) and recommendation of Construction Coordinator, and without terminating the Contract, make payment of the balance due for that portion of the Work fully completed and accepted. If the remaining balance to be held by Owner for Work not fully completed or corrected is less than the retainage stipulated in

the Agreement, and if bonds have been furnished as required in Paragraph 5.01, the written consent of the surety to the payment of the balance due for that portion of the Work fully completed and accepted shall be submitted by Contractor to the Construction Coordinator with the Application for such payment. Such payment shall be made under the terms and conditions governing final payment, except that it shall not constitute a waiver of Claims.

14.09 Waiver of Claims

- A. The making and acceptance of final payment will constitute:
 - 1. a waiver of all Claims by Owner against Contractor, except Claims arising from unsettled Liens, from defective Work appearing after final inspection pursuant to Paragraph 14.06, from failure to comply with the Contract Documents or the terms of any special guarantees specified therein, or from Contractor's continuing obligations under the Contract Documents; and
 - 2. a waiver of all Claims by Contractor against Owner other than those previously made in accordance with the requirements herein and expressly acknowledged by Owner in writing as still unsettled.

PART 15 - SUSPENSION OF WORK AND TERMINATION

15.01 Owner May Suspend Work

- A. At any time and without cause, Owner may suspend the Work or any portion thereof for a period of not more than 90 consecutive days by notice in writing to Contractor and Construction Coordinator which will fix the date on which Work will be resumed. Contractor shall resume the Work on the date so fixed. Contractor shall be granted an adjustment in the Contract Price or an extension of the Contract Times, or both, directly attributable to any such suspension if Contractor makes a Claim therefor as provided in Paragraph 10.05.

15.02 Owner May Terminate for Cause

- A. The occurrence of any one or more of the following events will justify termination for cause:
 - 1. Contractor's persistent failure to perform the Work in accordance with the Contract Documents (including, but not limited to, failure to supply sufficient skilled workers or suitable materials or equipment or failure to adhere to the Progress Schedule established under Paragraph 2.07 as adjusted from time to time pursuant to Paragraph 6.04);
 - 2. Contractor's disregard of Laws or Regulations of any public body having jurisdiction;
 - 3. Contractor's disregard of the authority of the Construction Coordinator; or
 - 4. Contractor's violation in any substantial way of any provisions of the Contract Documents.
- B. If one or more of the events identified in Paragraph 15.02.A occur, Owner may, after giving Contractor (and surety) seven (7) days written notice of its intent to terminate the services of Contractor:
 - 1. exclude Contractor from the Site, and take possession of the Work and of all Contractor's tools, appliances, construction equipment, and machinery at the Site, and use the same to the full extent they could be used by Contractor (without liability to Contractor for trespass or conversion),

2. incorporate in the Work all materials and equipment stored at the Site or for which Owner has paid Contractor but which are stored elsewhere, and
 3. complete the Work as Owner may deem expedient.
- C. If Owner proceeds as provided in Paragraph 15.02.B, Contractor shall not be entitled to receive any further payment until the Work is completed. If the unpaid balance of the Contract Price exceeds all claims, costs, losses, and damages (including but not limited to all fees and charges of construction coordinator, engineers, architects, attorneys, and other professionals and all court or arbitration or other dispute resolution costs) sustained by Owner arising out of or relating to completing the Work, such excess will be paid to Contractor. If such claims, costs, losses, and damages exceed such unpaid balance, Contractor shall pay the difference to Owner. Such claims, costs, losses, and damages incurred by Owner will be reviewed by the Construction Coordinator as to their reasonableness and, when so approved by the Construction Coordinator, incorporated in a Change Order. When exercising any rights or remedies under this Paragraph Owner shall not be required to obtain the lowest price for the Work performed.
- D. Notwithstanding Paragraphs 15.02.B and 15.02.C, Contractor's services will not be terminated if Contractor begins within seven (7) days of receipt of notice of intent to terminate to correct its failure to perform and proceeds diligently to cure such failure within no more than 30 days of receipt of said notice.
- E. Where Contractor's services have been so terminated by Owner, the termination will not affect any rights or remedies of Owner against Contractor then existing or which may thereafter accrue. Any retention or payment of moneys due Contractor by Owner will not release Contractor from liability.
- F. If and to the extent that Contractor has provided a performance bond under the provisions of Paragraph 5.01.A, the termination procedures of that bond shall supersede the provisions of Paragraphs 15.02.B, and 15.02.C.

15.03 Owner May Terminate for Convenience

- A. Upon fifteen (15) days written notice to Contractor and Construction Coordinator, Owner may, without cause and without prejudice to any other right or remedy of Owner, terminate the Contract. In such case, Contractor shall be paid for (without duplication of any items):
1. completed and acceptable Work executed in accordance with the Contract Documents prior to the effective date of termination, including fair and reasonable sums for overhead and profit on such Work;
 2. expenses sustained prior to the effective date of termination in performing services and furnishing labor, materials, or equipment as required by the Contract Documents in connection with uncompleted Work, plus fair and reasonable sums for overhead and profit on such expenses;
 3. all claims, costs, losses, and damages (including but not limited to all fees and charges of engineers, architects, attorneys, and other professionals and all court or arbitration or other dispute resolution costs) incurred in settlement of terminated contracts with Subcontractors, Suppliers, and others; and
 4. reasonable expenses directly attributable to termination.
- B. Contractor shall not be paid on account of loss of anticipated profits or revenue or other economic loss arising out of or resulting from such termination.

15.04 Contractor May Stop Work or Terminate

- A. If, through no act or fault of Contractor, (i) the Work is suspended for more than 90 consecutive days by Owner or under an order of court or other public authority, or (ii) Construction Coordinator fails to act on any Application for Payment within 30 days after it is submitted, or (iii) Owner fails for 30 days to pay Contractor any sum finally determined to be due, then Contractor may, upon seven (7) days written notice to Owner and Construction Coordinator, and provided Owner or Construction Coordinator do not remedy such suspension or failure within that time, terminate the Contract and recover from Owner payment on the same terms as provided in Paragraph 15.03.
- B. In lieu of terminating the Contract and without prejudice to any other right or remedy, if Construction Coordinator has failed to act on an Application for Payment within 30 days after it is submitted, or Owner has failed for 30 days to pay Contractor any sum finally determined to be due, Contractor may, seven (7) days after written notice to Owner and Construction Coordinator, stop the Work until payment is made of all such amounts due Contractor, including interest thereon. The provisions of this Paragraph 15.04 are not intended to preclude Contractor from making a Claim under Paragraph 10.05 for an adjustment in Contract Price or Contract Times or otherwise for expenses or damage directly attributable to Contractor's stopping the Work as permitted by this Paragraph.

PART 16 - DISPUTE RESOLUTION

16.01 Methods and Procedures

- A. Either Owner or Contractor may request mediation of any Claim submitted to Construction Coordinator for a decision under Paragraph 10.05 before such decision becomes final and binding. The mediation will be governed by the Mediation Rules of the South Carolina Supreme Court in effect as of the Effective Date of the Agreement. The request for mediation shall stay the effect of paragraph 10.05.E.
- B. Owner and Contractor shall participate in the mediation process in good faith. The process shall be concluded within 60 days of the request.
- C. If the Claim is not resolved by mediation, Engineer's action under Paragraph 10.05.C or a denial pursuant to Paragraphs 10.05.C.3 or 10.05.D shall become final and binding 30 days after termination of the mediation unless, within that time period, Owner or Contractor:
 - 1. agrees with the other party to submit the Claim to another dispute resolution process, or
 - 2. gives written notice to the other party of their intent to submit the Claim to a court of competent jurisdiction.

PART 17 - MISCELLANEOUS

17.01 Giving Notice

- A. Whenever any provision of the Contract Documents requires the giving of written notice, it will be deemed to have been validly given if:
 - 1. delivered in person to the individual or to a member of the firm or to an officer of the corporation for whom it is intended, or
 - 2. delivered at or sent by registered or certified mail, postage prepaid, to the last business address known to the giver of the notice.

17.02 Computation of Times

- A. When any period of time is referred to in the Contract Documents by days, it will be computed to exclude the first and include the last day of such period. If the last day of any such period falls on a Saturday or Sunday or on a day made a legal holiday by the law of the applicable jurisdiction, such day will be omitted from the computation.

17.03 Cumulative Remedies

- A. The duties and obligations imposed by these General Conditions and the rights and remedies available hereunder to the parties hereto are in addition to, and are not to be construed in any way as a limitation of, any rights and remedies available to any or all of them which are otherwise imposed or available by Laws or Regulations, by special warranty or guarantee, or by other provisions of the Contract Documents. The provisions of this Paragraph will be as effective as if repeated specifically in the Contract Documents in connection with each particular duty, obligation, right, and remedy to which they apply.

17.04 Survival of Obligations

- A. All representations, indemnifications, warranties, and guarantees made in, required by, or given in accordance with the Contract Documents, as well as all continuing obligations indicated in the Contract Documents, will survive final payment, completion, and acceptance of the Work or termination or completion of the Contract or termination of the services of Contractor.

17.05 Controlling Law

- A. This Contract is to be governed by the law of the State of South Carolina.

17.06 Headings

- A. Part and paragraph headings are inserted for convenience only and do not constitute parts of these General Conditions.

GENERAL PROJECT INFORMATION

BUILDING DESIGN & CODE INFORMATION

SOUTH CAROLINA MAP

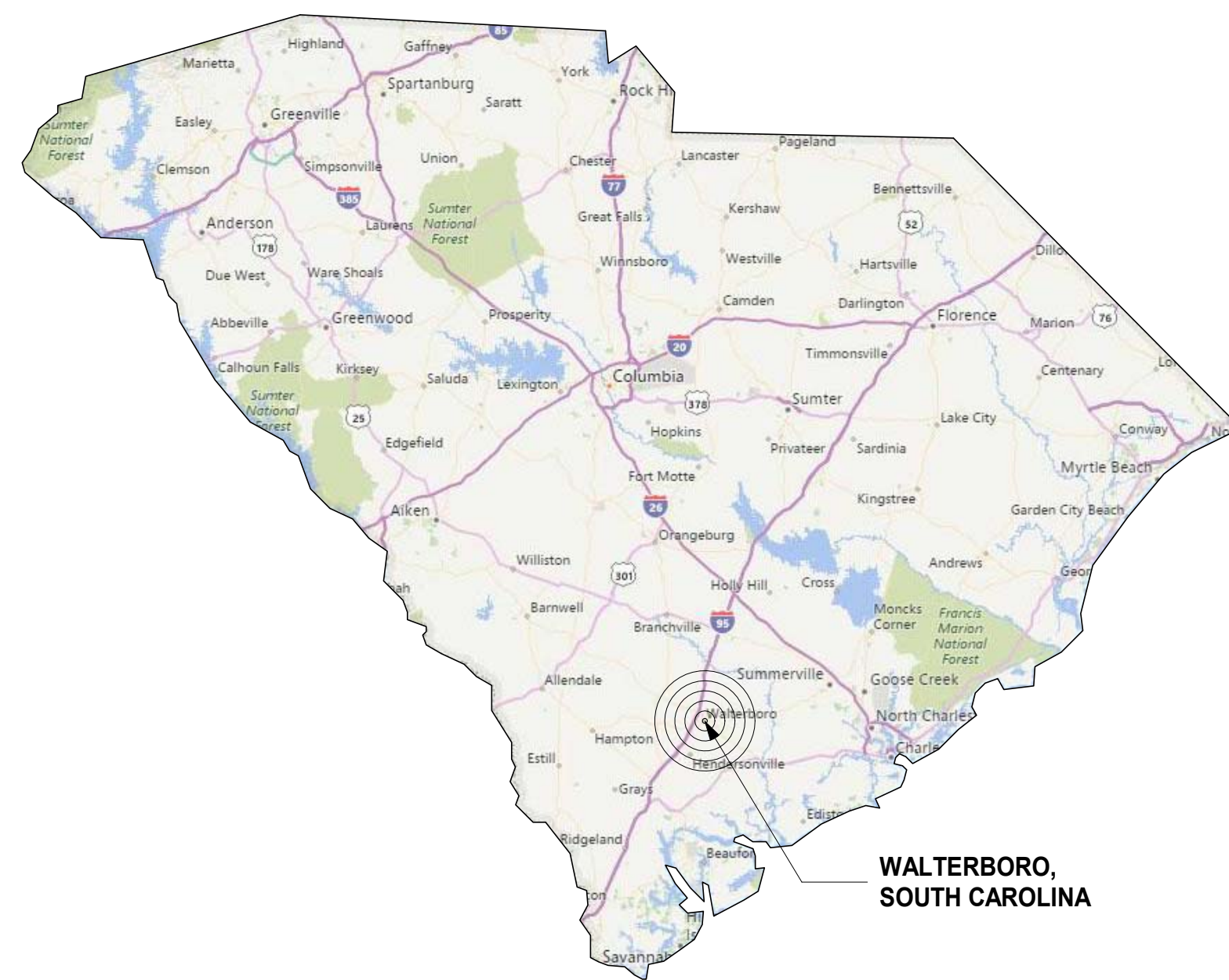

WALTERBORO, SOUTH CAROLINA

PROJECT LOCATION MAP

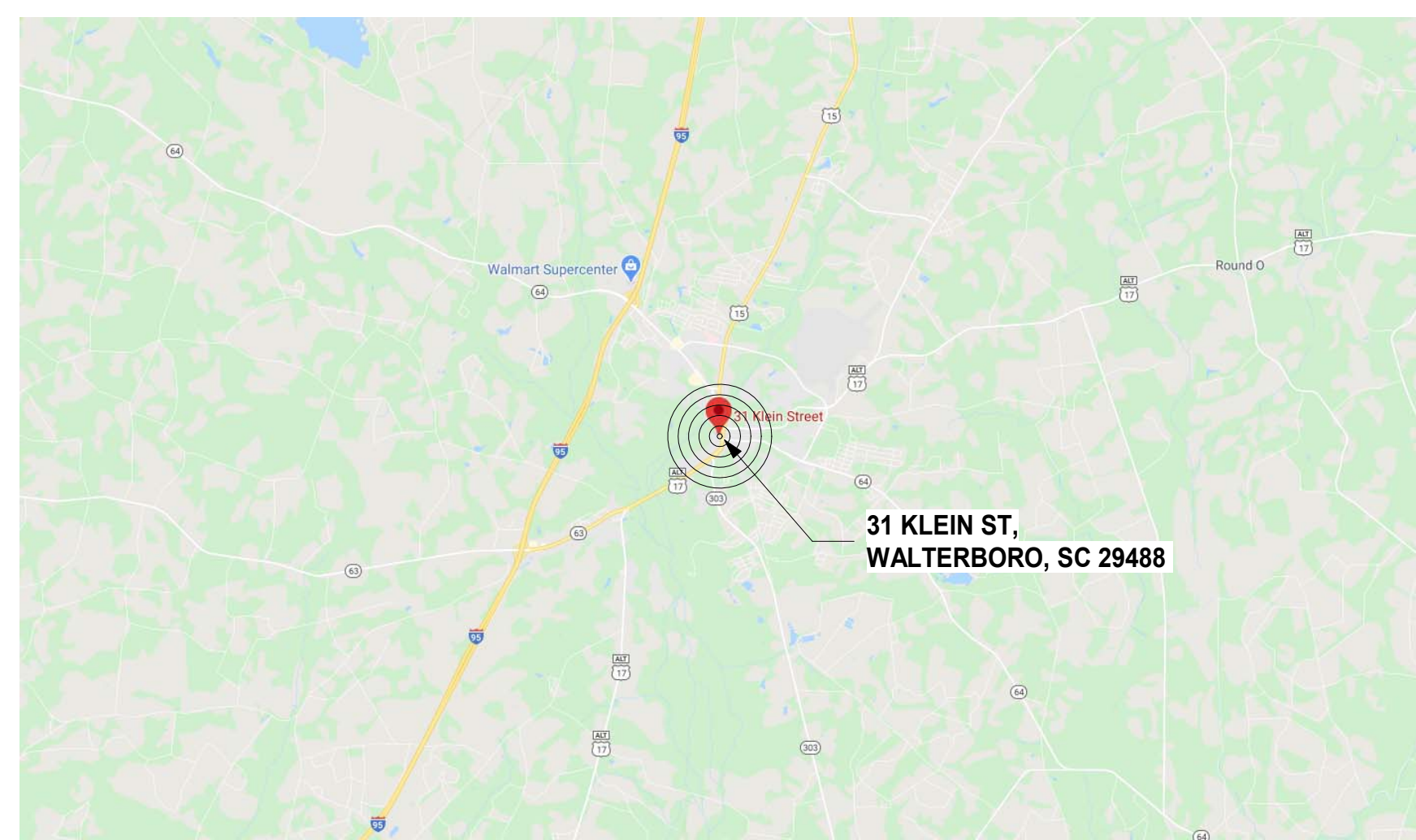

31 KLEIN ST, WALTERBORO, SC 29488

HISTORIC WALTERBORO MAP

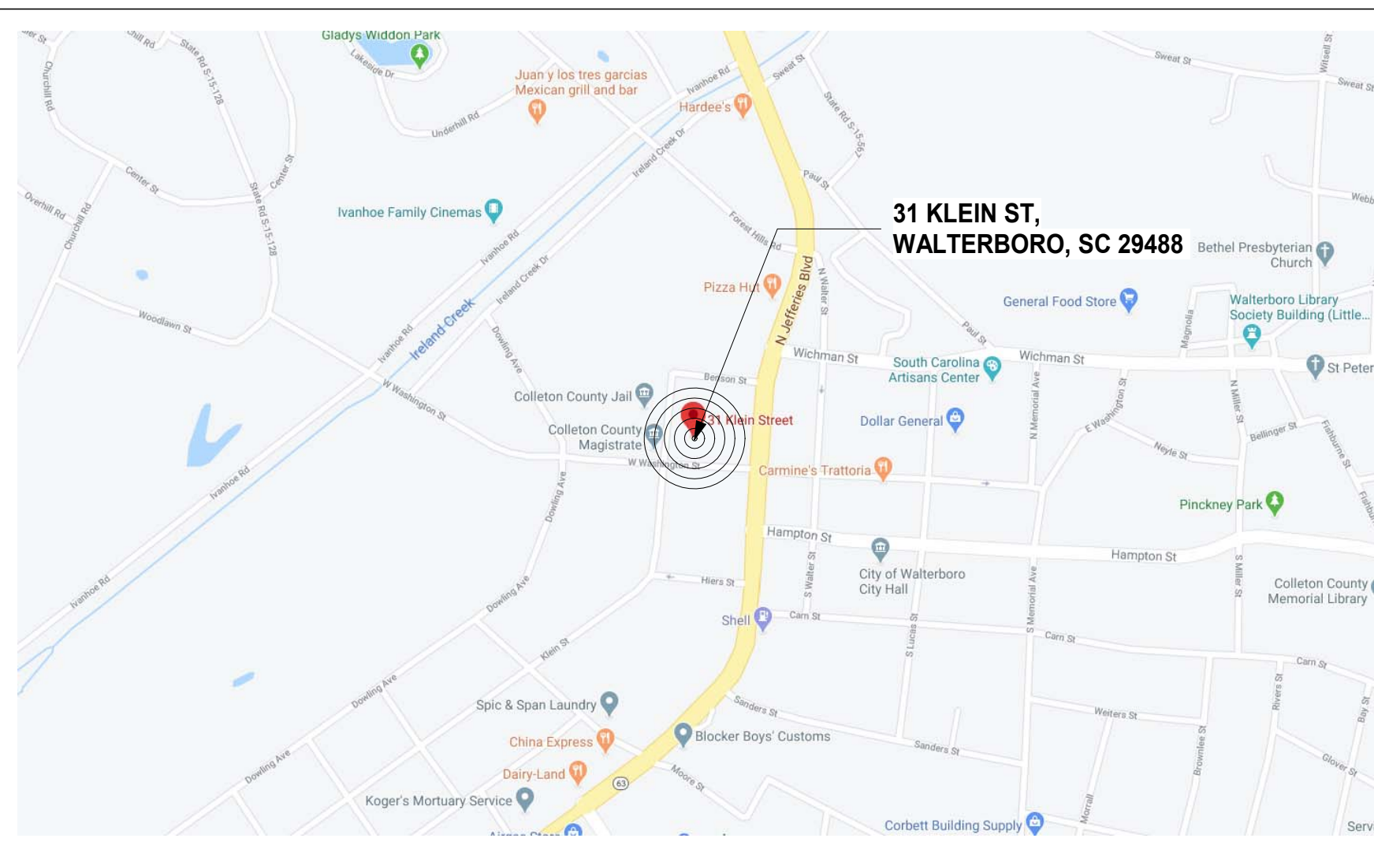

31 KLEIN ST, WALTERBORO, SC 29488

PROJECT SCOPE

NEW IT DATA CENTER FOR EXISTING HARRELSON BUILDING INCLUDING ELEVATED FLOORING SYSTEM AND RAMP FOR DATA CENTER.

DRAWING LIST

| SHEET NO. | SHEET TITLE |
|---------------|--|
| GENERAL | |
| G000 | COVER SHEET |
| G100 | DRAWING LIST & PROJECT LOCATION |
| G110 | LIFE SAFETY |
| ARCHITECTURAL | |
| AD100 | DEMO IT PLANS (PHASE 1) |
| A100 | NEW IT PLANS (PHASE 1) |
| AD101 | DEMO IT PLANS (PHASE 2) |
| A101 | NEW IT PLANS (PHASE 2) |
| AD102 | DEMO IT PLANS (PHASE 3) |
| A102 | NEW IT PLANS (PHASE 3) |
| A560 | INTERIOR RCP DETAILS |
| A600 | FINISH & DOOR SCHEDULE |
| MECHANICAL | |
| MP001 | MECHANICAL NOTES, SCHEDULES & LEGENDS |
| MP002 | MECHANICAL DETAILS |
| MP100 | FIRST FLOOR HVAC PLAN (PHASE 1) |
| MP200 | FIRST FLOOR HVAC AND PLUMBING PLAN (PHASE 2) |
| MP201 | SECOND FLOOR HVAC PLAN (PHASE 2) |
| MP300 | FIRST FLOOR HVAC PLAN (PHASE 3) |
| MP301 | SECOND FLOOR HVAC PLAN (PHASE 3) |
| ELECTRICAL | |
| E001 | ELECTRICAL NOTES |
| E002 | ELECTRICAL SCHEDULES AND DETAILS |
| E003 | ELECTRICAL DETAILS |
| E010 | ELECTRICAL RISER DIAGRAMS |
| E011 | LOW VOLTAGE RISER DIAGRAMS AND DETAILS |
| E050 | ELECTRICAL PANEL SCHEDULES |
| E051 | ELECTRICAL PANEL SCHEDULES |
| E101 | FIRST FLOOR POWER PLANS (PHASE 1) |
| E102 | FIRST FLOOR LIGHTING PLANS (PHASE 1) |
| E103 | FIRST FLOOR SYSTEMS PLANS (PHASE 1) |
| E104 | FIRST FLOOR TELECOM PLAN (PHASE 1) |
| E201 | FIRST FLOOR POWER PLAN (PHASE 2) |
| E202 | FIRST FLOOR LIGHTING PLAN (PHASE 2) |
| E203 | FIRST FLOOR SYSTEMS PLAN (PHASE 2) |
| E204 | FIRST FLOOR TELECOM PLANS (PHASE 2) |
| E301 | FIRST FLOOR POWER PLAN (PHASE 3) |
| E302 | FIRST FLOOR LIGHTING PLANS (PHASE 3) |
| E303 | FIRST FLOOR SYSTEMS PLAN (PHASE 3) |
| E304 | FIRST FLOOR TELECOM PLAN (PHASE 3) |

DESIGN TEAM

| | |
|---|---|
| ARCHITECT GLICK/BOEHM & ASSOCIATES, INC. 493 King Street, Suite 100 Charleston, South Carolina 29403 843.577.6377 | MECHANICAL ENGINEER DWG CONSULTING ENGINEERS 1009 ANNA KNAPP BLVD. STE. 202 MOUNT PLEASANT, SC 29464 843.849.1141 |
| ELECTRICAL ENGINEER DWG CONSULTING ENGINEERS 1009 ANNA KNAPP BLVD. STE. 202 MOUNT PLEASANT, SC 29464 843.849.1141 | PLUMBING ENGINEER DWG CONSULTING ENGINEERS 1009 ANNA KNAPP BLVD. STE. 202 MOUNT PLEASANT, SC 29464 843.849.1141 |

BUILDING DESIGN OCCUPANT LOAD

| Stories & Levels | Function of Space (1) | Floor Area (2) (specify NSF or GSF) | Max Area per Occupant (3) (specify NSF or GSF) | Persons on floor for this Function (4) | Design Occupant Load |
|--|---|--|---|--|----------------------|
| 1 | BUSINESS | 6,700 | 150 GSF | 45 | 45 |
| | <i>(Add additional rows as needed for each Function Type on this story)</i> | | | | |
| Subtotal Design Occupant Load for this Story: (5) | | | | | 45 |
| 2 | BUSINESS | 6,700 | 150 GSF | 45 | 45 |
| | <i>(Add additional rows as needed for each Function Type on this story)</i> | | | | |
| Subtotal Design Occupant Load for this Story: (5) | | | | | 45 |
| 3 | BUSINESS | 6,700 | 150 GSF | 45 | 45 |
| | <i>(Add additional rows as needed for each Function Type on this story)</i> | | | | |
| Subtotal Design Occupant Load for this Story: (5) | | | | | 45 |
| <i>Add or delete rows as needed for each story & level of building (including mezzanine)</i> | | | | | |
| Total Building Design Occupant Load: (6) | | | | | 135 |
| Footnotes: | | | | | |
| 1. Provide the complete name of the Function of space using the left column of Table 1004.1.2 of the IBC. | | | | | |
| 2. Design Area per each occupant of this function on this floor in either Gross or Net square footage. | | | | | |
| 3. Allowed Floor Areas in SF per Occupant per right column in Table 1004.1.2 of the IBC. | | | | | |
| 4. Divide Column A (2) by Column B (3) for each function and enter the result, rounded up to the nearest whole person. | | | | | |
| 5. Subtotal all Column C values for this floor to yield the Design Occupant Load. | | | | | |
| 6. Total Building Design Occupant Load - sum of all Column D value | | | | | |

BUILDING AREA

| | |
|--|---|
| AREA LIMIT BY TABLE 506.2 OF IBC | 19,000 SF <i>(area limitation per story)</i> |
| AREA MODIFICATION FROM EQUATION 5-2 OF IBC (IBC 506.2.3) <i>(Insert equation from IBC 506.2.3 with completed calculations in this box)</i> (Equation 5-2) Aa = [At + (NS x If)] x Sa where: Aa = Allowable area (square feet). At = Tabular allowable area factor in accordance with Table 506.2. If = Area increase factor due to frontage (percent) as calculated in accordance with Section 506.3. NS = Tabular allowable area factor in accordance with Section 506.2 for a nonsprinklered building. Sa = Actual number of building stories above grade plane not to exceed three. For buildings equipped throughout with an automatic sprinkler system installed in accordance with Section 903.3.1.2, use the actual number of building stories above gradeplane, not to exceed four. Aa = [6,000 + (6,000 x 0.75)] x 1 | 14,250 SF <i>(maximum modified area per story)</i> |
| TOTAL ALLOWED AREA OF BUILDING <i>(Summary of all stories)</i> | 33,250 SF <i>(maximum area per story)</i> |
| AREA AS DESIGNED PER STORY <i>(Repeat for each story)</i> | 6,700 SF <i>(area per story)</i> |
| TOTAL DESIGNED AREA OF BUILDING | 20,000 SF EXISTING |

BASIC PROJECT INFO

| | |
|-----------------------|---|
| PROJECT NAME: | HARRELSON BUILDING - IT DEPARTMENT RENOVATION |
| PROJECT ADDRESS: | 31 KLEIN ST. WALTERBORO, SC 29464 |
| OWNER REPRESENTATIVE: | JOHN T. STIEGLITZ III |
| REPRS. ADDRESS: | 403 E. WASHINGTON ST. WALTERBORO, SC 29488 843.539.1969 |
| OWNER: | COLLETON COUNTY |
| OWNER ADDRESS: | 403 E. WASHINGTON ST. WALTERBORO, SC 29488 843.539.1969 |

PRIMARY CODES AND ORDINANCES USED:

- 2018 INTERNATIONAL BUILDING CODE W/ SC MODIFICATIONS
- 2018 INTERNATIONAL FIRE CODE W/ SC MODIFICATIONS
- 2018 INTERNATIONAL MECHANICAL CODE
- 2018 INTERNATIONAL PLUMBING CODE
- 2015 INTERNATIONAL FUEL GAS CODE W/ SC MODIFICATIONS
- 2018 INTERNATIONAL ENERGY CONSERVATION CODE
- 2012 NATIONAL ELECTRIC CODE
- 1992 AMERICANS WITH DISABILITY ACT
- ICC/ANSI A117.1 ACCESSIBLE AND USEABLE BUILDINGS AND FACILITIES, LATEST ED.
- SC ENERGY EFFICIENCY STANDARDS ACT
- ASHRAE 90.1-2004, ENERGY EFFICIENT DESIGN OF NEW BUILDINGS EXCEPT LOW-RISE RESIDENTIAL BUILDINGS
- STATE FIRE MARSHAL REGULATIONS

BASIC BUILDING CODE INFORMATION

| | | |
|---|---|----------------------------------|
| CONSTRUCTION CLASSIFICATION | Type III-B | (IBC 602) |
| OCCUPANCY GROUP <i>(indicate all)</i> | BUSINESS GROUP B | (IBC 302) |
| OCCUPANCY GROUP <i>(indicate most restrictive)</i> | B | (IBC Table 503) |
| Does building require Incidental Use Area Separation? | <input checked="" type="checkbox"/> No <input type="checkbox"/> Yes | (IBC 509) |
| Does building have Accessory Occupancy (ies)? What percent of story is accessory occupancy? | <input checked="" type="checkbox"/> No <input type="checkbox"/> Yes | (IBC 508.3.1) xxx SF xxx % |
| Mixed Occupancy | <input checked="" type="checkbox"/> No <input type="checkbox"/> Yes | (IBC 508) |
| Non separated | <input checked="" type="checkbox"/> No <input type="checkbox"/> Yes | (IBC 508.3) |
| Separated | <input checked="" type="checkbox"/> No <input type="checkbox"/> Yes | (IBC 508.4 (IBC506.4.1)) |
| OTHER FIRE PROTECTION SYSTEMS, DEVICES or FEATURES | | |
| <i>If the building has any special or notable fire protection or safety feature or hazard the designers should list them here, describe the performance characteristics and refer to locations in construction documents (e.g. fire extinguishers, smoke- evacuation/ -control- compartments. Note IBC §414.1.3.)</i> | | |
| NOTE: WHERE A FIRE WALL IS NECESSARY TO SEPARATE BUILDINGS, EACH BUILDING IS TO BE PROVIDED INDIVIDUAL CODE CRITERIA INFORMATION IN ACCORDANCE WITH IBC 503.1.2. | | |

| REV. | DATE | DESCRIPTION |
|------|------|-------------|
| | | |
| | | |
| | | |
| | | |
| | | |



**HARRELSON BUILDING
IT DEPARTMENT
RENOVATION**
COLLETON COUNTY
31 KLEIN STREET,
WALTERBORO, SC 29464

COPYRIGHT © 2021
GLICK/BOEHM & ASSOCIATES, INC.
JOB NUMBER: 1924
PROJECT MGR.: MCM
DRAWN BY: MCM
CHECKED BY: SM
APPROVED BY: GB
DATE ISSUED FOR: CD SET
11/04/22

**DRAWING LIST
& PROJECT
LOCATION**

G100

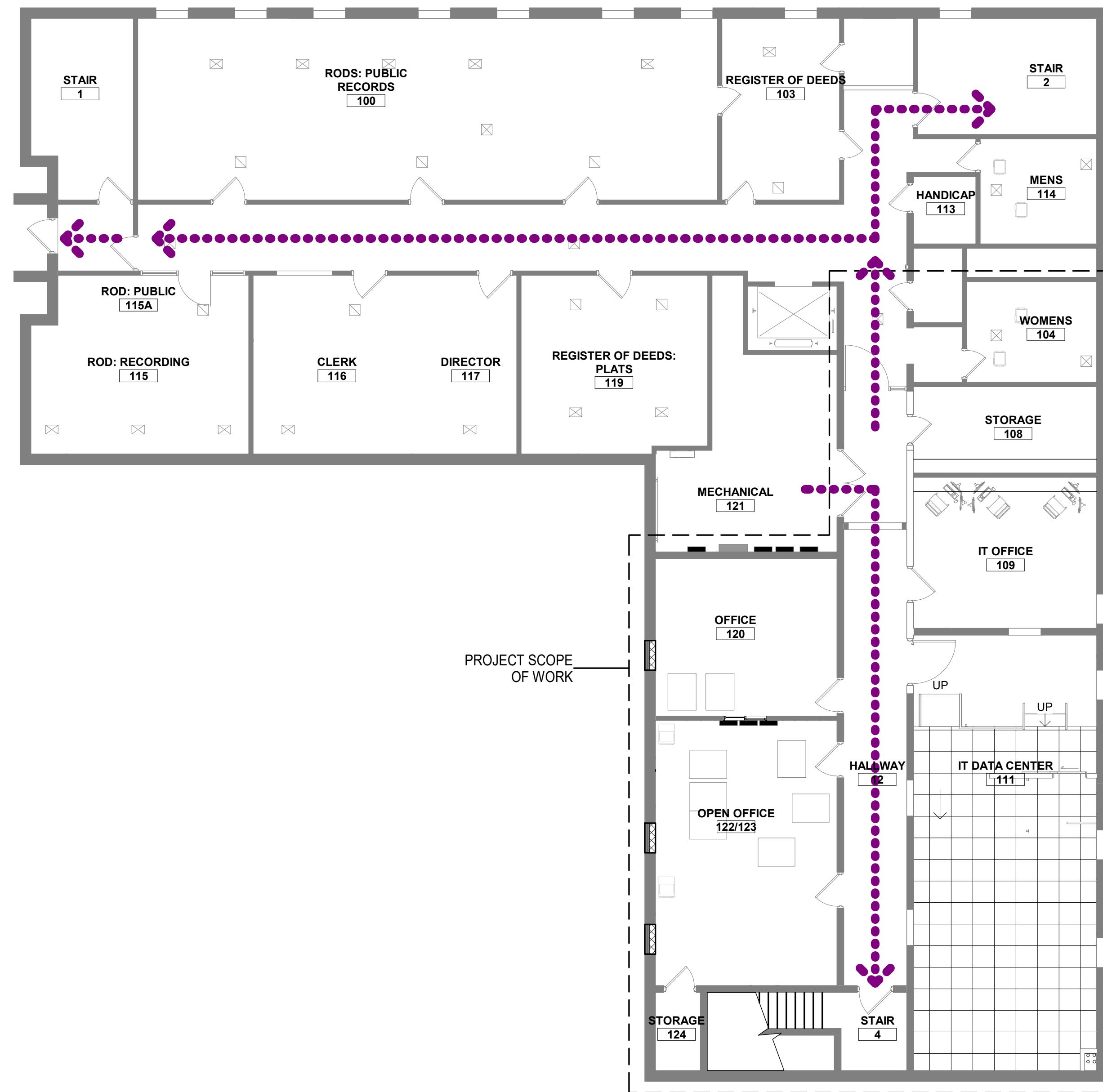

1 LIFE SAFETY PLAN
 G110 SCALE: 1/8" = 1'-0"

| REV. | DATE | DESCRIPTION |
|------|------|-------------|
| | | |
| | | |
| | | |
| | | |
| | | |
| | | |
| | | |
| | | |
| | | |
| | | |



**HARRELSON BUILDING
 IT DEPARTMENT
 RENOVATION**
 COLLETON COUNTY
 31 KLEIN STREET,
 WALTERBORO, SC 29464

COPYRIGHT © 2021
 GLICK/BOEHM & ASSOCIATES, INC.
 JOB NUMBER: 1924
 PROJECT MGR.: MCM
 DRAWN BY: Author
 CHECKED BY: Checker
 APPROVED BY: Approver
 DATE ISSUED FOR: 11/04/22
 CD SET

LIFE SAFETY

LEGEND & SYMBOLS

| | |
|--|---|
| | EXISTING WALL TO REMAIN |
| | NEW WALL |
| | NEW CMU WALL |
| | EXISTING WALL TO BE DEMOLISHED |
| | WALL SOFFIT / ROOF ABOVE |
| | DOOR MARK - A600 |
| | WALL TYPE MARK - SEE A100 |
| | ROOM TAG - SEE A600 FOR FINISH SCHEDULE |

LEGEND & SYMBOLS

| | |
|--|--|
| | 2' X 4' ACT CEILING GRID SYSTEM |
| | 2' x 4' LIGHT FIXTURE; REFER TO ELECTRICAL DRAWINGS |
| | LINEAR LIGHT FIXTURE; REFER TO ELECTRICAL DRAWINGS |
| | STRIP LIGHT FIXTURE; REFER TO ELECTRICAL DRAWINGS |
| | RECESSED CAN LIGHT FIXTURE; REFER TO ELECTRICAL DRAWINGS |
| | WALL MOUNTED LIGHT FIXTURE; REFER TO ELECTRICAL DRAWINGS |
| | SUPPLY DIFFUSER; REFER TO MECHANICAL DRAWINGS |
| | RETURN DIFFUSER; REFER TO MECHANICAL DRAWINGS |

MANSONRY INFILL NOTES

- MASONRY UNITS SHALL BE TWO CELL UNITS CONFORMING TO ASTM C-90
- MORTAR SHALL CONFORM TO ASTM C-270, TYPE S.
- CELLS INDICATED AS REINFORCED SHALL BE FILLED WITH 3000 PSI PEA GRAVEL CONCRETE OR MASONRY GROUT CONFORMING TO ASTM C-478
- REINFORCING STEEL SHALL CONFORM TO ASTM A-615, GRADE 60.
- HORIZONTAL JOINT REINFORCING SHALL BE FABRICATED FROM COLD-DRAWN STEEL WIRE, ASTM A-82, WIRE SHALL BE ZINC COATED BY THE HOT-DIP PROCESS IN ACCORDANCE WITH ASTM A-153.
- IN LOCATIONS WHERE ADJACENT CMU HAS BEEN FURRED AND FINISHED WITH GYPSUM WALL BOARD, CONTRACTOR IS TO MATCH EXISTING ADJACENT CONSTRUCTION. REFER TO FINISH SCHEDULE ON A600.

GENERAL FLOOR PLAN NOTES

- DIMENSIONS INDICATED ARE FROM FACE OF STUD AND TO FACE OF MASONRY, U.O.N.
- DIMENSIONS TO EXISTING WALLS ARE TO FACE OF FINISH, U.O.N.
- COORDINATE LOCATIONS OF ADDITIONAL PENETRATIONS THROUGH WALLS AND FLOORS NOT INDICATED ON ARCHITECTURAL DRAWINGS. RE: MECHANICAL, PLUMBING AND ELECTRICAL. REFER TO STRUCTURAL FOR LINTEL OR FRAMING REQUIREMENTS.
- ALL NEW WALLS ARE TO BE TYPE W1, U.N.O.
- REFER TO SHEET A600 FOR FINISH SCHEDULE.
- REFER TO SHEET A600 FOR DOOR SCHEDULE, TYPES.



1 NEW IT PLAN - FIRST FLOOR PLAN (PHASE 1)
A100 SCALE: 1/8" = 1'-0"

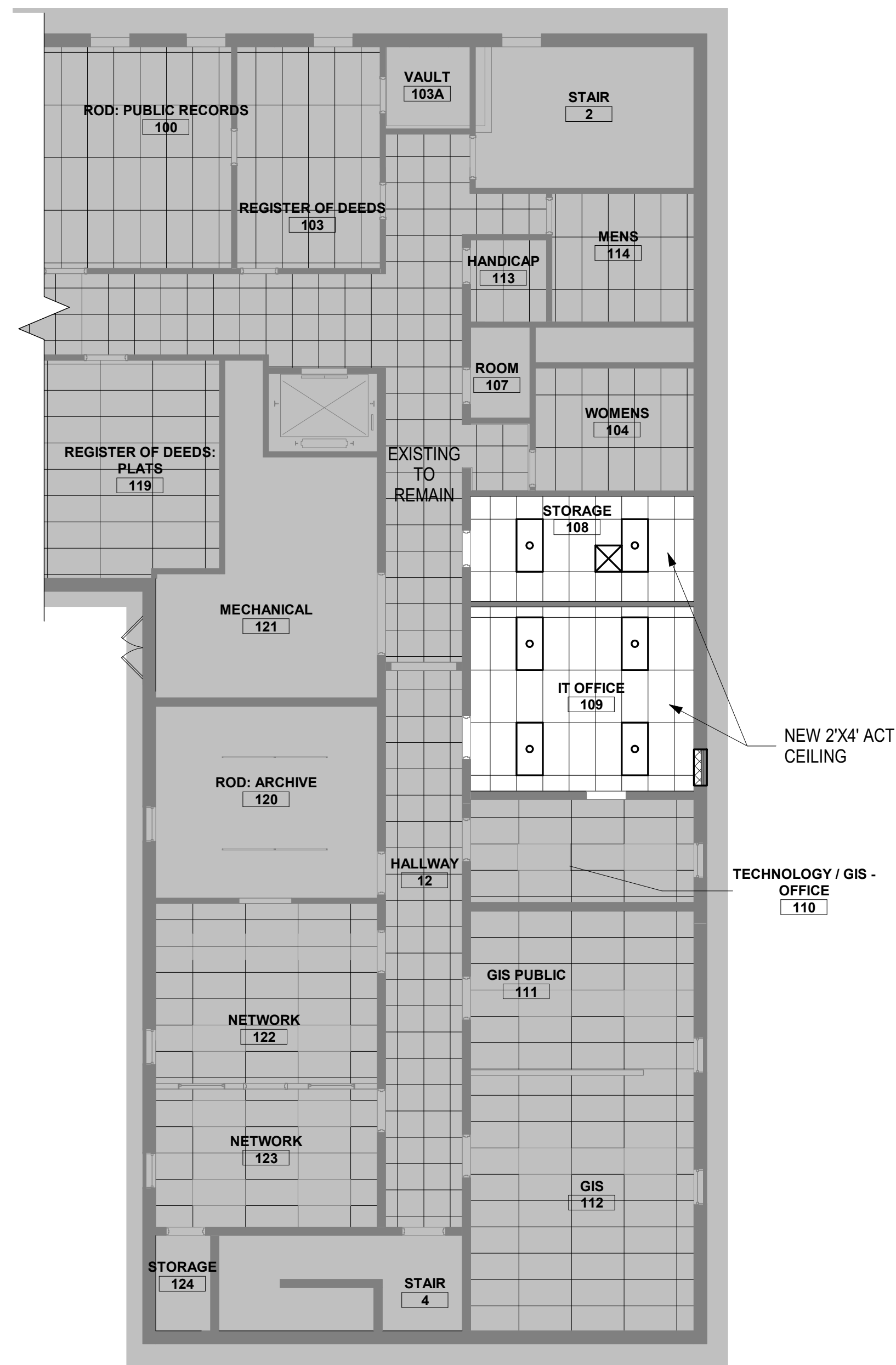

2 NEW IT RCP - FIRST FLOOR (PHASE 1)
A100 SCALE: 1/8" = 1'-0" NOTE: NEW CLG'S SHALL MATCH EXISTING CLG. HTS.

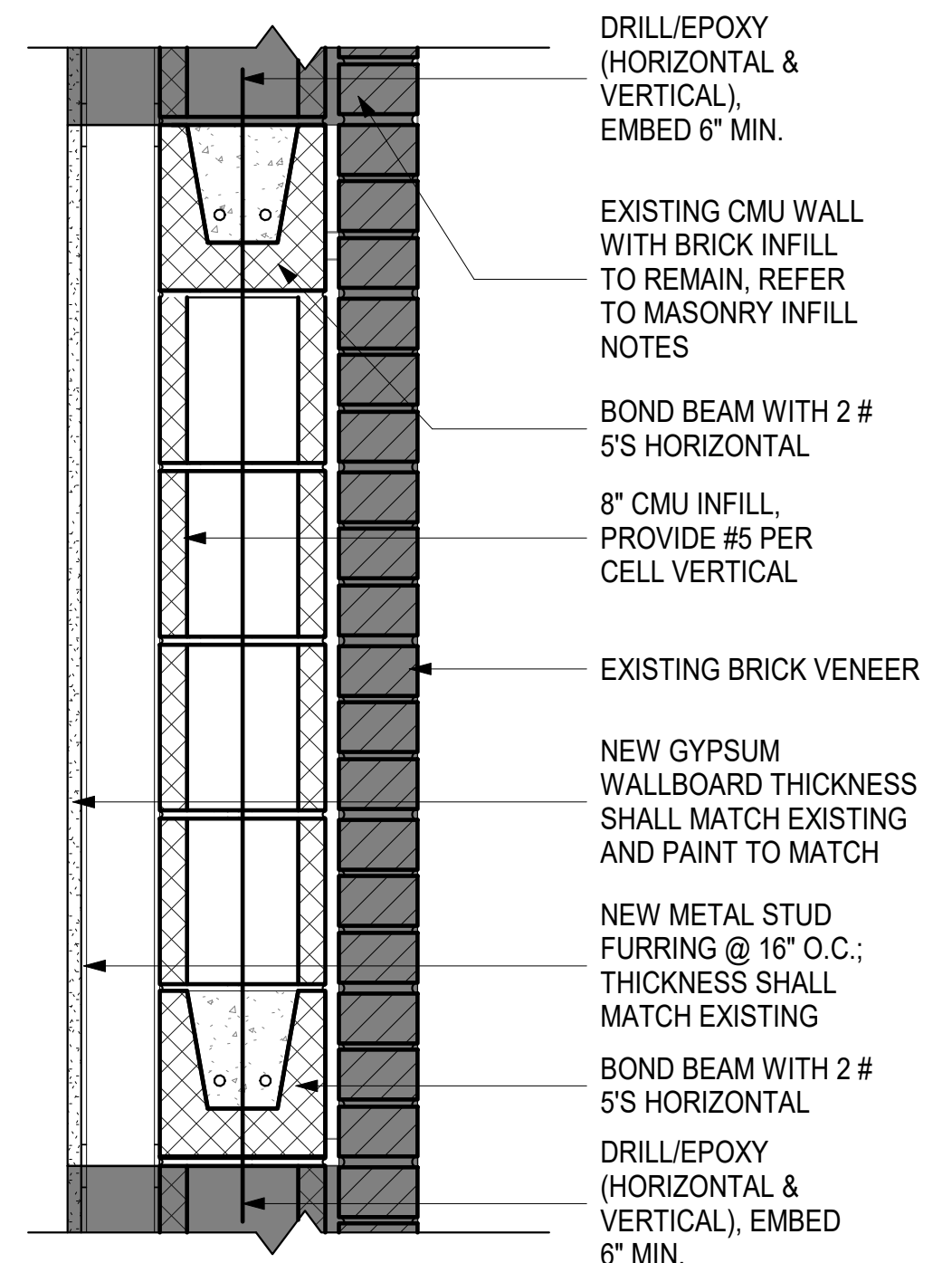

5 TYP. REINFORCEMENT DETAIL 2
A100 SCALE: 1 1/2" = 1'-0" *SEE MASONRY INFILL NOTES

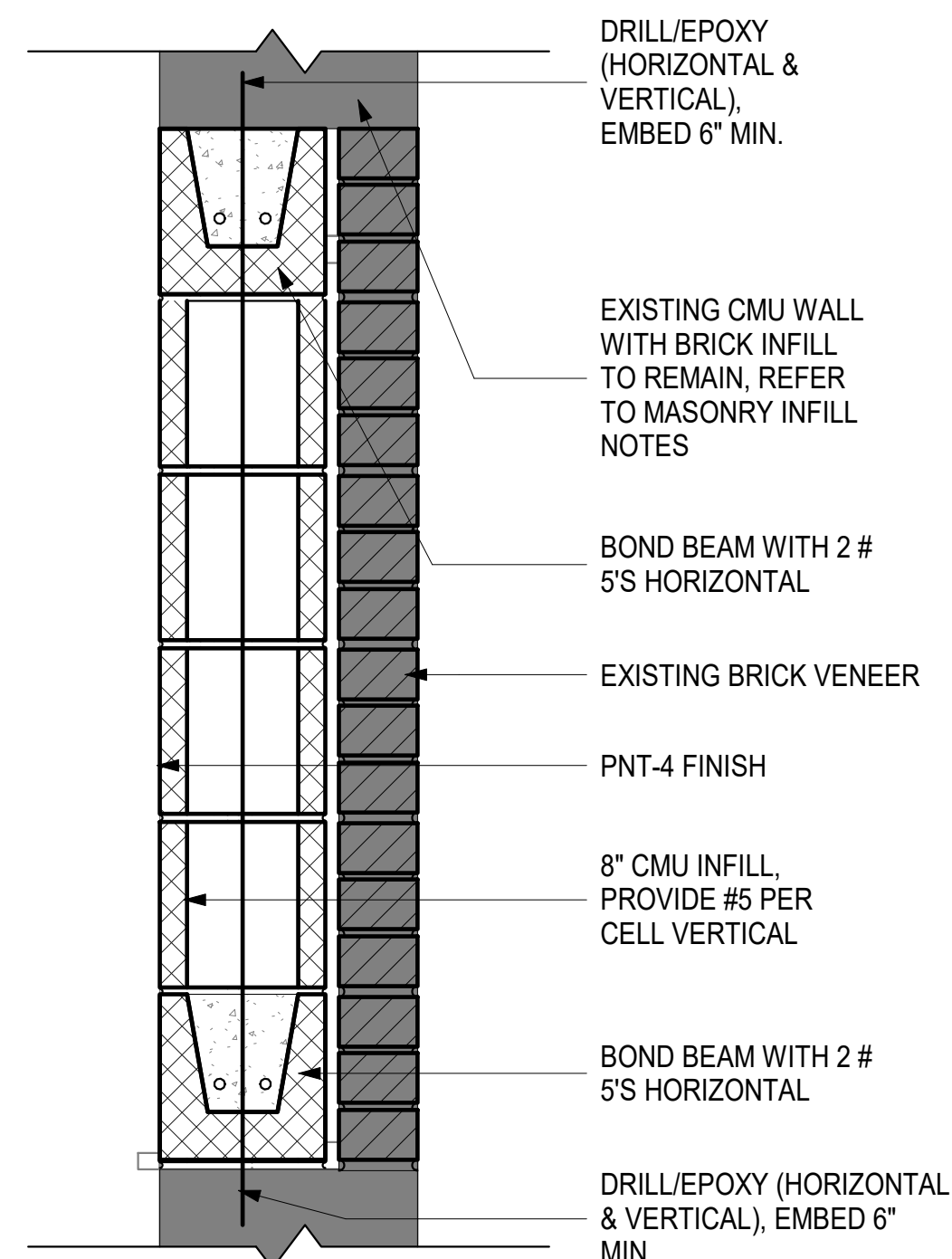

4 TYP. REINFORCEMENT DETAIL
A100 SCALE: 1 1/2" = 1'-0" *SEE MASONRY INFILL NOTES

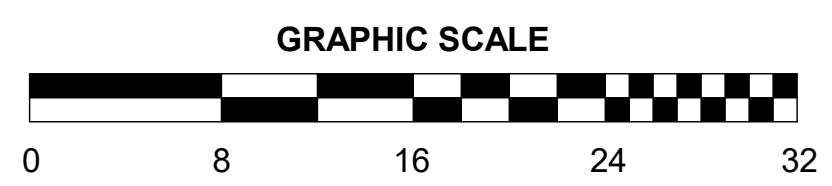

| REV. | DATE | DESCRIPTION |
|------|------|-------------|
| | | |
| | | |
| | | |
| | | |
| | | |
| | | |
| | | |
| | | |
| | | |
| | | |



**HARRELSON BUILDING
IT DEPARTMENT
RENOVATION**
COLLETON COUNTY
31 KLEIN STREET,
WALTERBORO, SC 29464

COPYRIGHT © 2021 GLICK/BOEHM & ASSOCIATES, INC.
JOB NUMBER: 1924
PROJECT MGR.: MCM
DRAWN BY: MCM
CHECKED BY: SM
APPROVED BY: GB
DATE ISSUED FOR: CD SET 11/04/22

**NEW IT PLANS
(PHASE 1)**

| REV. | DATE | DESCRIPTION |
|------|------|-------------|
| | | |
| | | |
| | | |
| | | |

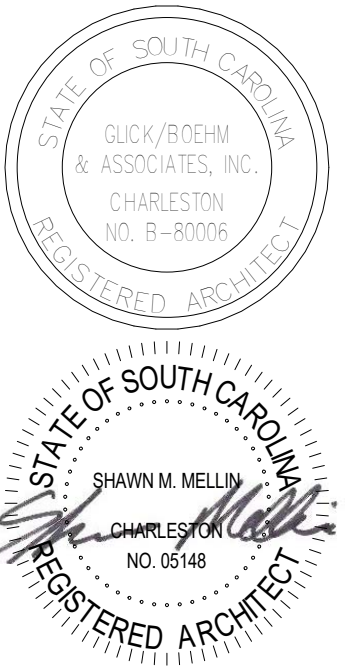

**HARRELSON BUILDING
 IT DEPARTMENT
 RENOVATION**
 COLLETON COUNTY
 31 KLEIN STREET,
 WALTERBORO, SC 29464

COPYRIGHT © 2021
 GLICK/BOEHM & ASSOCIATES, INC.
 JOB NUMBER: 1924
 PROJECT MGR.: MCM
 DRAWN BY: Author
 CHECKED BY: Checker
 APPROVED BY: Approver
 DATE ISSUED FOR: CD SET 11/04/22

**DEMO IT PLANS
 (PHASE 2)**

AD101

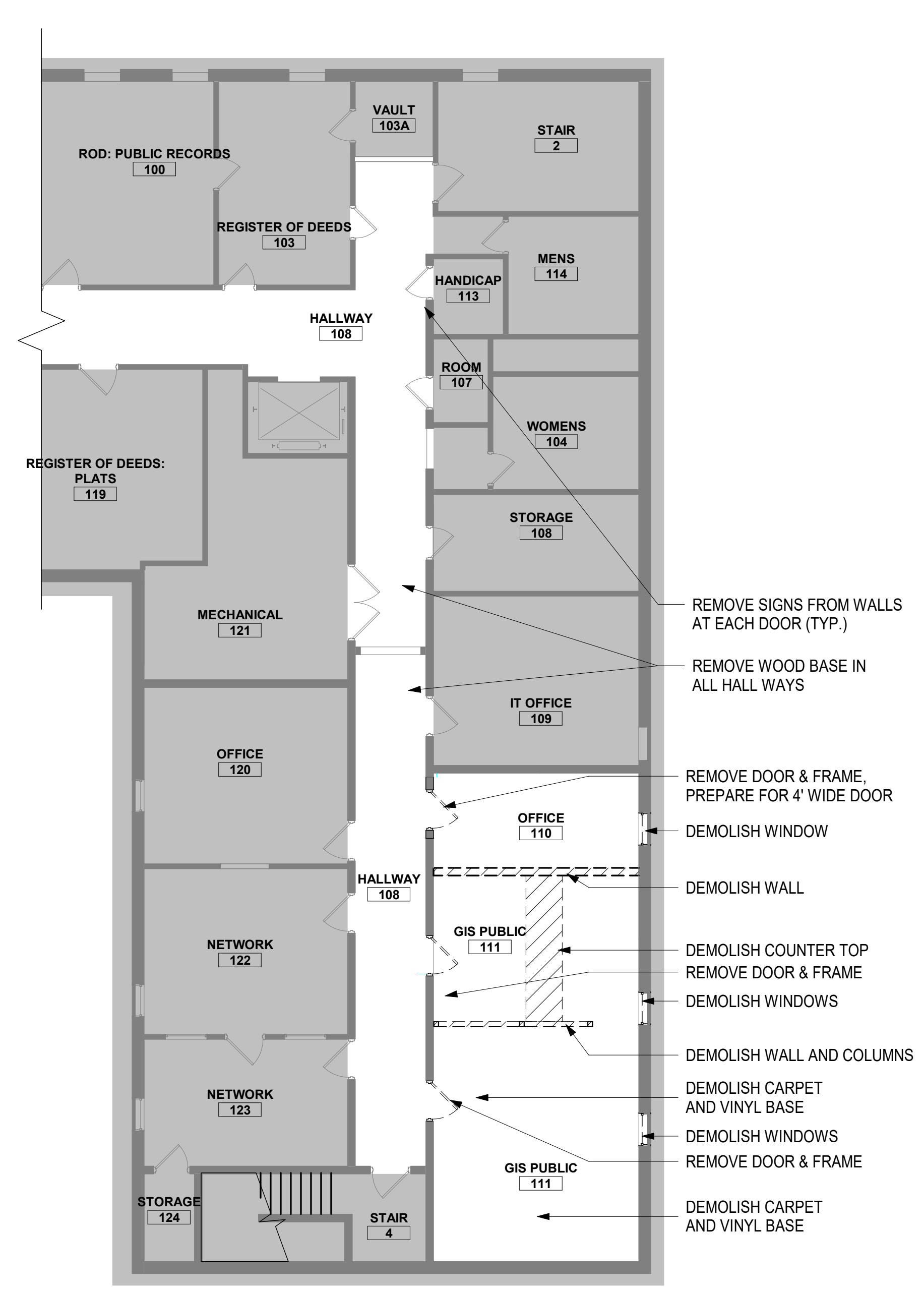

1 DEMO IT PLAN - FIRST FLOOR PLAN (PHASE 2)
 AD101 SCALE: 1/8" = 1'-0"

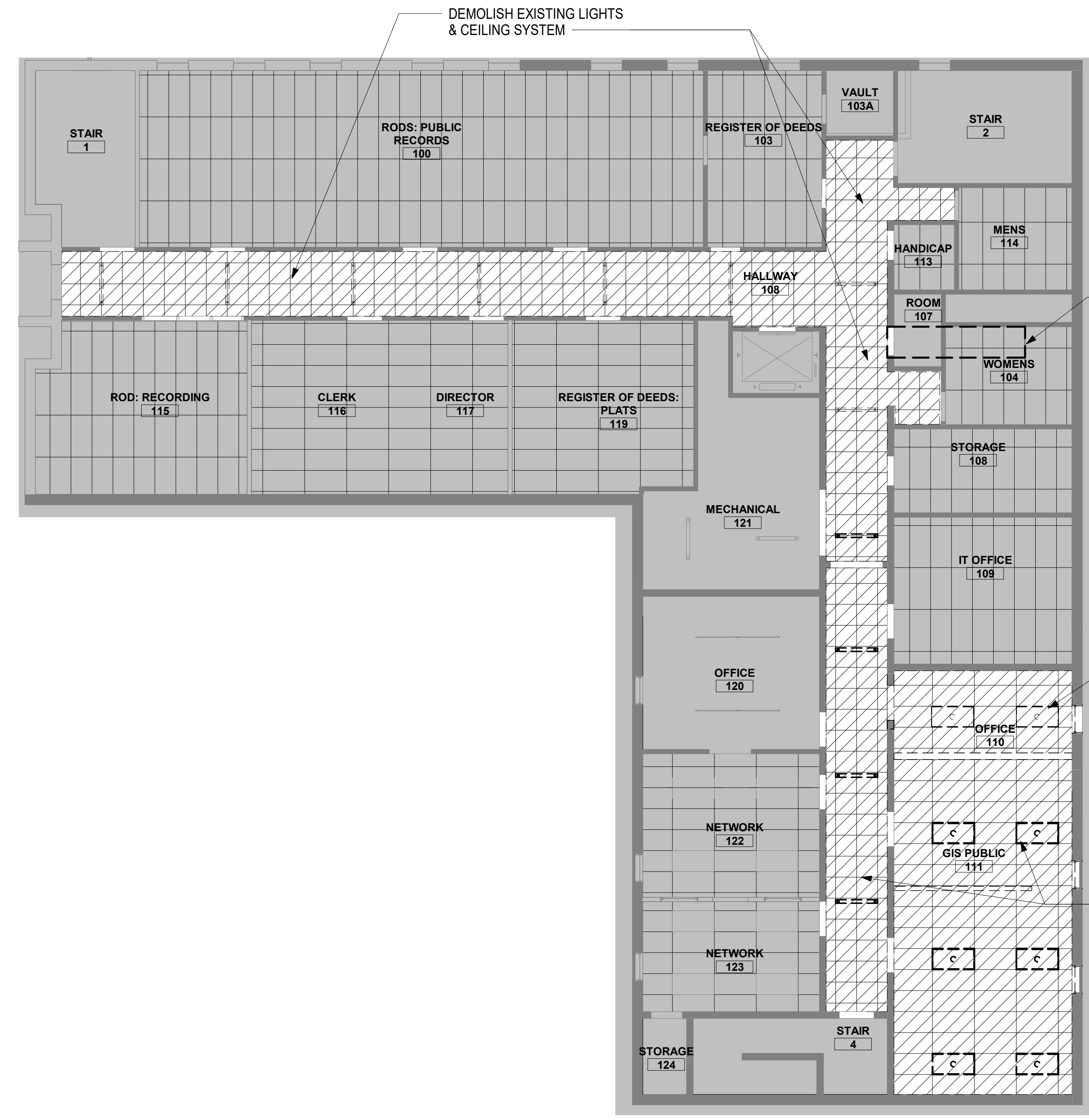

2 DEMO IT PLAN - REFLECTED CEILING PLAN (PHASE 2)
 AD101 SCALE: 1/8" = 1'-0"

COORDINATE CEILING WORK WITH NEW CONDUIT + CABLING REFER TO ELECTRICAL DWGS.

DEMOLISH EXISTING LIGHTS AND CEILING SYSTEM

DEMOLISH EXISTING LIGHTS AND CEILING SYSTEM

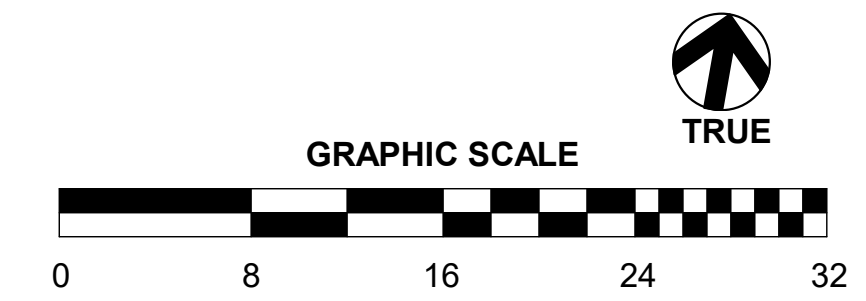

LEGEND & SYMBOLS

| | |
|--|---------------------------------------|
| | EXISTING CMU WALL TO REMAIN |
| | EXISTING ITEM / AREA TO BE DEMOLISHED |
| | EXISTING DOOR TO BE DEMOLISHED |
| | EXISTING WINDOW TO BE DEMOLISHED |
| | DEMOLITION KEYNOTE TAG |

LEGEND & SYMBOLS

| | |
|--|---|
| | EXISTING WALL TO REMAIN |
| | NEW WALL |
| | NEW CMU WALL |
| | EXISTING WALL TO BE DEMOLISHED |
| | WALL SOFFIT / ROOF ABOVE |
| | DOOR MARK - A600 |
| | WALL TYPE MARK - SEE A100 |
| | ROOM TAG - SEE A600 FOR FINISH SCHEDULE |

LEGEND & SYMBOLS

| | |
|--|--|
| | 2' X 4' ACT CEILING GRID SYSTEM |
| | 2' X 4' LIGHT FIXTURE; REFER TO ELECTRICAL DRAWINGS |
| | LINEAR LIGHT FIXTURE; REFER TO ELECTRICAL DRAWINGS |
| | STRIP LIGHT FIXTURE; REFER TO ELECTRICAL DRAWINGS |
| | RECESSED CAN LIGHT FIXTURE; REFER TO ELECTRICAL DRAWINGS |
| | WALL MOUNTED LIGHT FIXTURE; REFER TO ELECTRICAL DRAWINGS |
| | SUPPLY DIFFUSER; REFER TO MECHANICAL DRAWINGS |
| | RETURN DIFFUSER; REFER TO MECHANICAL DRAWINGS |

MANSONRY INFILL NOTES

- MASONRY UNITS SHALL BE TWO CELL UNITS CONFORMING TO ASTM C-90
- MORTAR SHALL CONFORM TO ASTM C-270, TYPE S.
- CELLS INDICATED AS REINFORCED SHALL BE FILLED WITH 3000 PSI PEA GRAVEL CONCRETE OR MASONRY GROUT CONFORMING TO ASTM C-478
- REINFORCING STEEL SHALL CONFORM TO ASTM A-615, GRADE 60.
- HORIZONTAL JOINT REINFORCING SHALL BE FABRICATED FROM COLD-DRAWN STEEL WIRE, ASTM A-82, WIRE SHALL BE ZINC COATED BY THE HOT-DIP PROCESS IN ACCORDANCE WITH ASTM A-153.
- IN LOCATIONS WHERE ADJACENT CMU HAS BEEN FURRED AND FINISHED WITH GYPSUM WALL BOARD, CONTRACTOR IS TO MATCH EXISTING ADJACENT CONSTRUCTION. REFER TO FINISH SCHEDULE ON A600.

GENERAL FLOOR PLAN NOTES

- DIMENSIONS INDICATED ARE FROM FACE OF STUD AND TO FACE OF MASONRY, U.O.N.
- DIMENSIONS TO EXISTING WALLS ARE TO FACE OF FINISH, U.O.N.
- COORDINATE LOCATIONS OF ADDITIONAL PENETRATIONS THROUGH WALLS AND FLOORS NOT INDICATED ON ARCHITECTURAL DRAWINGS. RE: MECHANICAL, PLUMBING AND ELECTRICAL. REFER TO STRUCTURAL FOR LINTEL OR FRAMING REQUIREMENTS.
- ALL NEW WALLS ARE TO BE TYPE W1, U.N.O.
- REFER TO SHEET A600 FOR FINISH SCHEDULE.
- REFER TO SHEET A600 FOR DOOR SCHEDULE, TYPES.

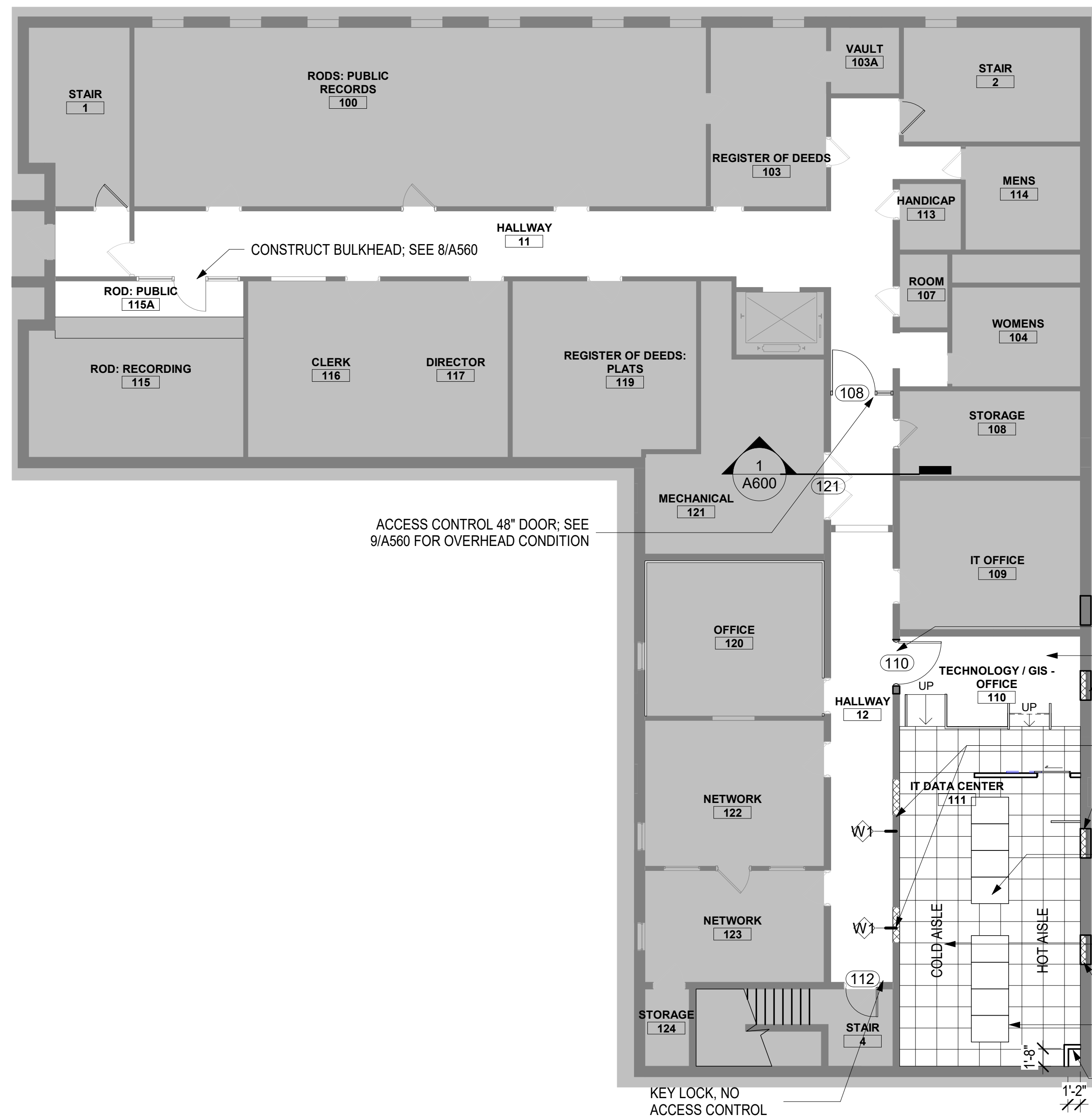

1 NEW IT PLAN - FIRST FLOOR PLAN (PHASE 2)

A101 SCALE: 1/8" = 1'-0"

2 NEW IT RCP - FIRST FLOOR (PHASE 2)

A101 SCALE: 1/8" = 1'-0"

NOTE: NEW CLG'S SHALL MATCH EXISTING CLG. HTS.

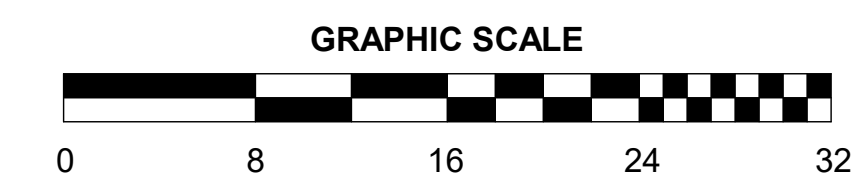

| REV. | DATE | DESCRIPTION |
|------|------|-------------|
| | | |
| | | |
| | | |
| | | |
| | | |
| | | |
| | | |
| | | |
| | | |
| | | |



**HARRELSON BUILDING
 IT DEPARTMENT
 RENOVATION**
 COLLETON COUNTY
 31 KLEIN STREET,
 WALTERBORO, SC 29464

COPYRIGHT © 2021 GLICK/BOEHM & ASSOCIATES, INC.
 JOB NUMBER: 1924
 PROJECT MGR.: MCM
 DRAWN BY: Author
 CHECKED BY: Checker
 APPROVED BY: Approver
 DATE ISSUED FOR: 11/04/22
 CD SET

**NEW IT PLANS
 (PHASE 2)**

LEGEND & SYMBOLS

| | |
|--|---|
| | EXISTING WALL TO REMAIN |
| | NEW WALL |
| | NEW CMU WALL |
| | EXISTING WALL TO BE DEMOLISHED |
| | WALL SOFFIT / ROOF ABOVE |
| | DOOR MARK - A600 |
| | WALL TYPE MARK - SEE A100 |
| | ROOM TAG - SEE A600 FOR FINISH SCHEDULE |

LEGEND & SYMBOLS

| | |
|--|--|
| | 2' x 4' ACT CEILING GRID SYSTEM |
| | 2' x 4' LIGHT FIXTURE; REFER TO ELECTRICAL DRAWINGS |
| | LINEAR LIGHT FIXTURE; REFER TO ELECTRICAL DRAWINGS |
| | STRIP LIGHT FIXTURE; REFER TO ELECTRICAL DRAWINGS |
| | RECESSED CAN LIGHT FIXTURE; REFER TO ELECTRICAL DRAWINGS |
| | WALL MOUNTED LIGHT FIXTURE; REFER TO ELECTRICAL DRAWINGS |
| | SUPPLY DIFFUSER; REFER TO MECHANICAL DRAWINGS |
| | RETURN DIFFUSER; REFER TO MECHANICAL DRAWINGS |

MANSONRY INFILL NOTES

- MASONRY UNITS SHALL BE TWO CELL UNITS CONFORMING TO ASTM C-90
- MORTAR SHALL CONFORM TO ASTM C-270, TYPE S.
- CELLS INDICATED AS REINFORCED SHALL BE FILLED WITH 3000 PSI PEA GRAVEL CONCRETE OR MASONRY GROUT CONFORMING TO ASTM C-478
- REINFORCING STEEL SHALL CONFORM TO ASTM A-615, GRADE 60.
- HORIZONTAL JOINT REINFORCING SHALL BE FABRICATED FROM COLD-DRAWN STEEL WIRE, ASTM A-82, WIRE SHALL BE ZINC COATED BY THE HOT-DIP PROCESS IN ACCORDANCE WITH ASTM A-153.
- IN LOCATIONS WHERE ADJACENT CMU HAS BEEN FURRED AND FINISHED WITH GYPSUM WALL BOARD, CONTRACTOR IS TO MATCH EXISTING ADJACENT CONSTRUCTION. REFER TO FINISH SCHEDULE ON A600.

GENERAL FLOOR PLAN NOTES

- DIMENSIONS INDICATED ARE FROM FACE OF STUD AND TO FACE OF MASONRY, U.O.N.
- DIMENSIONS TO EXISTING WALLS ARE TO FACE OF FINISH, U.O.N.
- COORDINATE LOCATIONS OF ADDITIONAL PENETRATIONS THROUGH WALLS AND FLOORS NOT INDICATED ON ARCHITECTURAL DRAWINGS. RE: MECHANICAL, PLUMBING AND ELECTRICAL. REFER TO STRUCTURAL FOR LINTEL OR FRAMING REQUIREMENTS.
- ALL NEW WALLS ARE TO BE TYPE W1, U.N.O.
- REFER TO SHEET A600 FOR FINISH SCHEDULE.
- REFER TO SHEET A600 FOR DOOR SCHEDULE, TYPES.

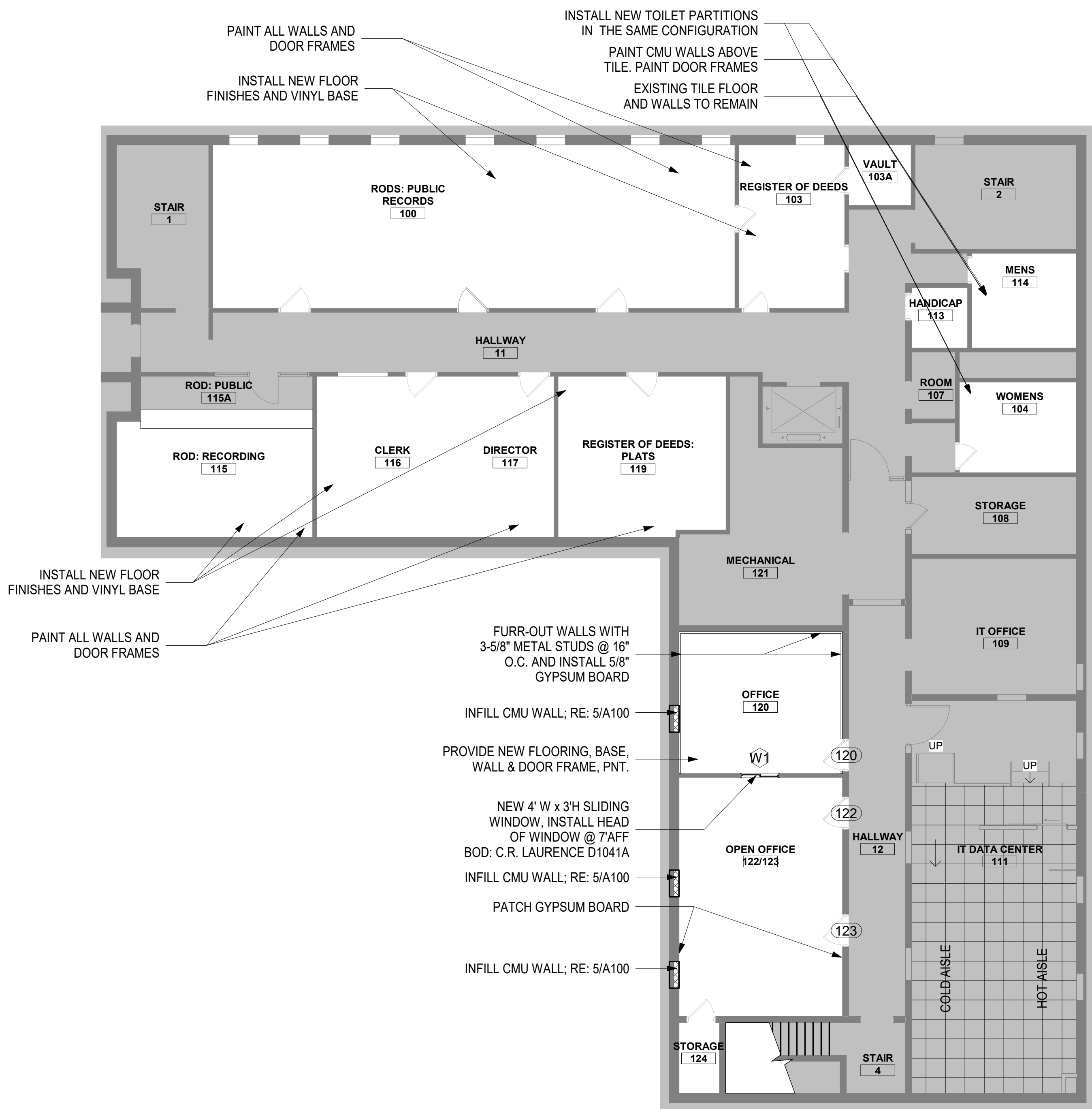
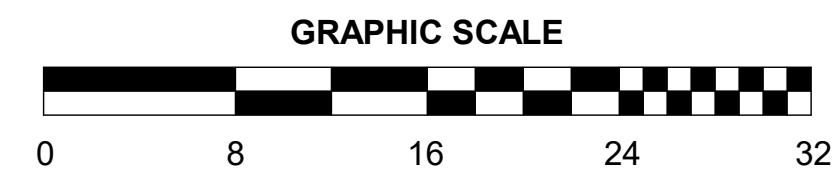

1 NEW IT PLAN - FIRST FLOOR PLAN (PHASE 3)
A102 SCALE: 1/8" = 1'-0"



2 NEW IT RCP - FIRST FLOOR (PHASE 3)
A102 SCALE: 1/8" = 1'-0"

NOTE: NEW CLG'S SHALL MATCH EXISTING CLG. HTS.

| REVISION | DATE | DESCRIPTION |
|----------|------|-------------|
| | | |
| | | |
| | | |
| | | |
| | | |
| | | |
| | | |
| | | |
| | | |
| | | |

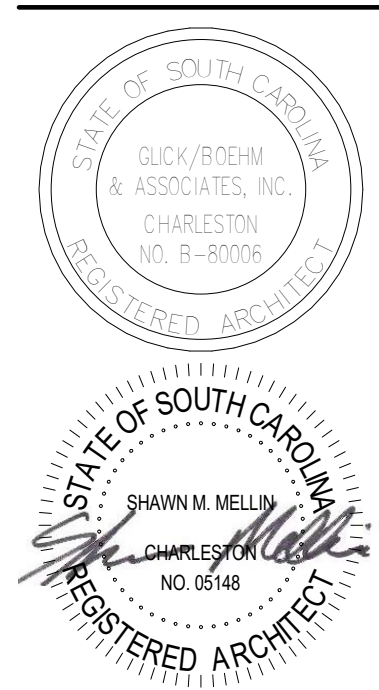

**HARRELSON BUILDING
IT DEPARTMENT
RENOVATION**
COLLETON COUNTY
31 KLEIN STREET,
WALTERBORO, SC 29464

COPYRIGHT © 2021
GLICK/BOEHM & ASSOCIATES, INC.
JOB NUMBER: 1924
PROJECT MGR.: MCM
DRAWN BY: Author
CHECKED BY: Checker
APPROVED BY: Approver
DATE ISSUED FOR: CD SET 11/04/22

**NEW IT PLANS
(PHASE 3)**

SEISMIC RESTRAINTS FOR SUSP'D ACOUSTICAL CEILINGS

| # | CEILING COMPONENT | IBC CATEGORY "C" CISCA ZONES 0-2 | IBC CATEGORY "D", "E" OR "F" - CISCA ZONES 3 & 4 | | DETAIL | REMARKS |
|-----|---|--|--|--|--------|---------|
| | | | UP TO 1,000 SF | GREATER THAN 1,000 SF | | |
| 1. | INTERSECTION STRENGTH AT MAIN / CROSS TEES | 60 LBS. | 180 LBS. | 180 LBS. | 5/A570 | |
| 2. | HANGER WIRE (MIN. OF 3 TWISTS) | 12 GAUGE @ 4' o.c. EACH WAY | 12 GAUGE @ 4' o.c. EACH WAY | 12 GAUGE @ 4' o.c. EACH WAY | | |
| 3. | CONNECTION @ WIRE / STRUCTURE ABOVE | NO MINIMUM REQUIREMENT | 100 LBS. MINIMUM | 100 LBS. MINIMUM | | |
| 4. | MAIN TEE CLASSIFICATION | INTERMEDIATE DUTY OR HEAVY DUTY | HEAVY DUTY | HEAVY DUTY | | |
| 5. | MAXIMUM OUT OF PLUMB | 1 IN 6 MAXIMUM | 1 IN 6 MAXIMUM | 1 IN 6 MAXIMUM | | |
| 6. | PERIMETER WIRE DISTANCE FROM WALLS | IF WALL ANGLE < 7/8" THEN 8" MAXIMUM | 8" MAXIMUM | 8" MAXIMUM | | |
| 7. | GRID CONNECTION TO PERIMETER WALLS | NOT ALLOWED | ATTACHED TO TWO ADJACENT WALLS | ATTACHED TO TWO ADJACENT WALLS | | |
| 8. | PERIMETER TEE ENDS TIED TOGETHER | YES, WITH STABILIZER BAR | YES, WITH STABILIZER BAR | YES, WITH STABILIZER BAR | | |
| 9. | PERIMETER MOLDING WIDTH | 7/8 INCH MINIMUM | 2 INCH MINIMUM | 2 INCH MINIMUM | | |
| 10. | GRID / WALL CLEARANCE | 3/8 INCH MINIMUM | 3/4 INCH MINIMUM | 3/4 INCH MINIMUM | | |
| 11. | SPLAY BRACING 90° APART @ 45° ANGLES | NOT REQUIRED | NOT REQUIRED | REQ'D WITHIN 2" OF TEE INTERSECTION @ 12'-0" o.c. E.W. | | |
| 12. | SPLAY BRACING CONNECTION STRENGTH | N/A | N/A | GREATER OF 200 LBS. OR DESIGN LOAD | | |
| 13. | COMPRESSION POSTS | NOT REQUIRED | NOT REQUIRED | REQ'D @ 12' O.C. EACH WAY, STARTING 6' FROM WALLS | | |
| 14. | PARTITION ATTACHMENT | BRACE INDEPENDENT OF CEILING GRID | BRACE INDEPENDENT OF CEILING GRID | BRACE INDEPENDENT OF CEILING GRID | | |
| 15. | SEISMIC SEPARATION JOINT | NOT REQUIRED | NOT REQUIRED | REQUIRED WHERE AREA IS > 2,500 SF | | |
| 16. | RIGID BRACING AT CEILING PLANE CHANGES | NOT REQUIRED | YES | YES | | |
| 17. | ALL LIGHT FIXTURES ATTACHED TO GRID, TYPICAL | AT 2 POINTS UNLESS INDEPENDENTLY SUPPORTED | AT 2 POINTS UNLESS INDEPENDENTLY SUPPORTED | AT 2 POINTS UNLESS INDEPENDENTLY SUPPORTED | | |
| 18. | SURFACE MOUNTED LIGHT FIXTURE | ATTACH TO GRID | ATTACH TO GRID | ATTACH TO GRID | | |
| 19. | PENDANT HUNG LIGHT FIXTURE | SUPPORT DIRECTLY FROM STRUCTURE W/ 9 GA. WIRE | SUPPORT DIRECTLY FROM STRUCTURE W/ 9 GA. WIRE | SUPPORT DIRECTLY FROM STRUCTURE W/ 9 GA. WIRE | | |
| 20. | RECESSED LIGHT FIXTURE < 10 LBS. | SUPPORT WITH ONE WIRE TO STRUCTURE | SUPPORT WITH ONE WIRE TO STRUCTURE | SUPPORT WITH ONE WIRE TO STRUCTURE | | |
| 21. | LAY-IN OR RECESSED LIGHT FIXTURE, 10 TO 56 LBS. | TWO WIRES TO STRUCTURE ON DIAGONAL | TWO WIRES TO STRUCTURE ON DIAGONAL | TWO WIRES TO STRUCTURE ON DIAGONAL | | |
| 22. | LAY-IN OR RECESSED LIGHT FIXTURE > 56 LBS. | SUPPORT INDEPENDENTLY FROM STRUCTURE | SUPPORT INDEPENDENTLY FROM STRUCTURE | SUPPORT INDEPENDENTLY FROM STRUCTURE | | |
| 23. | AIR TERMINALS < 20 LBS. | POSITIVELY ATTACHED TO GRID | POSITIVELY ATTACHED TO GRID | POSITIVELY ATTACHED TO GRID | | |
| 24. | AIR TERMINALS, 20 TO 56 LBS. | POSITIVELY ATTACH TO GRID + 2 WIRES TO STRUCTURE | POSITIVELY ATTACH TO GRID + 2 WIRES TO STRUCTURE | POSITIVELY ATTACH TO GRID + 2 WIRES TO STRUCTURE | | |
| 25. | AIR TERMINALS > 56 LBS. | SUPPORT DIRECTLY FROM STRUCTURE | SUPPORT DIRECTLY FROM STRUCTURE | SUPPORT DIRECTLY FROM STRUCTURE | | |
| 26. | SPRINKLER HEAD CLEARANCE | 3/8 INCH ON ALL SIDES | 2 INCH MINIMUM OPENING OR SWING JOINT | 2 INCH MINIMUM OPENING OR SWING JOINT | | |
| 27. | MISC. PENETRATION CLEARANCE | 3/8 INCH ON ALL SIDES | 2 INCH MINIMUM OPENING OR FLEX JOINT | 2 INCH MINIMUM OPENING OR FLEX JOINT | | |
| 28. | CABLE TRAYS | MAY BE SUPPORTED BY GRID OR STRUCTURE | SUPPORT DIRECTLY FROM STRUCTURE | SUPPORT DIRECTLY FROM STRUCTURE | | |
| 29. | CONDUIT AND PIPING | MAY BE SUPPORTED BY GRID OR STRUCTURE | SUPPORT DIRECTLY FROM STRUCTURE | SUPPORT DIRECTLY FROM STRUCTURE | | |
| 30. | - | - | - | - | | |

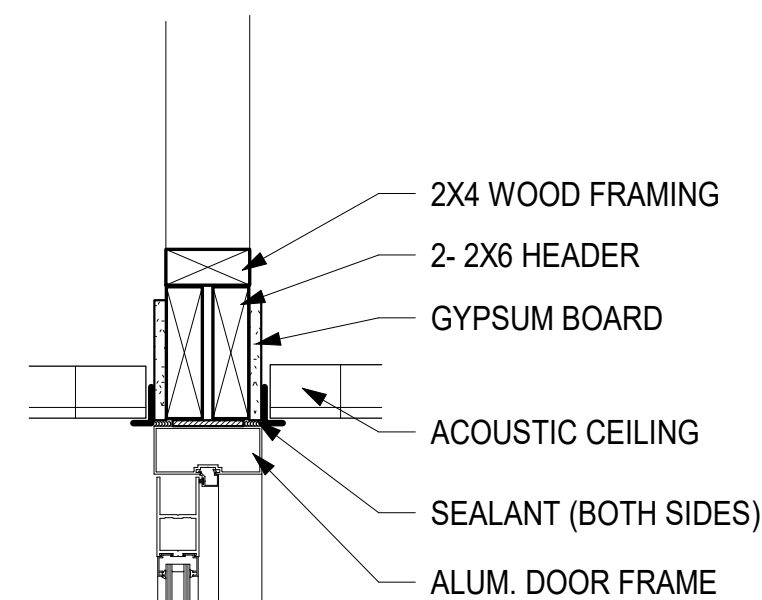

9 BULKHEAD OVER SF DOOR

A560 SCALE: 1 1/2" = 1'-0"

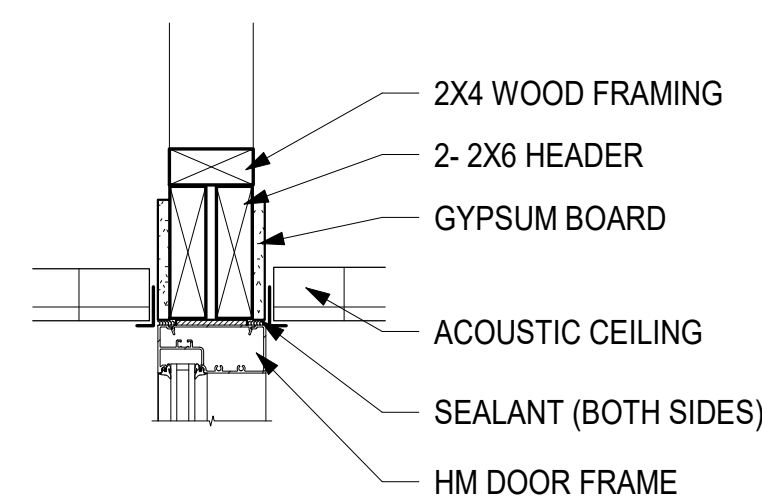

8 BULKHEAD OVER SF

A560 SCALE: 1 1/2" = 1'-0"

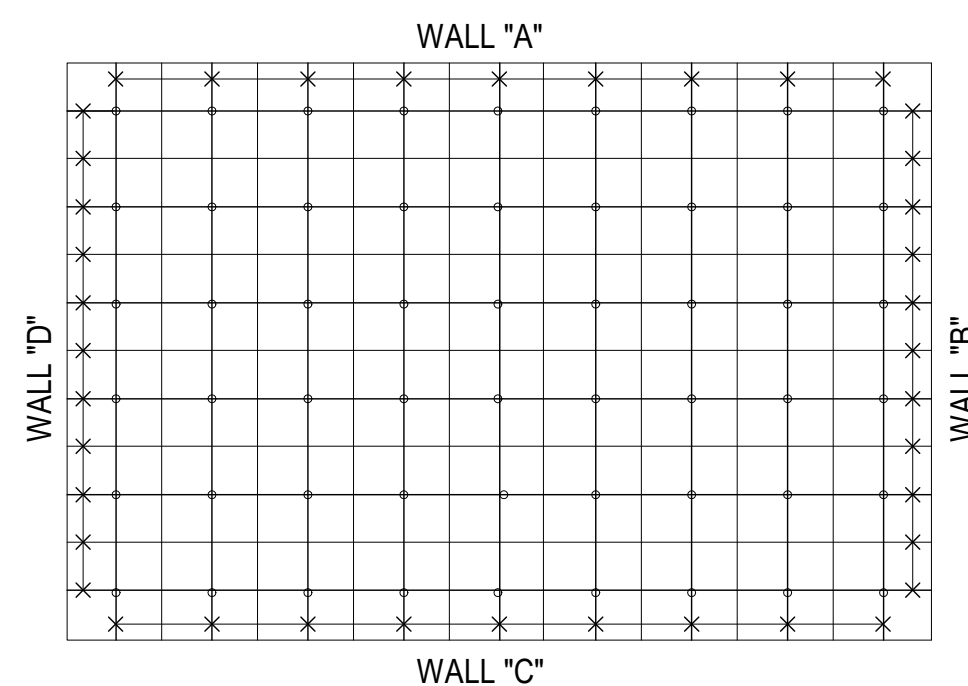

7 GRID WHEN ROOM < 1,000 SF

A560 SCALE: 1/8" = 1'-0"

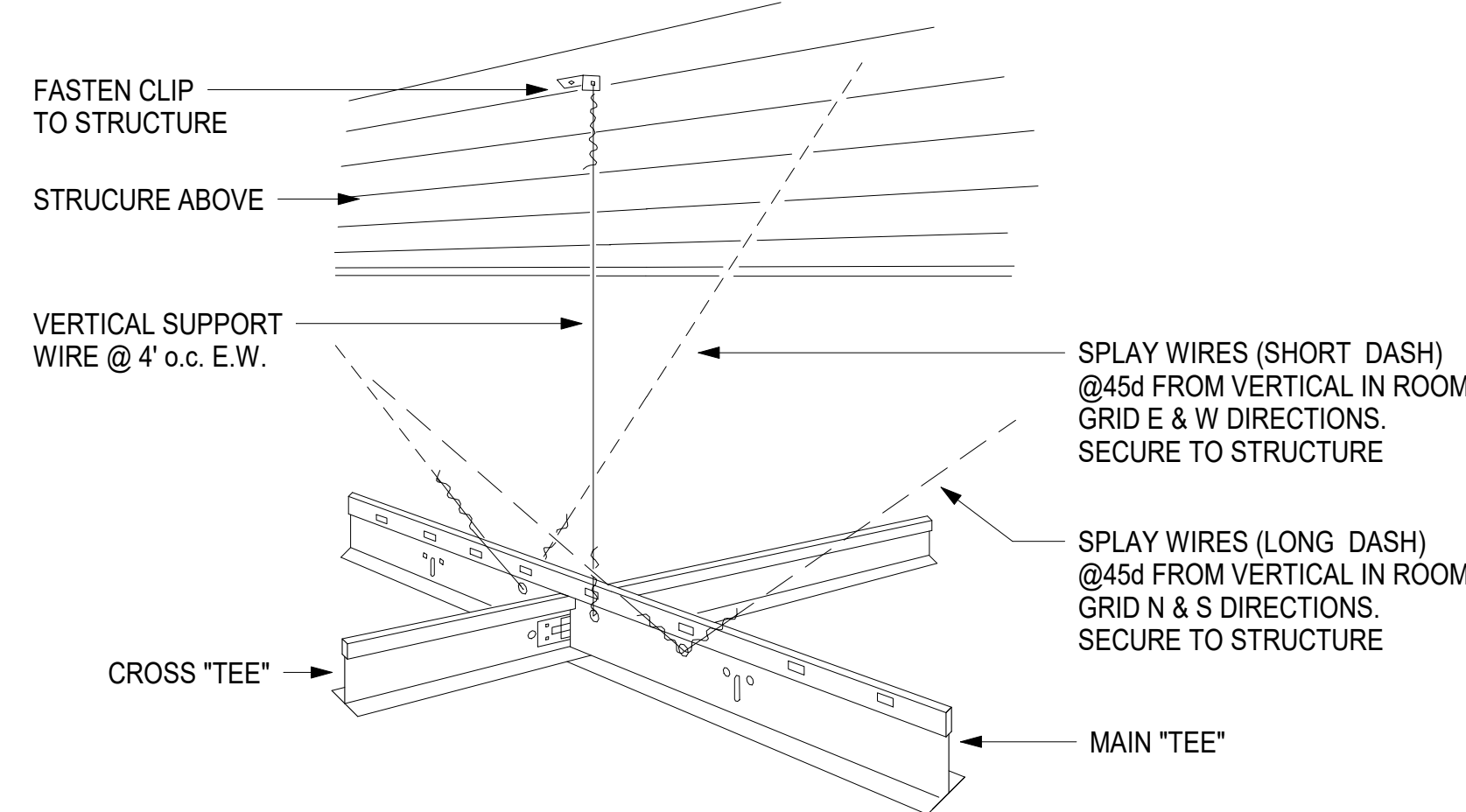

6 ACT SEISMIC SPLAY WIRE LAYOUT

A560 SCALE: 1/64" = 1'-0"

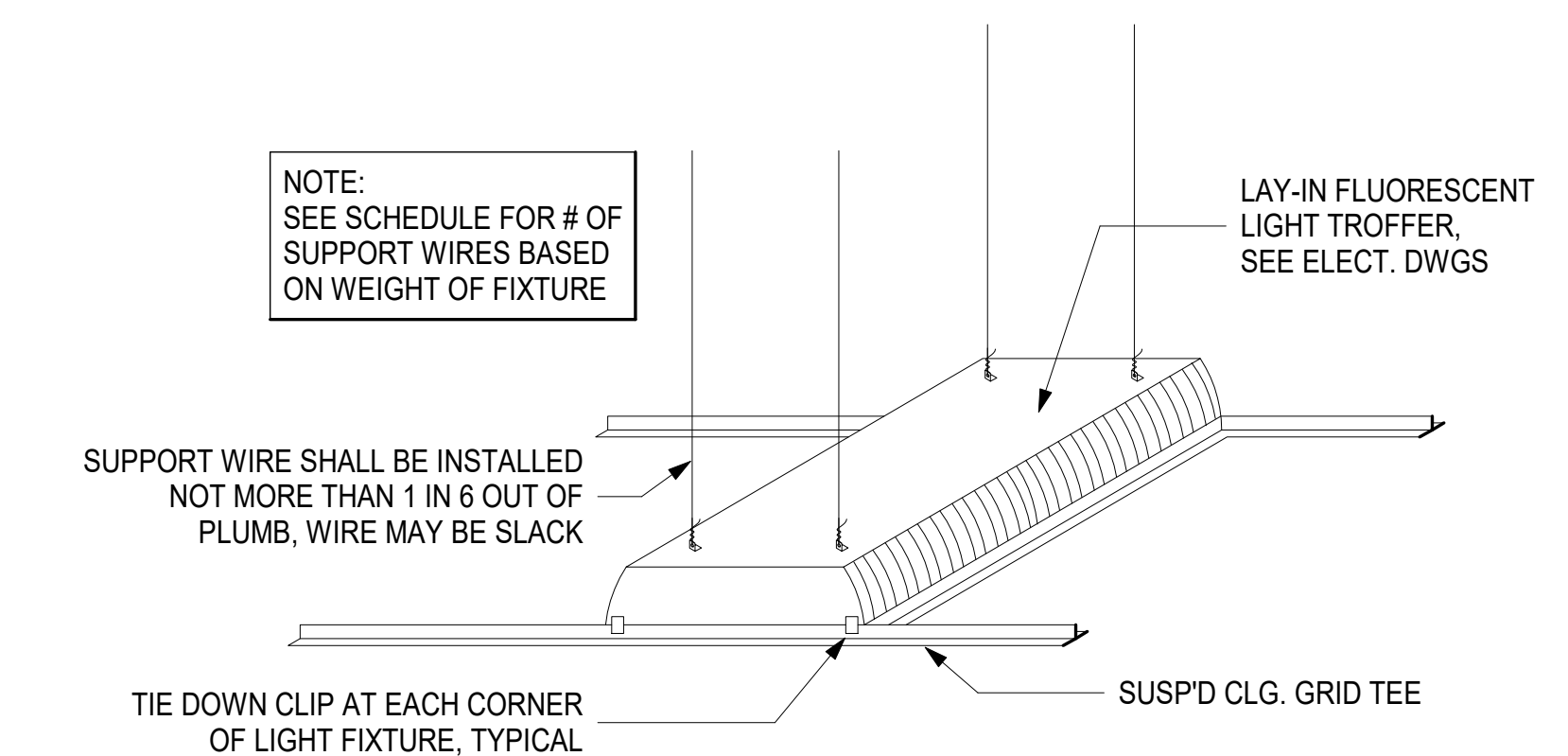

5 LAY-IN TROFFER ATTACHMENT

A560 SCALE: 1/8" = 1'-0"

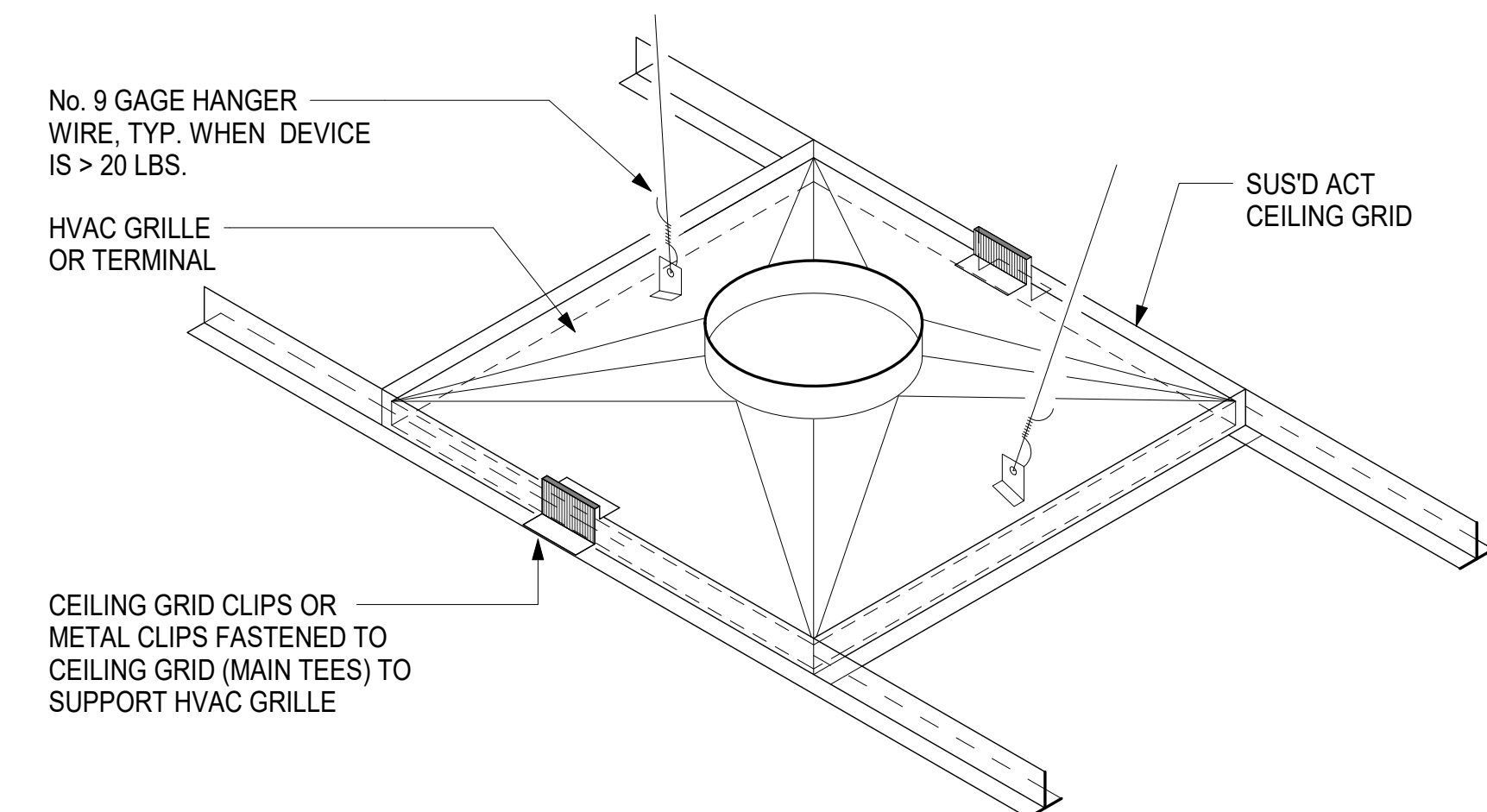

4 AIR TERMINAL ATTACHMT TO SUSP'D GRID

A560 SCALE: 1/8" = 1'-0"

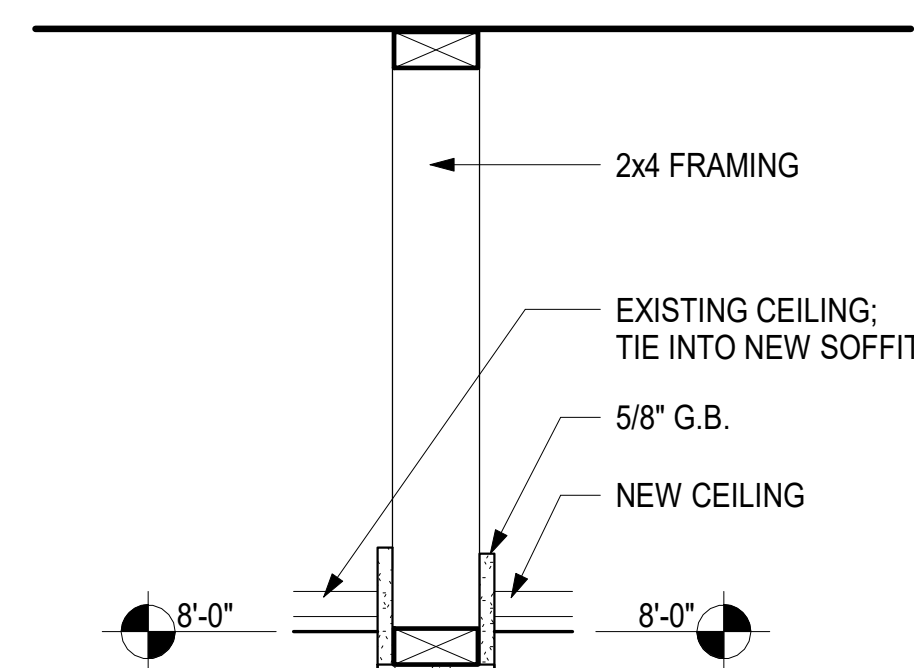

3 CEILING DETAIL

A560 SCALE: 1 1/2" = 1'-0"

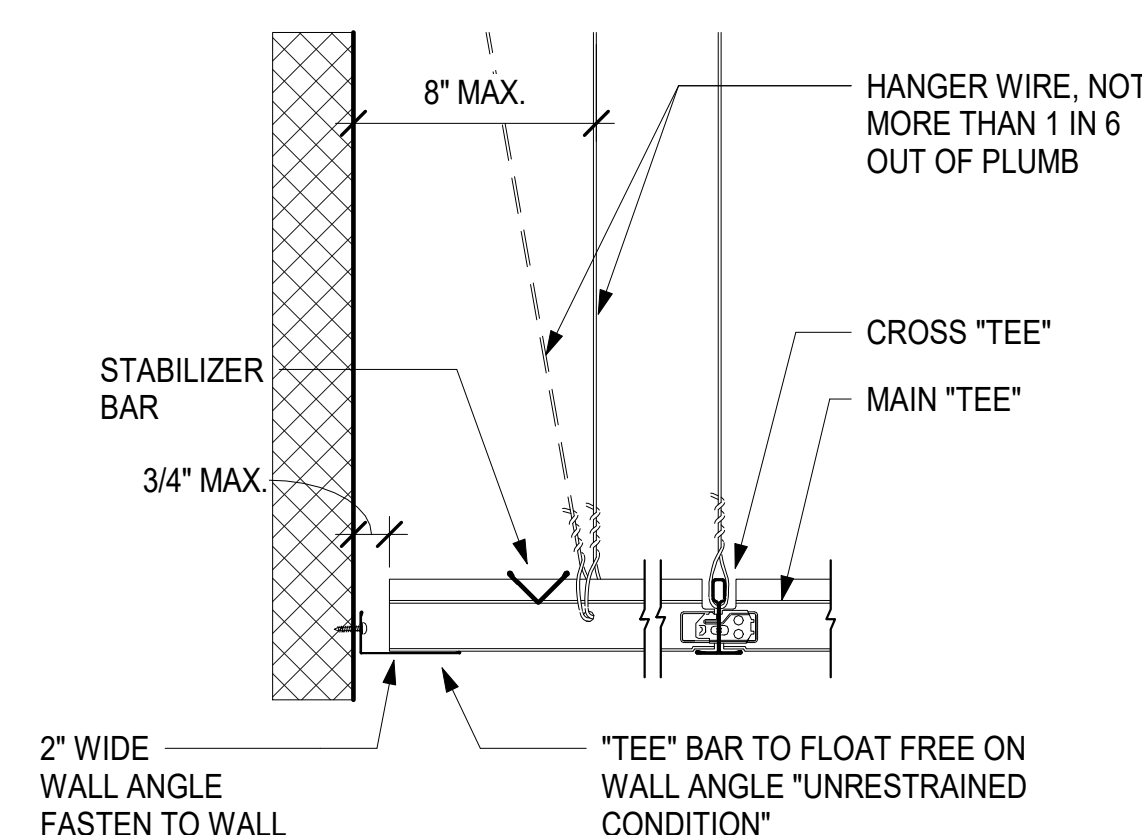

2 UNRESTRAINED GRID / WALL

A560 SCALE: 3" = 1'-0"

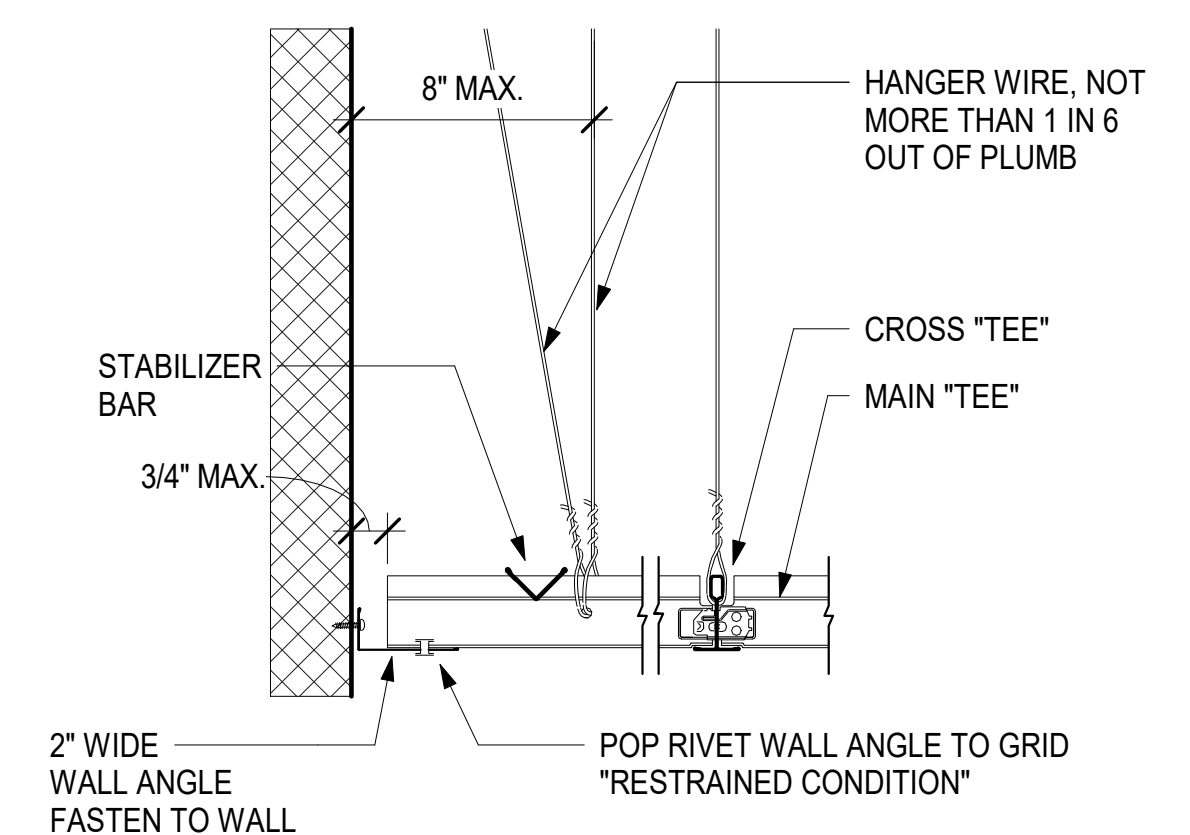

1 ACT GRID AT WALL

A560 SCALE: 3" = 1'-0"

| REV# | DATE | DESCRIPTION |
|------|------|-------------|
| | | |
| | | |
| | | |
| | | |



**HARRELSON BUILDING
IT DEPARTMENT
RENOVATION**
COLLETON COUNTY
31 KLEIN STREET,
WALTERBORO, SC 29464

COPYRIGHT © GLICK/BOEHM & ASSOCIATES, INC.
JOB NUMBER: 1924
PROJECT MGR.: MCM
DRAWN BY: MCM
CHECKED BY: SM
APPROVED BY: GB
DATE ISSUED FOR: CD SET 11/04/22

**INTERIOR RCP
DETAILS**

A560

| REV. | DATE | DESCRIPTION |
|------|------|-------------|
| | | |
| | | |
| | | |
| | | |
| | | |
| | | |
| | | |
| | | |
| | | |

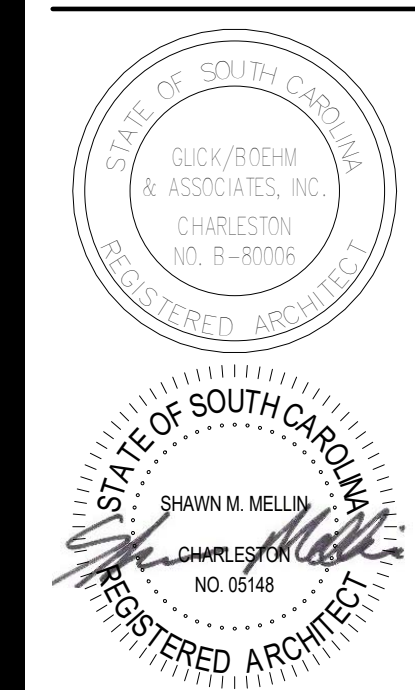

**HARRELSON BUILDING
IT DEPARTMENT
RENOVATION**
COLLETON COUNTY
31 KLEIN STREET,
WALTERBORO, SC 29464

COPYRIGHT © 2021
GLICK/BOEHM & ASSOCIATES, INC.
JOB NUMBER: 1924
PROJECT MGR.: MCM
DRAWN BY: MCM
CHECKED BY: SM
APPROVED BY: GB
DATE ISSUED FOR: CD SET 11/04/22

**FINISH & DOOR
SCHEDULE**

A600

| FINISH SCHEDULE PHASE 1 | | | | | | | | | | | | | |
|-------------------------|-----------|--------|------|-------|--------|-------|--------|-------|--------|-------|--------|---------|--------|
| ROOM NO. | ROOM NAME | FLOOR | | WALLS | | | | | | | | CEILING | |
| | | FINISH | BASE | NORTH | | EAST | | SOUTH | | WEST | | MTRL. | FINISH |
| | | | | MTRL. | FINISH | MTRL. | FINISH | MTRL. | FINISH | MTRL. | FINISH | | |
| 108 | STORAGE | VCT | RB-1 | CMU | PNT-1 | CMU | PNT-1 | CMU | PNT-1 | CMU | PNT-1 | ACT-1 | |
| 109 | IT OFFICE | CPT-1 | RB-1 | CMU | PNT-1 | CMU | PNT-1 | CMU | PNT-1 | CMU | PNT-1 | ACT-1 | - |

| FINISH SCHEDULE PHASE 2 | | | | | | | | | | | | | |
|-------------------------|----------------|--------------|------|-------|--------|-------|--------|-------|--------|-------|--------|---------|--------|
| ROOM NO. | ROOM NAME | FLOOR | | WALLS | | | | | | | | CEILING | |
| | | FINISH | BASE | NORTH | | EAST | | SOUTH | | WEST | | MTRL. | FINISH |
| | | | | MTRL. | FINISH | MTRL. | FINISH | MTRL. | FINISH | MTRL. | FINISH | | |
| 11 & 12 | HALLWAY | LVT | RB-1 | CMU | PNT-1 | CMU | PNT-1 | CMU | PNT-1 | CMU | PNT-1 | ACT-1 | - |
| 111 | IT DATA CENTER | R.F.S. / VCT | RB-1 | CMU | PNT-1 | CMU | PNT-1 | CMU | PNT-1 | CMU | PNT-1 | - | - |
| 115A | ROD: PUBLIC | LVT | RB-1 | - | - | - | - | - | - | - | - | - | - |

| FINISH SCHEDULE PHASE 3 | | | | | | | | | | | | | |
|-------------------------|--------------------------|--------|------|--------|--------|--------|--------|--------|--------|--------|--------|---------|--------|
| ROOM NO. | ROOM NAME | FLOOR | | WALLS | | | | | | | | CEILING | |
| | | FINISH | BASE | NORTH | | EAST | | SOUTH | | WEST | | MTRL. | FINISH |
| | | | | MTRL. | FINISH | MTRL. | FINISH | MTRL. | FINISH | MTRL. | FINISH | | |
| 100 | RODS: PUBLIC RECORDS | CPT-1 | RB-1 | CMU | PNT-1 | CMU | PNT-1 | CMU | PNT-1 | CMU | PNT-1 | ACT-1 | |
| 103 | REGISTER OF DEEDS | CPT-1 | RB-1 | CMU | PNT-1 | CMU | PNT-1 | CMU | PNT-1 | CMU | PNT-1 | ACT-1 | |
| 103A | VAULT | CPT-1 | RB-1 | CMU | PNT-1 | CMU | PNT-1 | CMU | PNT-1 | CMU | PNT-1 | CONC | PNT-2 |
| 104 | WOMENS | EXIST. | - | CMU(1) | PNT-1 | CMU(1) | PNT-1 | CMU(1) | PNT-1 | CMU(1) | PNT-1 | ACT-1 | |
| 113 | HANDICAP | EXIST. | - | CMU(1) | PNT-1 | CMU(1) | PNT-1 | CMU(1) | PNT-1 | CMU(1) | PNT-1 | ACT-1 | |
| 114 | MENS | EXIST. | - | CMU(1) | PNT-1 | CMU(1) | PNT-1 | CMU(1) | PNT-1 | CMU(1) | PNT-1 | ACT-1 | |
| 115 | ROD: RECORDING | CPT-1 | RB-1 | CMU | PNT-1 | CMU | PNT-1 | CMU | PNT-1 | CMU | PNT-1 | ACT-1 | |
| 115A | ROD: PUBLIC | - | - | CMU | PNT-1 | CMU | PNT-1 | - | - | CMU | PNT-1 | ACT-1 | |
| 116 | CLERK | CPT-1 | RB-1 | CMU | PNT-1 | CMU | PNT-1 | CMU | PNT-1 | CMU | PNT-1 | ACT-1 | |
| 117 | DIRECTOR | CPT-1 | RB-1 | CMU | PNT-1 | CMU | PNT-1 | CMU | PNT-1 | CMU | PNT-1 | ACT-1 | |
| 119 | REGISTER OF DEEDS: PLATS | CPT-1 | RB-1 | CMU* | PNT-4 | CMU* | PNT-4 | GYP. | PNT-1 | CMU* | PNT-4 | ACT-1 | |
| 120 | OFFICE | CPT-1 | RB-1 | CMU | PNT-1 | CMU | PNT-1 | GYP. | PNT-1 | CMU | PNT-1 | ACT-1 | |
| 122/123 | OPEN OFFICE | CPT-1 | RB-1 | GYP. | PNT-1 | GYP. | PNT-1 | GYP. | PNT-1 | GYP. | PNT-1 | ACT-1 | |
| 124 | STORAGE | CPT-1 | RB-1 | CMU | PNT-1 | CMU | PNT-1 | CMU | PNT-1 | CMU | PNT-1 | ACT-1 | |

(1) ABOVE 6 FOOT EXISTING C.T. WAINSCOT * UNFINISHED CMU

| DOOR & FRAME SCHEDULE PHASE 1 | | | | | | | | | | | | | |
|-------------------------------|------|--------|-------|-----------|----------|--------|---------|-------|----------|--------|-------------|--------------|-----------------------------------|
| TAG | DOOR | | | | | | | FRAME | | | FIRE RATING | HARDWARE SET | NOTES |
| | TYPE | HEIGHT | WIDTH | THICKNESS | MATERIAL | FINISH | GLAZING | TYPE | MATERIAL | FINISH | | | |
| 109 | -- | 7'-0" | 3'-0" | 1 3/4" | SCW | -- | -- | -- | HM | PNT | | 01 | EXISTING DOOR + FRAME, SEE NOTE 1 |

| DOOR & FRAME SCHEDULE PHASE 2 | | | | | | | | | | | | | |
|-------------------------------|------|--------|-------|-----------|----------|--------|---------|-------|----------|--------|-------------|--------------|----------------------------|
| TAG | DOOR | | | | | | | FRAME | | | FIRE RATING | HARDWARE SET | NOTES |
| | TYPE | HEIGHT | WIDTH | THICKNESS | MATERIAL | FINISH | GLAZING | TYPE | MATERIAL | FINISH | | | |
| 108 | D3 | 7'-10" | 4'-0" | 1 3/4" | ALUM | CLR | TEMP | F2 | ALUM | CLR | | 02 | ACCESS CONTROL |
| 110 | D1 | 6'-8" | 4'-0" | 1 3/4" | SCW | PNT | | F1 | HM | PNT | | 03 | ACCESS CONTROL |
| 112 | D1 | 6'-8" | 3'-0" | 1 3/4" | SCW | -- | -- | EXIST | HM | PNT | 1-HR | 04 | EXISTING FRAME, SEE NOTE 1 |
| 121 | D1 | 6'-8" | 6'-0" | 1 3/4" | SCW | PNT | -- | EXIST | HM | PNT | | 05 | EXISTING FRAME, SEE NOTE 1 |

| DOOR & FRAME SCHEDULE PHASE 3 | | | | | | | | | | | | | |
|-------------------------------|------|--------|-------|-----------|----------|--------|---------|-------|----------|--------|-------------|--------------|----------------------------|
| TAG | DOOR | | | | | | | FRAME | | | FIRE RATING | HARDWARE SET | NOTES |
| | TYPE | HEIGHT | WIDTH | THICKNESS | MATERIAL | FINISH | GLAZING | TYPE | MATERIAL | FINISH | | | |
| 120 | D2 | 6'-8" | 3'-0" | 1 3/4" | SCW | -- | -- | -- | HM | PNT | | 06 | EXISTING FRAME, SEE NOTE 1 |
| 122 | D1 | 6'-8" | 3'-0" | 1 3/4" | SCW | -- | -- | -- | HM | PNT | | 06 | EXISTING FRAME, SEE NOTE 1 |
| 123 | D1 | 6'-8" | 3'-0" | 1 3/4" | SCW | -- | -- | -- | HM | PNT | | 06 | EXISTING FRAME, SEE NOTE 1 |

NOTES:
1. ACCESS CONTROL PROVIDED BY OWNER - COORDINATE DOORS & FRAME PREPARATION WITH OWNER'S CONTRACTOR.

RAISED FLOORING SYSTEMS (RFS)

Manufacturers
A. Subject to compliance with requirements, provide access flooring by ASM Modular Systems, Inc., consisting of FS200 access floor panels supported on a bolted stringer understructure.
B. The access floor shall be the FS200 panel with a 4x4 rigid grid stringer system installed in a basket weave configuration manufactured by ASM Modular Systems, Inc. or approved equal.
C. Cementitious - Filled, Formed-Steel Panels: Fabricate panels with a die formed all-steel bottom pan, fully welded to a die-cut full-hard steel top sheet to form a structural unitized construction. Completed panels to be filled with light-weight cementitious fill. Concentrated load shall be 1250lb on 1 square inch at the weakest point allowing no more than 0.100" deflection per CISC standards.
D. Understructure shall be hot dipped galvanized or nickel chrome coated to ensure no zinc whiskering.

Submittals
A. Product Data: For each type of product indicated.
1. Shop Drawings: Include complete layout of access flooring system based of field verified dimensions.
a. Details and sections with descriptive notes indicating materials, finishes, fasteners, typical and special edge conditions, accessories and understructure.
b. Detail Cut Sheets for each type of product indicated, including accessories, to show the information necessary to make a full evaluation of the entire flooring systems.
c. For installed products indicated to comply with seismic design loads, include calculated structural analysis data signed by the qualified engineer responsible for their preparation.
2. Samples: For each type of flooring material indicated and exposed finish indicated, submit samples in the form of manufacturers color charts consisting of actual units or sections of units showing full range of colors, textures, and patterns.

Seismic Data
Sds = 0.584g
Sdi = 0.294g
SEISMIC IMPORTANCE FACTOR: 1.00
D
SEISMIC DESIGN CATEGORY: R = 6.50
LATERAL FORCE RESISTING SYSTEM: Ω = 2.50
Cd = 4.00

FINISH LEGEND NOTES

| | |
|---|---|
| 1 | ALL WALLS TO BE PAINTED INSTITUTIONAL, LOW VOC EGGSHELL FINISH. |
| 2 | ALL CEILINGS TO BE PAINTED INSTITUTIONAL, LOW VOC, FLAT FINISH. |

DOOR SCHEDULE NOTES

| | |
|---|---|
| 1 | REFER TO DOOR PANEL TYPES FOR GLAZING TYPES AND LOCATIONS |
|---|---|

FINISH ABBREVIATIONS

| | |
|--------|--|
| ACT | ACOUSTICAL CEILING TILE |
| ACW | ALUMINUM CLAD WOOD |
| ALUM | ALUMINUM |
| CONC. | CONCRETE |
| CPT | CARPET |
| CT | CERAMIC TILE |
| EXT | EXISTING FLOORING FINISH |
| FF | FACTORY FINISH |
| GYP BD | GYPSUM BOARD |
| MFR | MANUFACTURER FINISH |
| OTS | OPEN TO STRUCTURE |
| PNT | PAINT |
| RFS | RAISED FLOORING SYSTEM, REFER TO PLANS FOR EXTENTS |
| SCW | SOLID CORE (WOOD DOOR) |
| ST | STAIN (FACTORY FINISH) |
| WC | WAINSCOT |
| WD | WOOD |

MATERIAL AND FINISH LEGEND

| TAG | LOCATION | FINISH/SIZE | MANUFACTURER | COLOR |
|-------|------------------|--|----------------|---------------|
| PNT-1 | WALLS | SATIN | BENJAMIN-MOORE | BY OWNER |
| PNT-2 | SOFFITS | FLAT | BENJAMIN-MOORE | BY OWNER |
| PNT-3 | FRAMES | SEMI-GLOSS | BENJAMIN-MOORE | BY OWNER |
| PNT-4 | UNFINISHED WALLS | BLOCK FILLER, PRIMER, 2 COATS OF SATIN PAINT | | |
| RB-1 | BASE | 4" COVE | ROPPE | BY OWNER |
| LVT-1 | FLOOR | 6" X 48" X 1/8" | FLEXCO | BY OWNER |
| VCT-1 | FLOOR | 12" X 12" | ARMSTRONG | BY OWNER |
| CPT-1 | FLOOR | 1m X 1m CARPET TILE | MILLIKEN | BY OWNER |
| ACT-1 | CEILINGS | 2'X4'X1" SQ EDGE | USG | 87200 - WHITE |

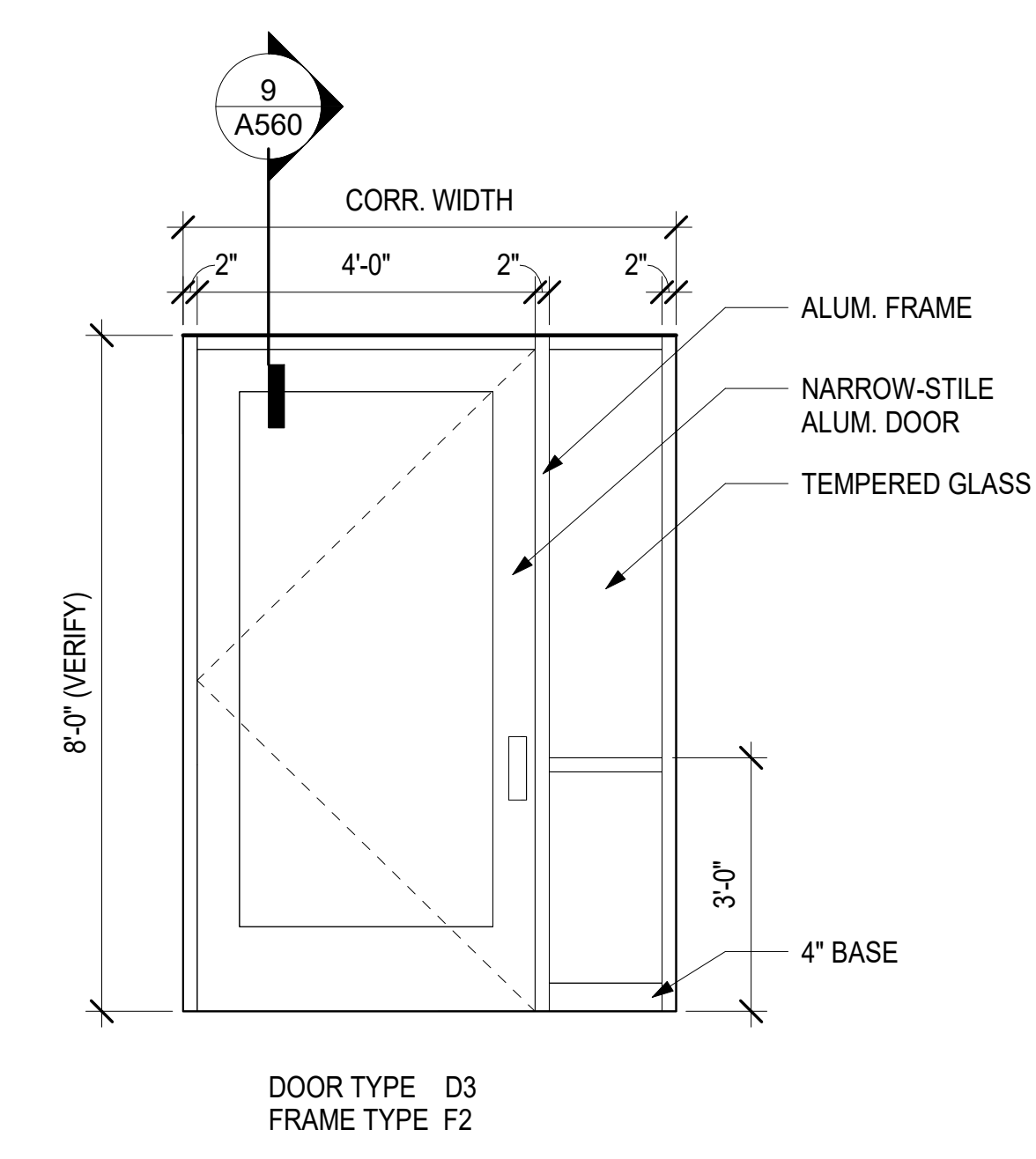

1 STOREFRONT DOOR
SCALE: 1/2" = 1'-0"

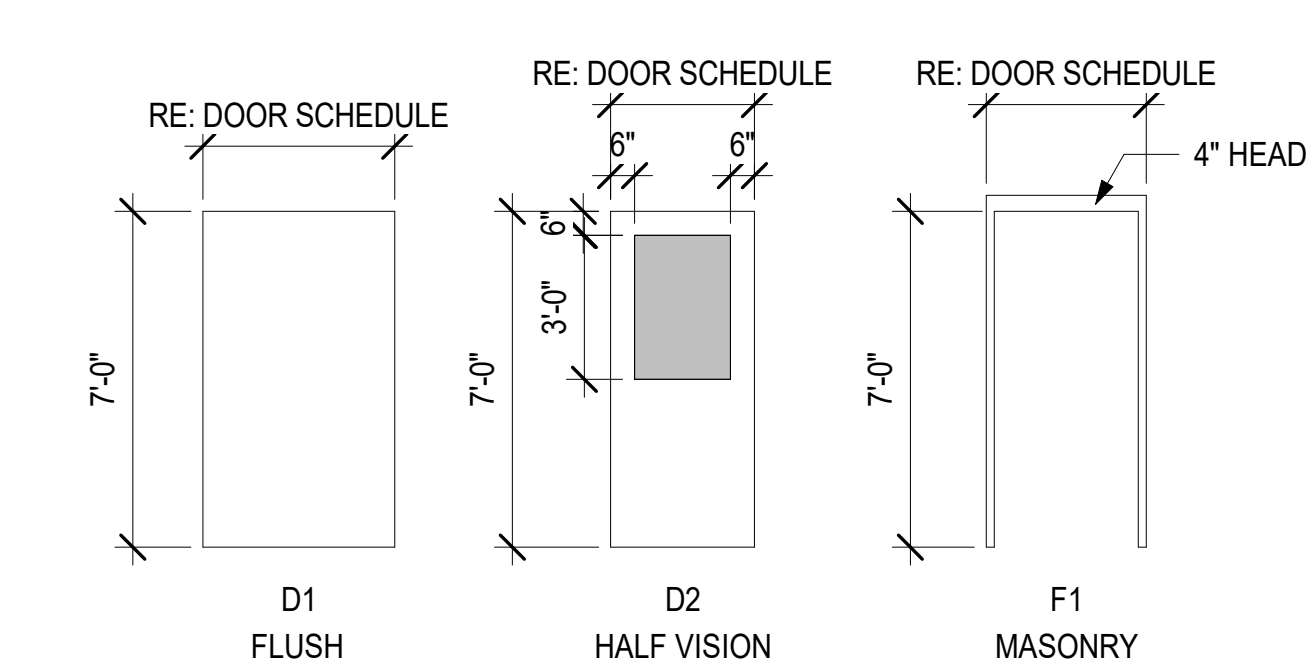

DOOR TYPE & FRAME ELEVATIONS
SCALE: 1/4" = 1'-0"

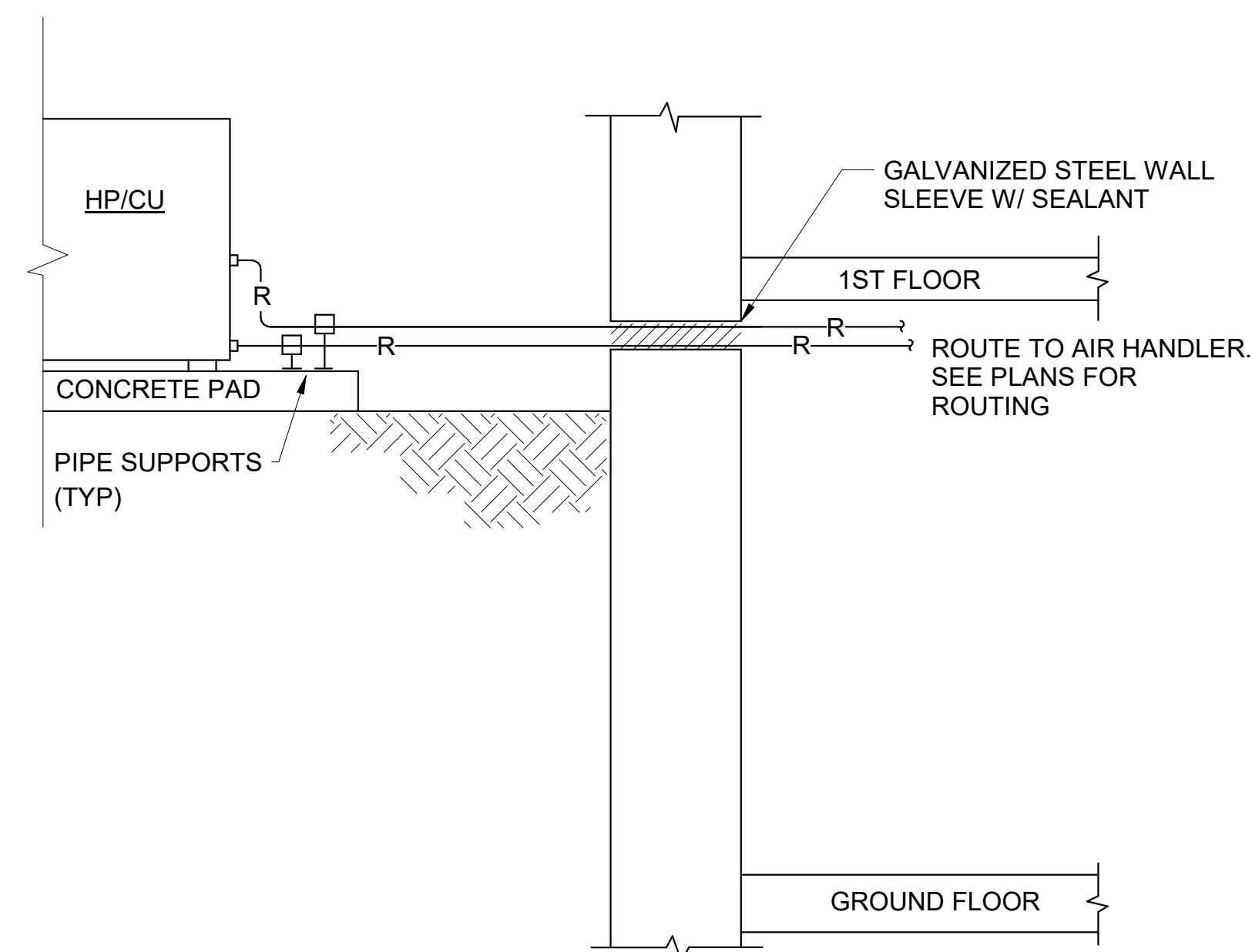

NOTES:

- ALL PIPING SHALL BE HARD DRAWN COPPER TUBING WITH SOLDERED JOINTS.
- EXTERIOR REFRIGERANT LINES SHALL BE PROVIDED WITH ALUMINUM JACKET.

1 SPLIT SYSTEM INSTALLATION DETAIL
MP002 SCALE: NOT TO SCALE

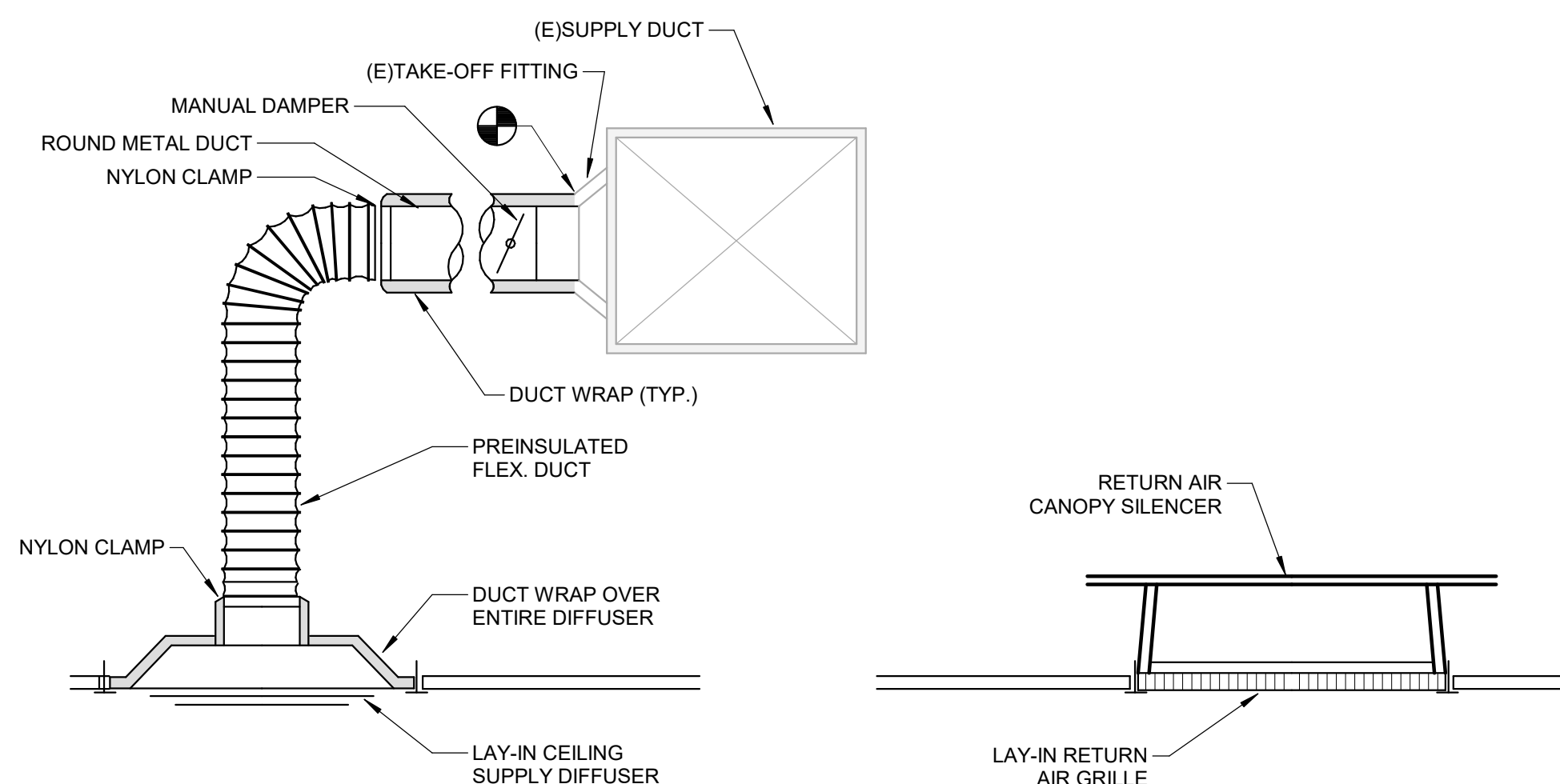

NOTES:

- INSTALL NYLON CLAMPS ON INNER FLEX DUCT LINER AND OUTER JACKET. TAPE ENDS OF PREINSULATED FLEX. DUCT AT THE DIFFUSER AND THE BRANCH DUCT CONNECTION.

3 TYPICAL DIFFUSER/GRILLE INSTALLATION DETAIL
MP002 SCALE: NOT TO SCALE

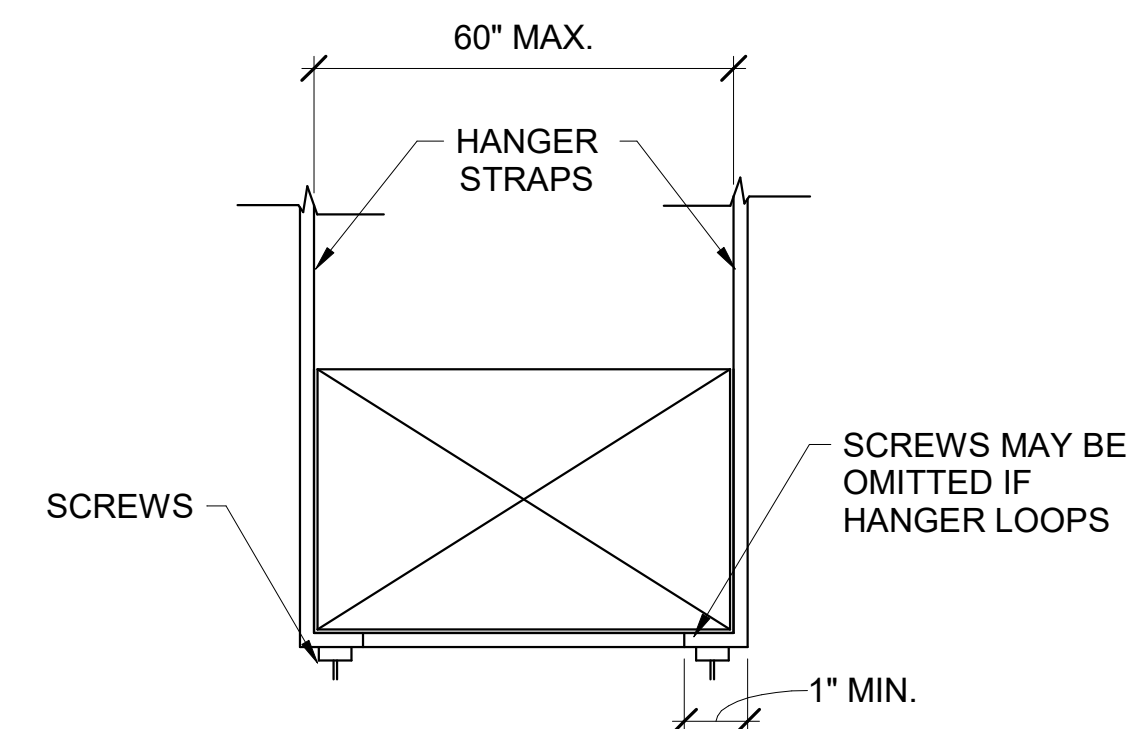

| TABLE 4-1 RECTANGULAR DUCT HANGERS MINIMUM SIZE | | | | | | | | |
|---|---------------------------|---|-----------------------|----------------|--|----------------|----------------------|----------------|
| MAXIMUM HALF OF DUCT PERIMETER | PAIR AT 10 FT. SPACING | | PAIR AT 8 FT. SPACING | | PAIR AT 5 FT. SPACING | | PAIR AT 4FT. SPACING | |
| | STRAP | WIRE/ROD | STRAP | WIRE/ROD | STRAP | WIRE/ROD | STRAP | WIRE/ROD |
| P/2= 30" | 1" X 22 GA. | 10 GA. (.135") | 1" X 22 GA. | 10 GA. (.135") | 1" X 22 GA. | 12 GA. (.106") | 1" X 22 GA. | 12 GA. (.106") |
| P/2= 72" | 1" X 18 GA. | 3/8" | 1" X 20 GA. | 1/4" | 1" X 22 GA. | 1/4" | 1" X 22 GA. | 1/4" |
| P/2= 96" | 1" X 16 GA. | 3/8" | 1" X 18 GA. | 3/8" | 1" X 20 GA. | 3/8" | 1" X 22 GA. | 1/4" |
| P/2= 120" | 1-1/2" X 16 GA. | 1/2" | 1" X 16 GA. | 3/8" | 1" X 18 GA. | 3/8" | 1" X 20 GA. | 1/4" |
| P/2= 168" | 1-1/2" X 16 GA. | 1/2" | 1-1/2" X 16 GA. | 1/2" | 1" X 16 GA. | 3/8" | 1" X 18 GA. | 3/8" |
| P/2= 192" | NOT GIVEN | 1/2" | 1-1/2" X 16 GA. | 1/2" | 1" X 16 GA. | 3/8" | 1" X 16 GA. | 3/8" |
| P/2=193" UP | SPECIAL ANALYSIS REQUIRED | | | | | | | |
| WHEN STRAPS ARE LAP JOINED, USE THESE MINIMUM FASTENERS 1" X 18, 20, 22 GA. - TWO #10 OR ONE 1/4" BOLT 1" X 16 GA. - TWO 1/4" DIA. 1-1/2" X 16 GA. - TWO 3/8" DIA. PLACE FASTENERS IN SERIES, NOT SIDE BY SIDE. | | SINGLE HANGER MAXIMUM ALLOWABLE LOAD | | | | | | |
| | | STRAP | | | WIRE OR ROD (DIA.) | | | |
| | | 1" X 22 GA. - 260 LBS. 1" X 20 GA. - 320 LBS. 1" X 18 GA. - 420 LBS. 1" X 16 GA. - 700 LBS. 1-1/2" X 16 GA. - 1100 LBS. | | | 1/4"-270 LBS. 3/8"-680 LBS. 1/2"-1250 LBS. 5/8"-2000 LBS. 3/4"-3000 LBS. | | | |

2 SUPPORT DETAIL
MP002 SCALE: NOT TO SCALE

NOTES:

- LOCATE TRAPS SO AS TO BE ACCESSIBLE FOR CLEANING.
- "RUNNING" TYPE TRAPS SHALL BE UNACCEPTABLE.
- H = TOTAL STATIC FAN PRESSURE (CONFIRM TSP WITH EQUIPMENT PROVIDED)
- J = H/2 (MINIMUM).

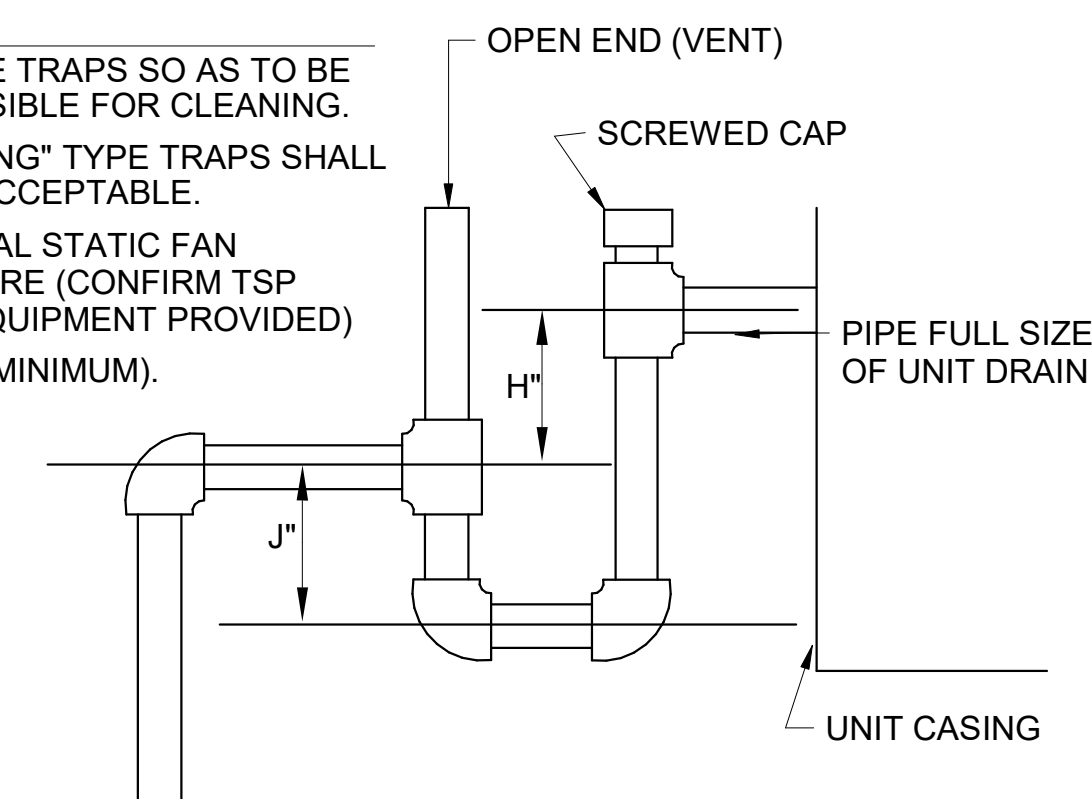

4 CONDENSATE DRAIN TRAP INSTALLATION DETAIL
MP002 NOT TO SCALE

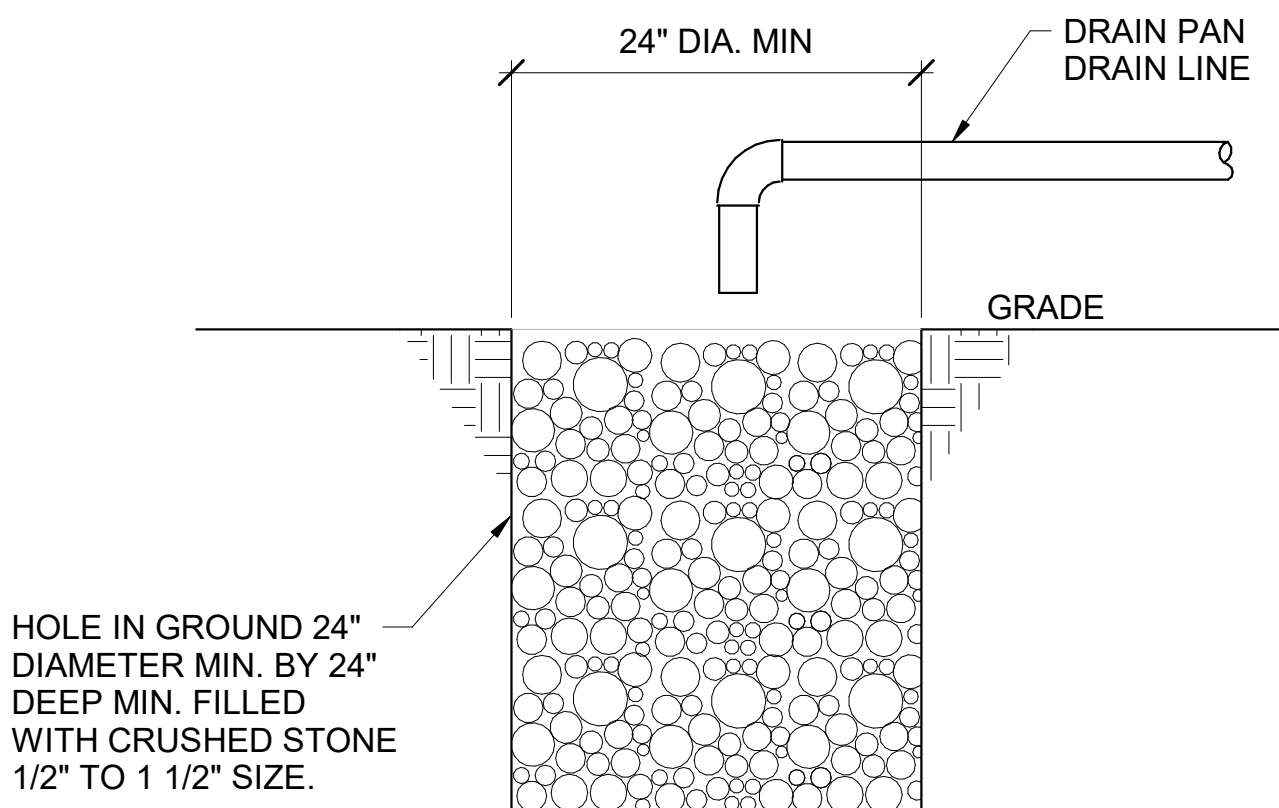

NOTES:

- COVER WITH LANDSCAPE AFTER INSPECTION IS COMPLETED.
- CONTRACTOR SHALL VERIFY THAT THE CONDENSATE DRAIN LINE IS IN WORKING ORDER BY RUNNING WATER DOWN THRU THE DRAIN LINE FROM THE POINT OF THE COIL CONNECTION PRIOR TO BURIAL.
- DRAIN PAN DRAIN LINE SHALL TERMINATE 6" ABOVE FINISHED GRADE OVER TOP OF THE DRAIN PIT.

5 CONDENSATE DRAIN PIT DETAIL
MP002 SCALE: NOT TO SCALE

| REV. | DATE | DESCRIPTION |
|------|------|-------------|
| | | |
| | | |
| | | |
| | | |
| | | |
| | | |
| | | |
| | | |
| | | |

DEMOLITION KEYNOTES

- 1 REMOVE DIFFUSER/GRILLE CAP THE ASSOCIATED DUCTWORK. NO REPLACEMENT AIR DEVICE IS NECESSARY.
- 2 REMOVE EXISTING DIFFUSER AND ASSOCIATED FLEX DUCT. PREPARE DUCT RUNOUT FOR NEW CONNECTION.

RENOVATION KEYNOTES

- 1 PROVIDE NEW DIFFUSER AND CONNECT WITH NEW FLEX DUCT. FIELD VERIFY THE PRESENCE OF AN EXISTING VOLUME DAMPER AND PROVIDE NEW IF THERE IS NOT ONE. SEE DETAIL.
- 2 PROVIDE A NEW PLENUM RETURN GRILLE WITH A PLENUM RETURN CANOPY SILENCER. BOD: PRICE MODEL RAC. SEE DETAIL.

GENERAL NOTES

- 1. PROVIDE NEW MANUAL BALANCING DAMPERS IN EACH BRANCH DUCT TO NEW DIFFUSERS. BALANCE THE NEW SUPPLY DIFFUSERS TO THE CFM INDICATED ON THE DRAWINGS.

LEGEND

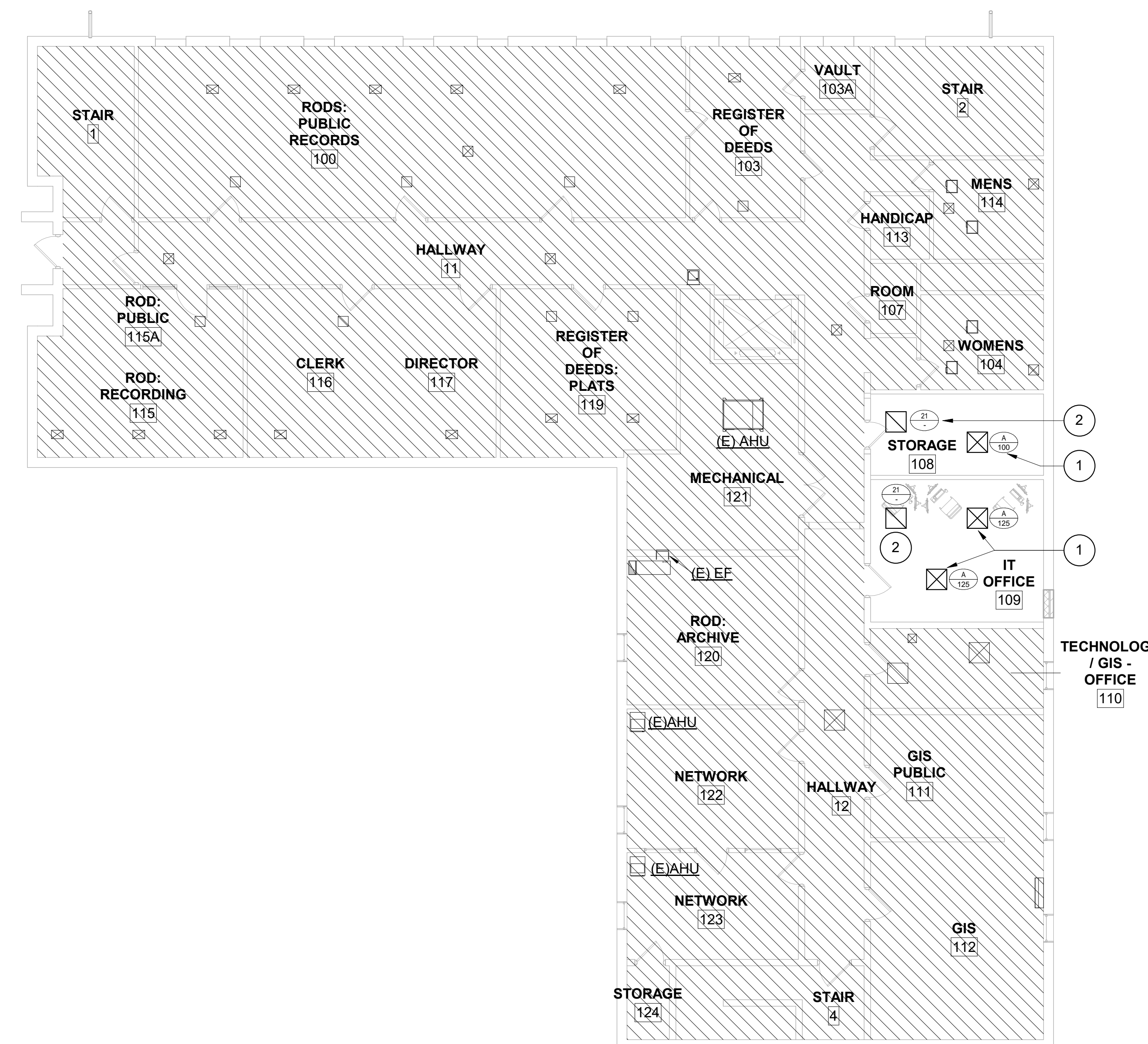
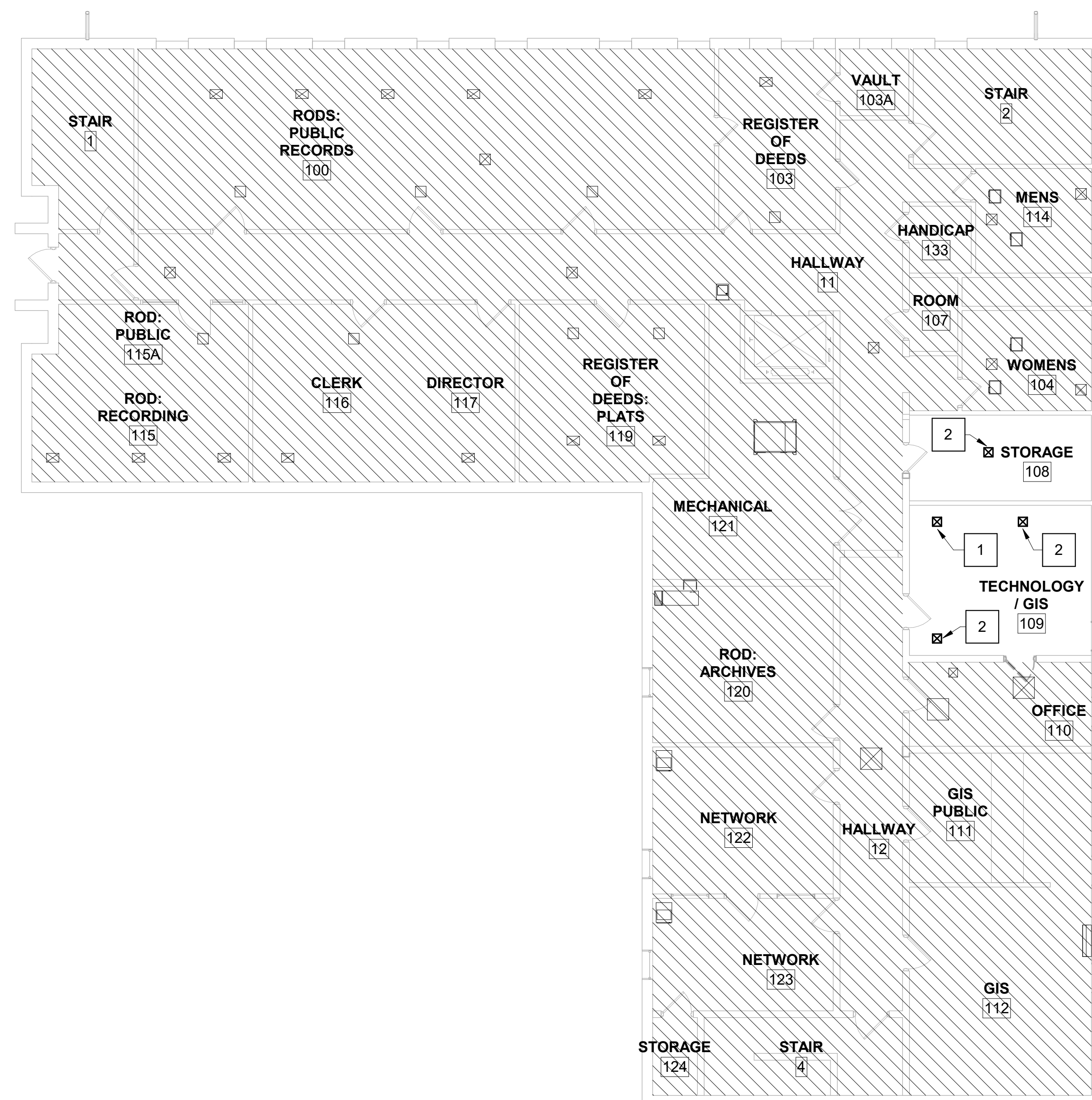
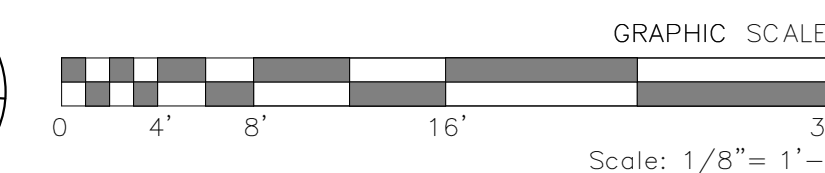
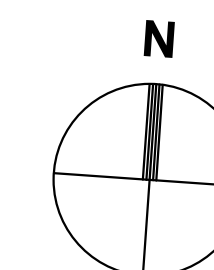

| REV. | DATE | DESCRIPTION |
|------|------|-------------|
| | | |
| | | |
| | | |
| | | |

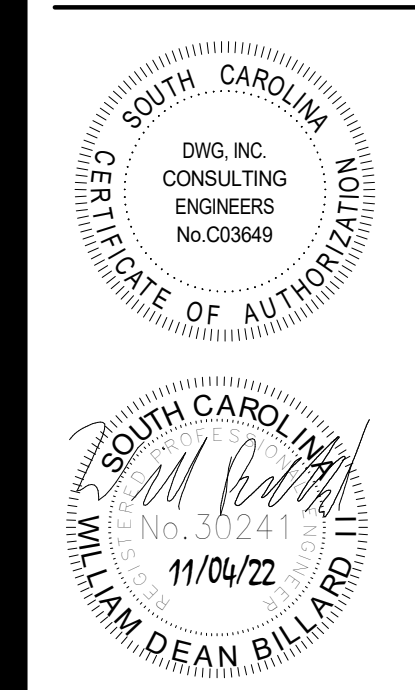

**HARRELSON BUILDING IT
DEPARTMENT
RENOVATION**
COLLETON COUNTY
31 KLEIN STREET,
WALTERBORO, SC 29488

COPYRIGHT © GLICK/BOEHM & ASSOCIATES, INC.
JOB NUMBER: 19138-00
DRAWN BY: CPM
CHECKED BY: WDB
APPROVED BY: WDB
DATE ISSUED FOR: CONSTRUCTION DOCUMENTS 11/04/22

**FIRST FLOOR
HVAC PLAN
(PHASE 1)**

MP100

1 FIRST FLOOR HVAC DEMOLITION PLAN - PHASE 1
MP100 SCALE: 1/8" = 1'-0"

2 FIRST FLOOR HVAC RENOVATION PLAN - PHASE 1
MP100 SCALE: 1/8" = 1'-0"

DEMOLITION KEYNOTES

- 1 REMOVE EXISTING AIR HANDLER, ASSOCIATED DUCTWORK, SUPPORTS, REFRIGERANT, AND CONDENSATE DRAIN.
- 2 REMOVE DIFFUSER/GRILLE CAP THE ASSOCIATED DUCTWORK. NO REPLACEMENT AIR DEVICE IS NECESSARY.
- 3 REMOVE EXISTING DIFFUSER AND ASSOCIATED FLEX DUCT. PREPARE DUCT RUNOUT FOR NEW CONNECTION.
- 4 DEMOLISH AND REMOVE WATER COOLER. PIPING SHALL REMAIN FOR RECONNECTION TO NEW WATER COOLER.

RENOVATION KEYNOTES

- 1 WALL MOUNTED CONTROLLER FOR LIEBERT UNITS. MOUNT AT 4' A.F.F.
- 2 CONDENSATE AND REFRIGERANT FROM THE CRAC UNITS SHALL BE ROUTED BELOW THE RAISED FLOOR AND CONNECT TO THE BOTTOM OF THE UNIT.
- 3 UNIT SHALL BE 4" OFF THE WALL IN THIS LOCATION IN ORDER TO MAINTAIN REAR SERVICE CLEARANCE. COORDINATE INSTALLATION AND WALL BLOCKING WITH THE GENERAL CONTRACTOR.
- 4 INSTALL UNITS AND ASSOCIATED PIPING PER THE MANUFACTURER'S INSTRUCTIONS. UNIT MOUNTING SHALL BE PER THE SEISMIC ENGINEER'S DELEGATED DESIGN.
- 5 PROVIDE NEW DIFFUSER AND CONNECT WITH NEW FLEX DUCT. FIELD VERIFY THE PRESENCE OF AN EXISTING VOLUME DAMPER AND PROVIDE NEW IF THERE IS NOT ONE. SEE DETAIL.
- 6 PROVIDE A NEW PLENUM RETURN GRILLE WITH A PLENUM RETURN CANOPY SILENCER. BOD: PRICE MODEL RAC. SEE DETAIL.
- 7 INSTALL NEW WATER COOLER CONNECT TO EXISTING PIPING. ELKAY LZS8WSLK OR EQUIVALENT. PROVIDE WATER COOLER WITH CANE APRON ACCESSORY. INSTALL TO MEET ADA REQUIREMENTS.

GENERAL NOTES

- 1. OUTDOOR HVAC EQUIPMENT SHALL BE MOUNTED ON A CONCRETE PAD. COORDINATE WITH THE GENERAL CONTRACTOR.

LEGEND

 AREA OUT OF SCOPE

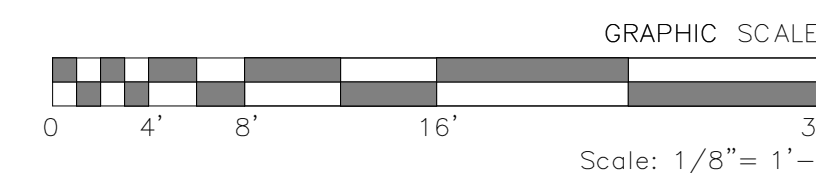
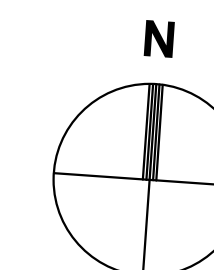

| REV. | DATE | DESCRIPTION |
|------|------|-------------|
| | | |
| | | |
| | | |
| | | |

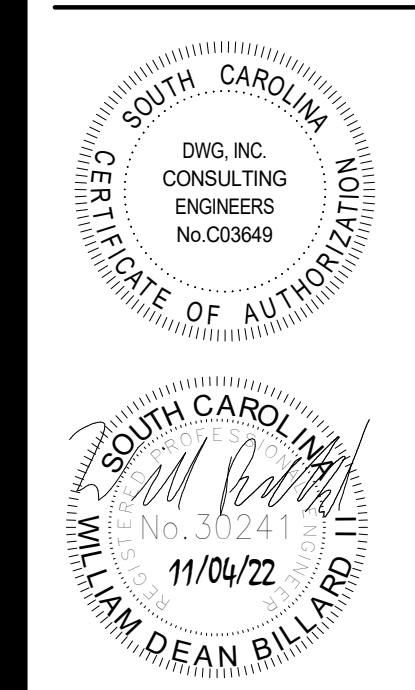

HARRELSON BUILDING IT DEPARTMENT RENOVATION
 COLLETON COUNTY
 31 KLEIN STREET,
 WALTERBORO, SC 29488

COPYRIGHT © GLICK/BOEHM & ASSOCIATES, INC.
 JOB NUMBER: 19138-00
 DRAWN BY: CPM
 CHECKED BY: WDB
 APPROVED BY: WDB
 DATE ISSUED FOR: CONSTRUCTION DOCUMENTS 11/04/22

FIRST FLOOR HVAC AND PLUMBING PLAN (PHASE 2)
MP200

1 FIRST FLOOR HVAC & PLUMBING DEMOLITION PLAN - PHASE 2
 MP200 SCALE: 1/8" = 1'-0"

2 FIRST FLOOR HVAC & PLUMBING RENOVATION PLAN - PHASE 2
 MP200 SCALE: 1/8" = 1'-0"

DEMOLITION KEYNOTES

- 1 REMOVE OUTDOOR CONDENSING UNIT AND ASSOCIATED REFRIGERANT PIPE. PATCH REFRIGERANT WALL PENETRATIONS TO MATCH EXISTING.
- 2 EXISTING EQUIPMENT TO REMAIN.

RENOVATION KEYNOTES

- 1 PROVIDE HVAC CONDENSATE DRAIN PIT AT GRADE. SEE DETAIL.
- 2 PROVIDE CONCRETE HOUSEKEEPING PAD FOR NEW CONDENSING UNITS.

GENERAL NOTES

- 1. OUTDOOR HVAC EQUIPMENT SHALL BE MOUNTED ON A CONCRETE PAD. COORDINATE WITH THE GENERAL CONTRACTOR.

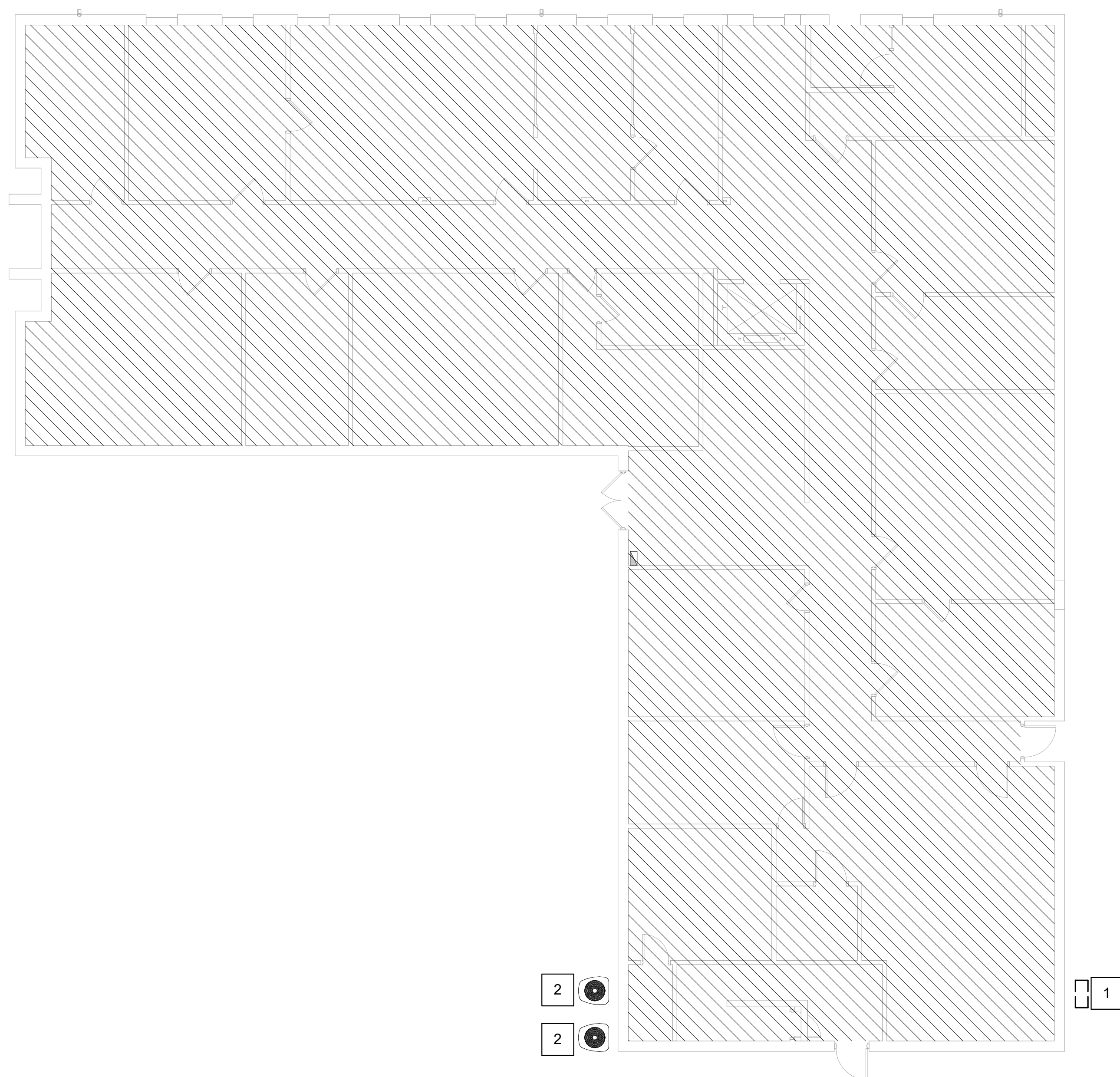
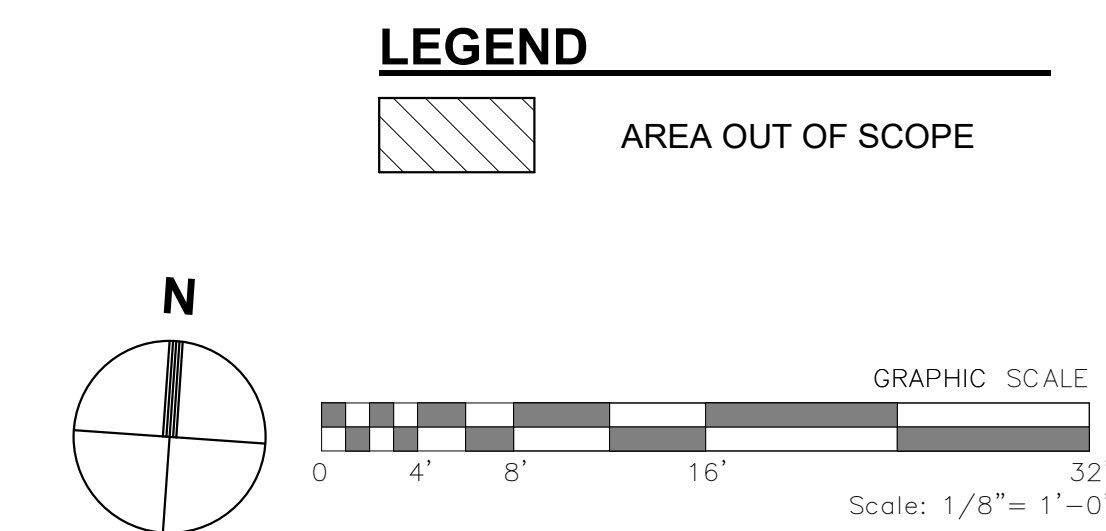

1 SECOND FLOOR HVAC DEMOLITION PLAN - PHASE 2
MP201 SCALE: 1/8" = 1'-0"

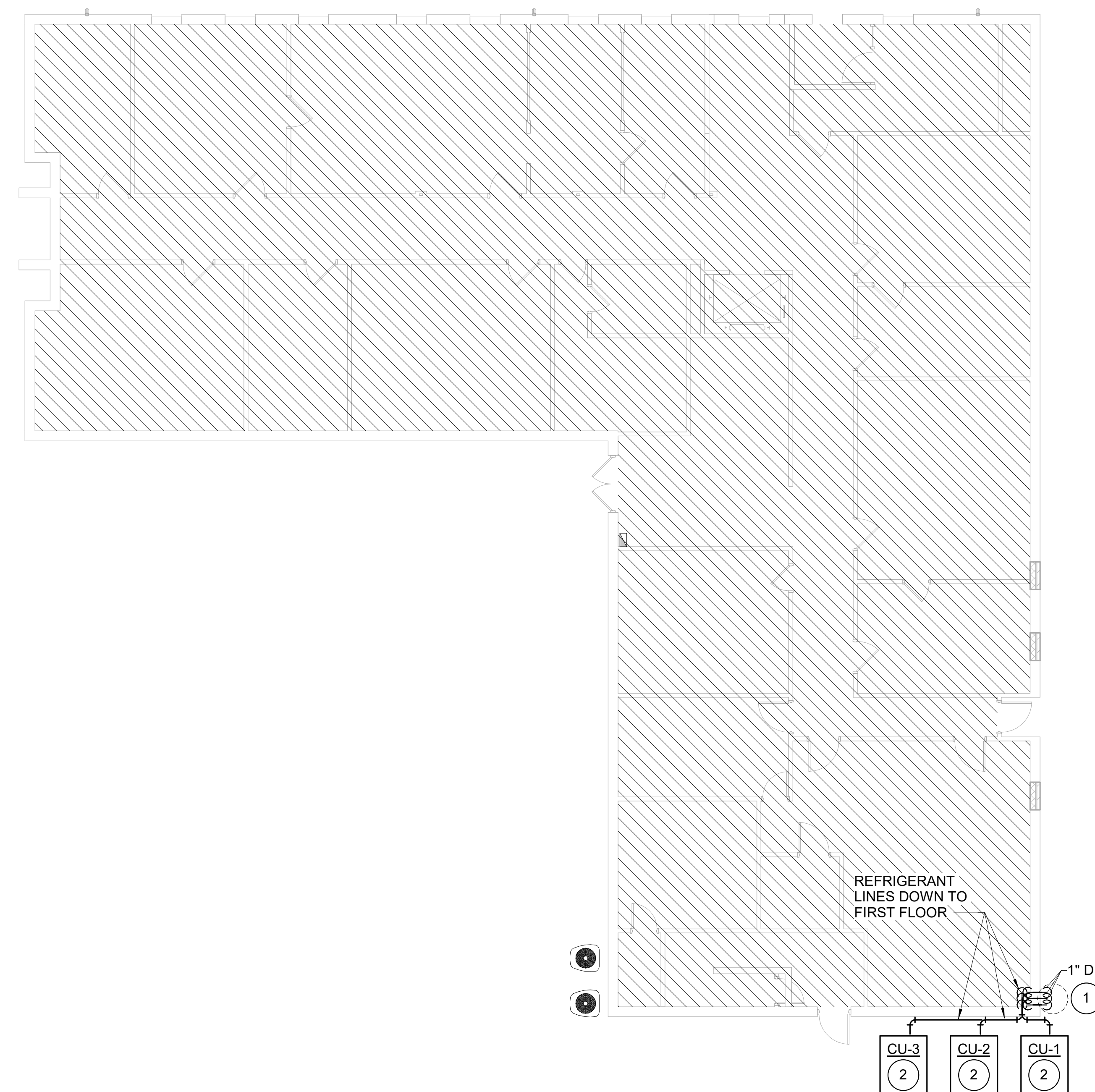

2 SECOND FLOOR HVAC RENOVATION PLAN - PHASE 2
MP201 SCALE: 1/8" = 1'-0"

| REV. | DATE | DESCRIPTION |
|------|------|-------------|
| | | |
| | | |
| | | |
| | | |

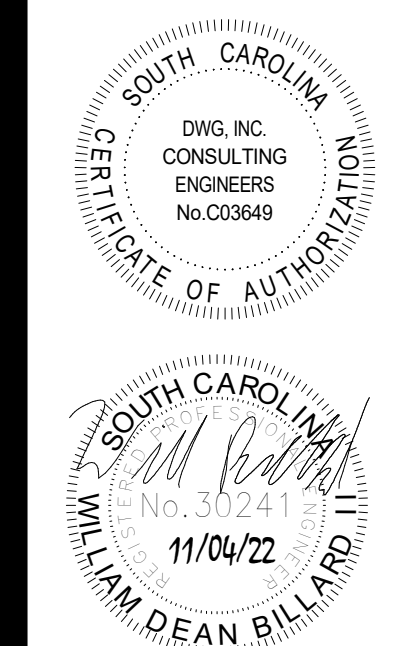

**HARRELSON BUILDING IT
DEPARTMENT
RENOVATION**
COLLETON COUNTY
31 KLEIN STREET,
WALTERBORO, SC 29488

COPYRIGHT © GLICK/BOEHM & ASSOCIATES, INC.
JOB NUMBER: 19138-00
DRAWN BY: CPM
CHECKED BY: WDB
APPROVED BY: WDB
DATE ISSUED FOR: CONSTRUCTION DOCUMENTS 11/04/22

SECOND FLOOR HVAC PLAN (PHASE 2)

MP201

DEMOLITION KEYNOTES

- 1 REMOVE EXISTING AIR HANDLER, ASSOCIATED DUCTWORK, SUPPORTS, REFRIGERANT, AND CONDENSATE DRAIN.
- 2 REMOVE EXISTING DIFFUSER AND ASSOCIATED FLEX DUCT. PREPARE DUCT RUNOUT FOR NEW CONNECTION.
- 3 REMOVE DIFFUSER/GRILLE CAP THE ASSOCIATED DUCTWORK. NO REPLACEMENT AIR DEVICE IS NECESSARY.
- 4 EXISTING EXHAUST FAN AND DUCTWORK TO REMAIN.
- 5 REMOVE EXHAUST FAN FROM CEILING DURING REPLACEMENT. RE-INSTALL THE FAN IN THE SAME LOCATION IN THE NEW CEILING AND RE-CONNECT TO THE EXISTING DUCTWORK AND CONTROLS.

RENOVATION KEYNOTES

- 1 PROVIDE NEW DIFFUSER AND CONNECT WITH NEW FLEX DUCT. FIELD VERIFY THE PRESENCE OF AN EXISTING VOLUME DAMPER AND PROVIDE NEW IF THERE IS NOT ONE. SEE DETAIL.
- 2 PROVIDE A NEW PLENUM RETURN GRILLE WITH A PLENUM RETURN CANOPY SILENCER. BOD: PRICE MODEL RAC. SEE DETAIL.

GENERAL NOTES

- 1. NEW DIFFUSERS AND GRILLES NOT TAGGED WITH A SPECIFIC AIRFLOW DO NOT NEED TO BE RE-BALANCED IN THE SCOPE OF THIS PROJECT, BUT THEY SHOULD BE PROVIDED WITH MANUAL BALANCING DAMPERS FOR FUTURE BALANCING IF NECESSARY.

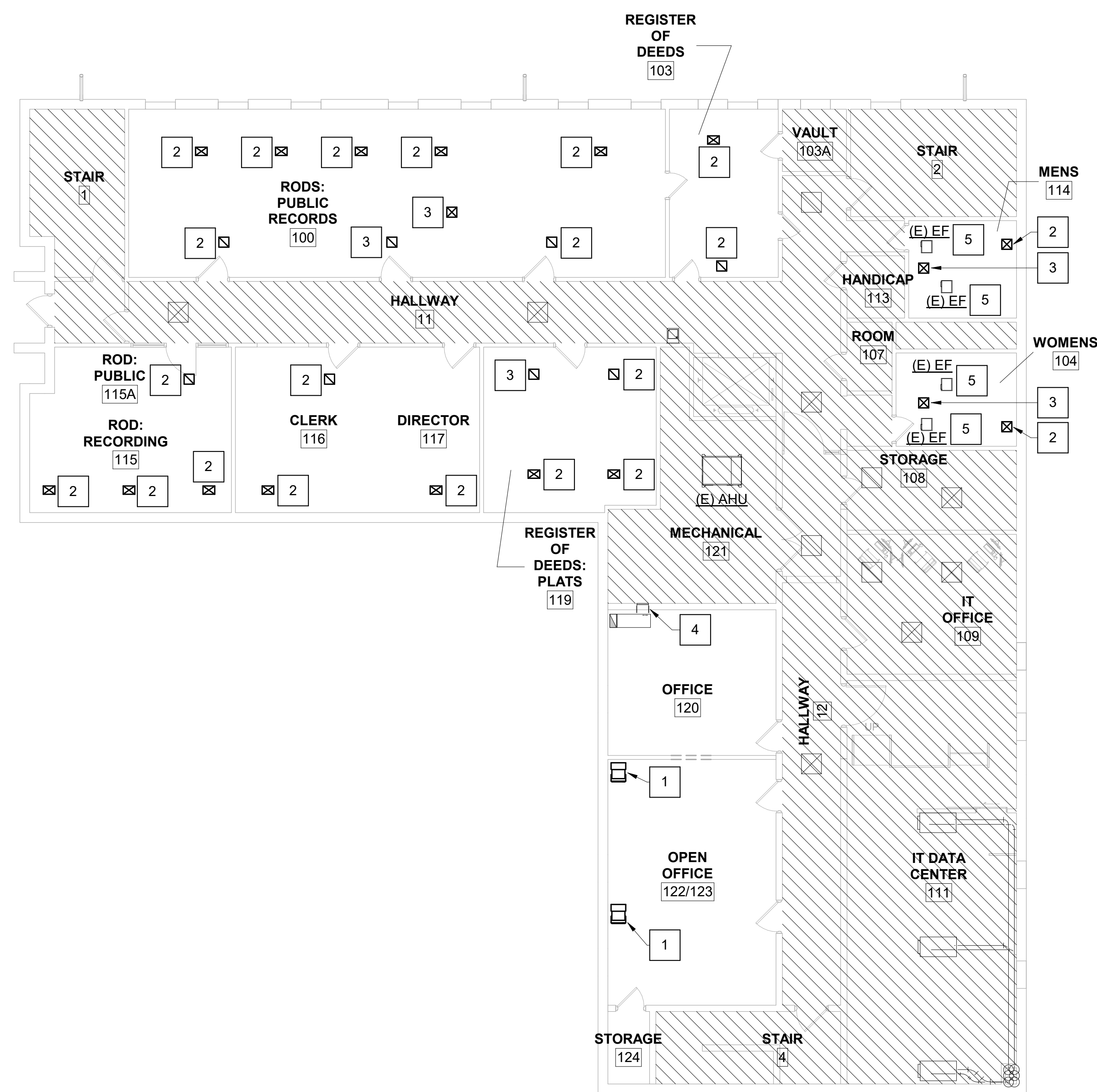
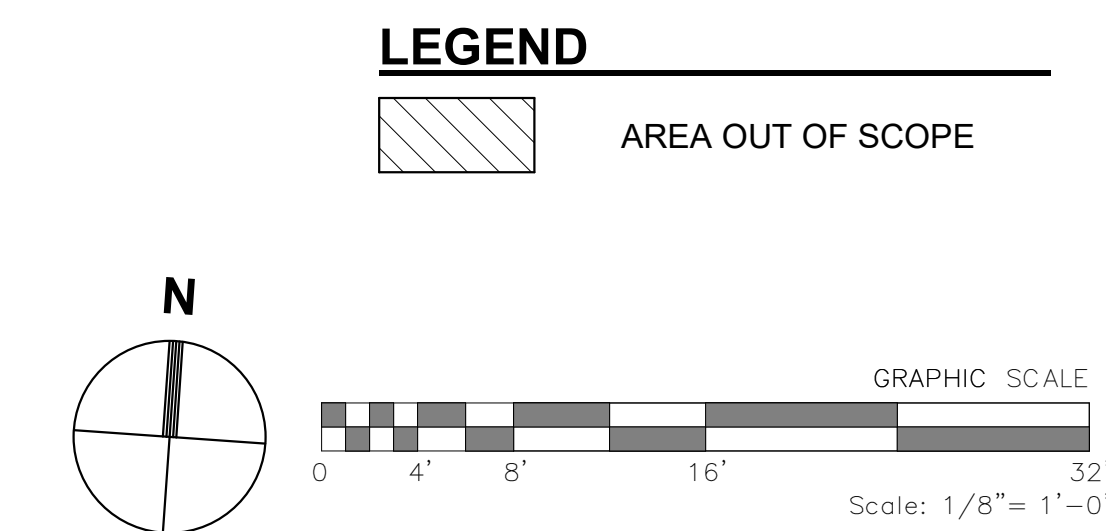

1 FIRST FLOOR HVAC DEMOLITION PLAN - PHASE 3
MP300 SCALE: 1/8" = 1'-0"

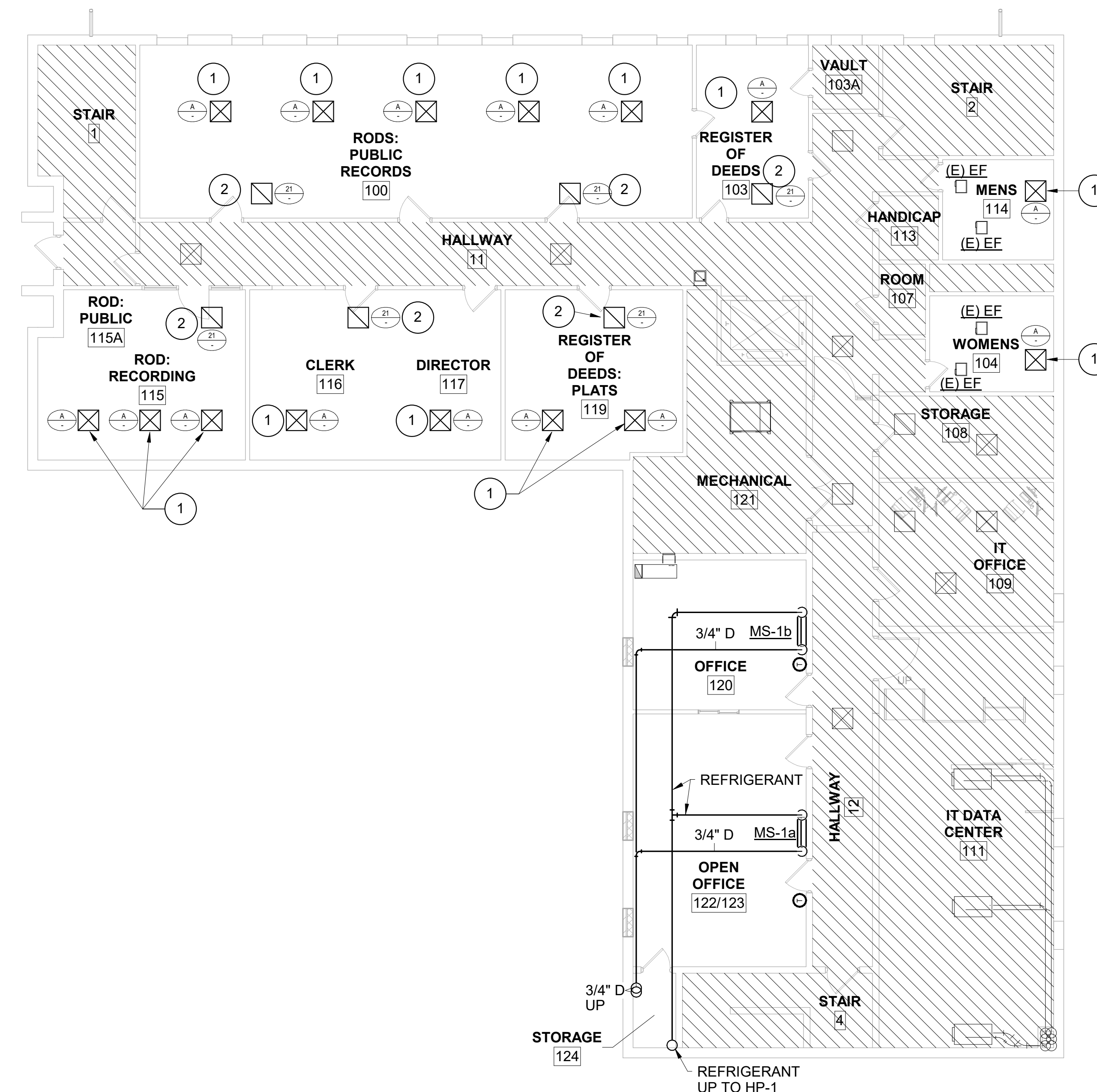

2 FIRST FLOOR HVAC RENOVATION PLAN - PHASE 3
MP300 SCALE: 1/8" = 1'-0"

| REV. | DATE | DESCRIPTION |
|------|------|-------------|
| | | |
| | | |
| | | |
| | | |

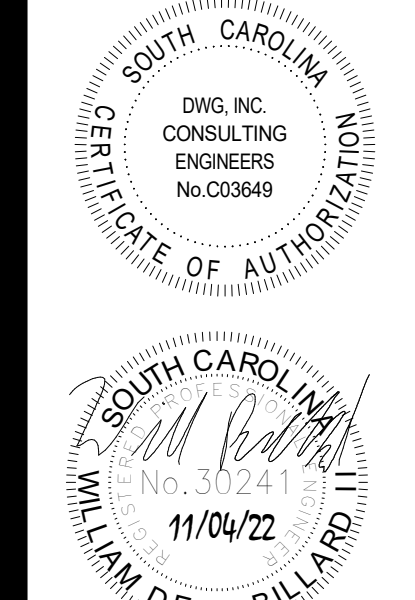

HARRELSON BUILDING IT DEPARTMENT RENOVATION
COLLETON COUNTY
31 KLEIN STREET,
WALTERBORO, SC 29488

COPYRIGHT © GLICKBOEHM & ASSOCIATES, INC.
JOB NUMBER: 19136-00
DRAWN BY: CPM
CHECKED BY: WDB
APPROVED BY: WDB
DATE ISSUED FOR: CONSTRUCTION DOCUMENTS 11/04/22

FIRST FLOOR HVAC PLAN (PHASE 3)

MP300

DEMOLITION KEYNOTES

- 1 REMOVE OUTDOOR CONDENSING UNIT AND ASSOCIATED REFRIGERANT PIPE. PATCH REFRIGERANT WALL PENETRATIONS TO MATCH EXISTING.

RENOVATION KEYNOTES

- 1 PROVIDE HVAC CONDENSATE DRAIN PIT AT GRADE. SEE DETAIL.
- 2 PROVIDE CONCRETE HOUSEKEEPING PAD FOR NEW CONDENSING UNITS.

GENERAL NOTES

- 1. OUTDOOR HVAC EQUIPMENT SHALL BE MOUNTED ON A CONCRETE PAD. COORDINATE WITH THE GENERAL CONTRACTOR.

LEGEND

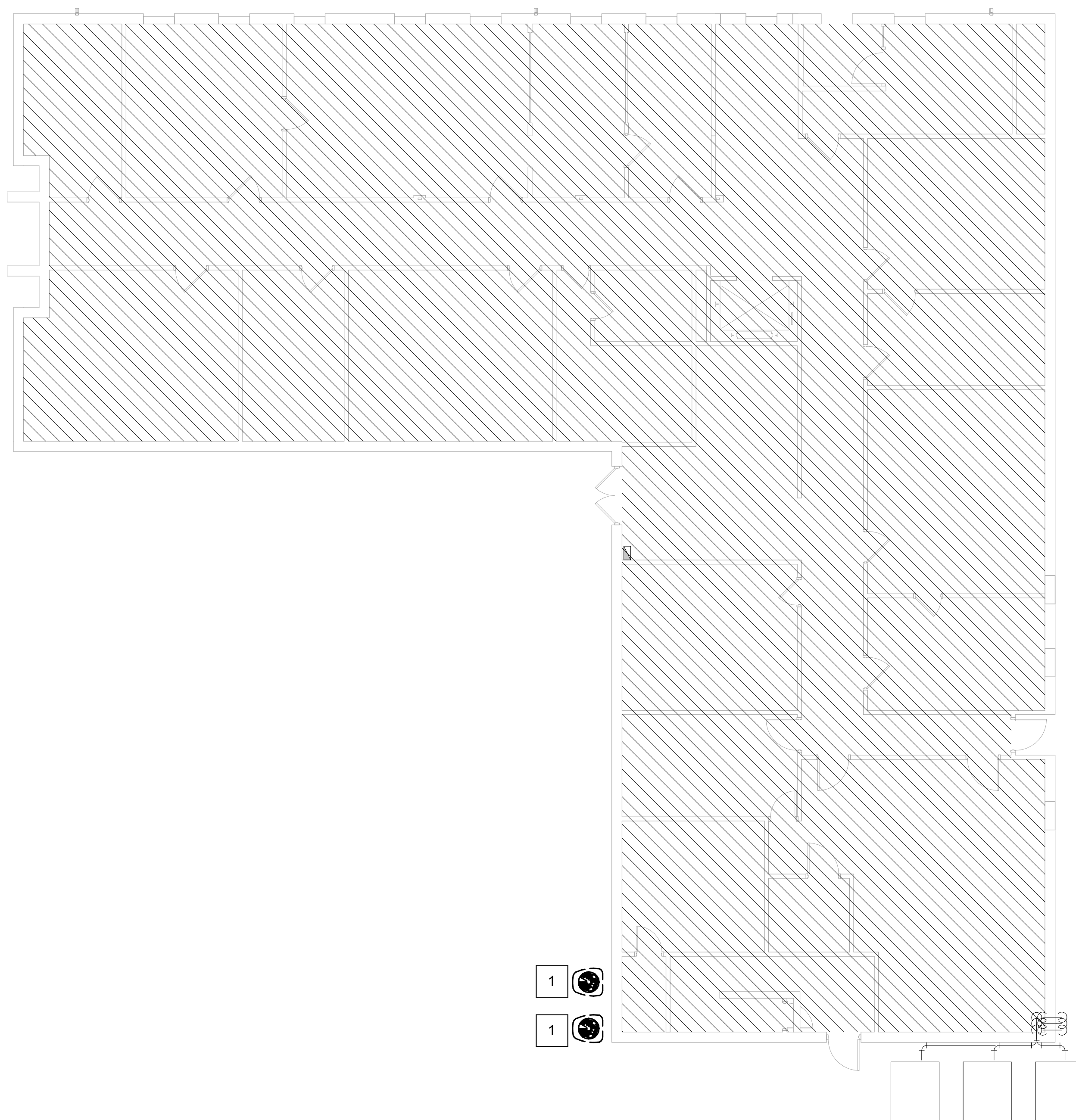
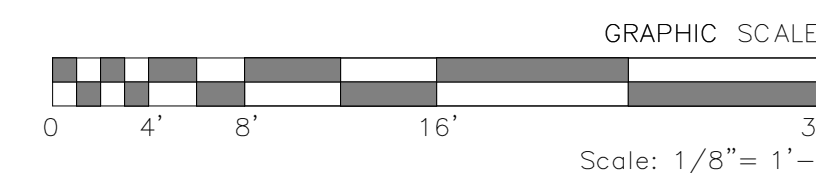
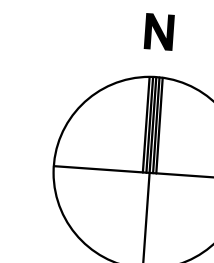

1 SECOND FLOOR HVAC DEMOLITION PLAN - PHASE 3
MP301 SCALE: 1/8" = 1'-0"

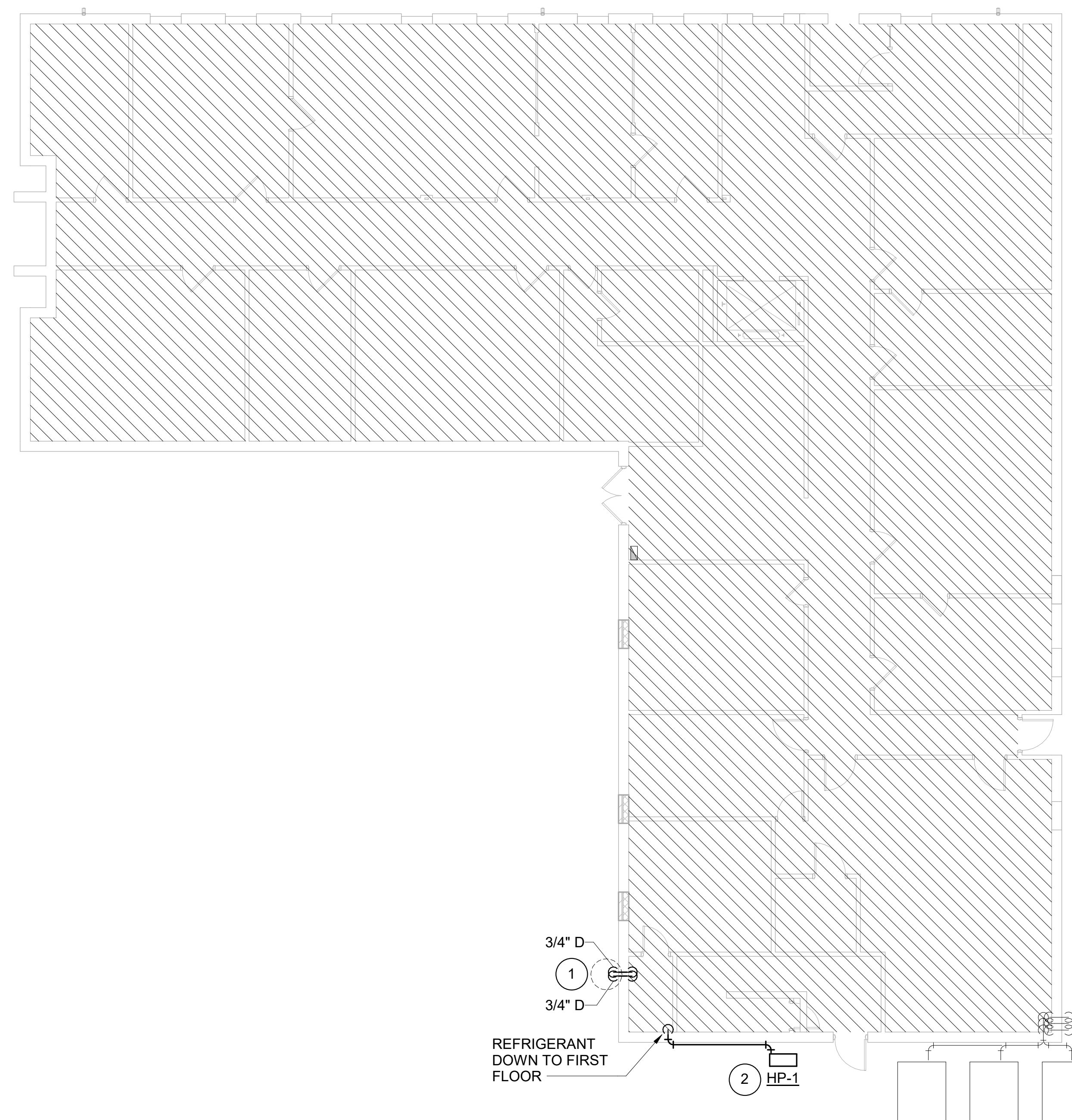

2 SECOND FLOOR HVAC RENOVATION PLAN - PHASE 3
MP301 SCALE: 1/8" = 1'-0"

| REV. | DATE | DESCRIPTION |
|------|------|-------------|
| | | |
| | | |
| | | |
| | | |

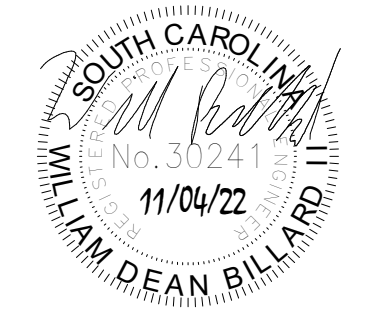
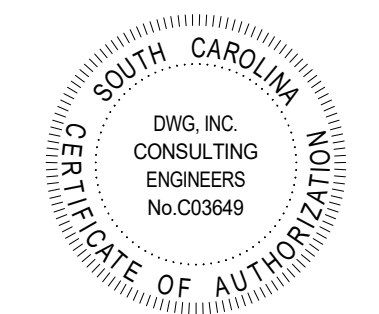

**HARRELSON BUILDING IT
DEPARTMENT
RENOVATION**
COLLETON COUNTY
31 KLEIN STREET,
WALTERBORO, SC 29488

COPYRIGHT © GLICKBOEHM & ASSOCIATES, INC.
JOB NUMBER: 19136-00
DRAWN BY: CPM
CHECKED BY: WDB
APPROVED BY: WDB
DATE ISSUED FOR: CONSTRUCTION DOCUMENTS 11/04/22

**SECOND
FLOOR HVAC
PLAN (PHASE 3)**

MP301

| LIGHTING SYMBOL LEGEND | | | |
|------------------------|---|----------------|--|
| SYMBOL | DESCRIPTION | SYMBOL | DESCRIPTION |
| | LIGHT FIXTURE (TYPICAL ALL DIMENSIONS) | ⋄ | LIGHT SWITCH, SINGLE POLE |
| | LIGHT FIXTURE (SHADING INDICATES EMERGENCY, TYPICAL ALL LIGHTING SYMBOLS) | ⋄ ^x | LIGHT SWITCH, "X" INDICATES SWITCH TYPE |
| | STRIP LIGHT FIXTURE | ⋄ ^a | LIGHT SWITCH, LOWERCASE LETTER INDICATES SWITCHLEG |
| | LIGHT FIXTURE (TYPICAL ALL DIMENSIONS) | Ⓞ | OCCUPANCY SENSOR (CEILING MOUNTED) |
| | EXIT SIGN, SINGLE SIDED (ARROWS INDICATE CHEVRON DIRECTION) | Ⓞ | OCCUPANCY SENSOR (WALL MOUNTED) |
| | EXIT SIGN, DOUBLE SIDED (ARROWS INDICATE CHEVRON DIRECTION) | Ⓞ | VACANCY SENSOR (CEILING MOUNTED) |

| POWER AND TELECOMMUNICATIONS SYMBOL LEGEND | | | |
|--|--|--------|--|
| SYMBOL | DESCRIPTION | SYMBOL | DESCRIPTION |
| ⊕ ^x | SIMPLEX RECEPTACLE "X" INDICATES RECEPTACLE TYPE | Ⓜ | CEILING MOUNTED COMMUNICATION OUTLET (TYPICAL ALL TYPES) |
| ⊕ | DUPLEX RECEPTACLE "X" INDICATES RECEPTACLE TYPE | Ⓜ | FLOOR MOUNTED COMMUNICATION OUTLET(TYPICAL ALL TYPES) |
| ⊕ ^x | GFCI DUPLEX RECEPTACLE "X" INDICATES RECEPTACLE TYPE | ∇ | COMMUNICATION OUTLET 2 DROPS |
| ⊕ ^x | QUADRUPLX RECEPTACLE "X" INDICATES RECEPTACLE TYPE | ∇ | COMMUNICATION OUTLET (ROUGH-IN ONLY) |
| ⊕ ^x | GFCI QUADRUPLX RECEPTACLE "X" INDICATES RECEPTACLE TYPE | TGB | TELECOMMUNICATIONS GROUNDING BUSBAR |
| | SPECIAL PURPOSE RECEPTACLE, SEE PLANS FOR NEMA CONFIGURATION AND BRANCH CIRCUITING | Ⓜ | THERMOSTAT (WALL MOUNTED, ROUGH-IN ONLY) |
| | FLOOR MOUNTED RECEPTACLE (TYPICAL ALL TYPES) | Ⓜ | HUMIDISTAT (WALL MOUNTED, ROUGH-IN ONLY) |
| ⊕ ^x | JUNCTION BOX (WALL MOUNTED) "X" INDICATES JUNCTION BOX TYPE | SPD | SURGE PROTECTION DEVICE |
| ⊕ ^x | JUNCTION BOX (CEILING MOUNTED) "X" INDICATES JUNCTION BOX TYPE | HH | HAND HOLE |
| ⋄ ^x | CONTROL SWITCH, "X" INDICATES SWITCH TYPE | Ⓜ | METER |
| | MOTOR CONNECTION (AS NOTED) | | PANELBOARD - BRANCH, SURFACE MOUNTED |
| | CABLE TRAY | | PANELBOARD - BRANCH, FLUSH MOUNTED |
| | PUSH BUTTON CONTROL | Ⓜ | TRANSFORMER |
| | DISCONNECT SWITCH (FUSIBLE OR NON-FUSIBLE) | | PANELBOARD - DISTRIBUTION, SURFACE MOUNTED |
| | ENCLOSED CIRCUIT BREAKER | | PANELBOARD - DISTRIBUTION, FLUSH MOUNTED |

| SYSTEMS SYMBOL LEGEND | | | |
|-----------------------|-----------------------------------|--------|---|
| SYMBOL | DESCRIPTION | SYMBOL | DESCRIPTION |
| Ⓞ | SMOKE DETECTOR (CEILING MOUNTED) | F | FIRE ALARM PULL STATION |
| Ⓞ | SMOKE DETECTOR (DUCT MOUNTED) | ∇ | FIRE ALARM STROBE NOTIFICATION APPLIANCE (WALL MOUNTED) |
| ⋄ ^x | CONTROL PANEL, "X" INDICATES TYPE | ∇ | FIRE ALARM HORN/STROBE NOTIFICATION APPLIANCE (WALL MOUNTED) |
| RFA | REMOTE FIRE ALARM ANNUNCIATOR | ∇ | FIRE ALARM STROBE NOTIFICATION APPLIANCE (CEILING MOUNTED) |
| AIM | ADDRESSABLE INPUT MODULE | ∇ | FIRE ALARM HORN/STROBE NOTIFICATION APPLIANCE (CEILING MOUNTED) |
| Ⓞ | SPEAKER (CEILING MOUNTED) | B | FIRE ALARM BELL NOTIFICATION APPLIANCE (WALL MOUNTED) |
| Ⓞ | SPEAKER (WALL MOUNTED) | CR | SECURITY CARD READER |
| ∇ | SECURITY CAMERA (CEILING MOUNTED) | KP | SECURITY KEYPAD |
| ∇ | SECURITY CAMERA (WALL MOUNTED) | D | DOOR POSITION SWITCH |
| E | ELECTRONIC DOOR STRIKE | M | MAGNETIC DOOR LOCK (ROUGH-IN ONLY) |

| ELECTRICAL CODES AND STANDARDS | |
|--------------------------------|--|
| CODE | DESCRIPTION |
| IBC (2018) | INTERNATIONAL BUILDING CODE |
| IECC (2009) | INTERNATIONAL ENERGY CONSERVATION CODE |
| IFC (2018) | INTERNATIONAL FIRE CODE |
| NFPA 70 (2017) | NATIONAL ELECTRICAL CODE |
| NFPA 72 (2016) | NATIONAL FIRE ALARM AND SIGNALING CODE |

| ELECTRICAL ABBREVIATIONS | |
|--------------------------|-------------------------------------|
| ABBR | DESCRIPTION |
| (E) | EXISTING |
| AFF | ABOVE FINISHED FLOOR |
| AFG | ABOVE FINISHED GRADE |
| AHU | AIR HANDLING UNIT |
| BOD | BOTTOM OF DEVICE |
| cd | CANDELA |
| CLG | CEILING |
| ECB | ENCLOSED CIRCUIT BREAKER |
| EF | EXHAUST FAN |
| FACP | FIRE ALARM CONTROL PANEL |
| FDS | FUSED DISCONNECT SWITCH |
| GBB | GROUND BUSBAR |
| GFCI | GROUND-FAULT CIRCUIT-INTERRUPTING |
| GFI | GROUND-FAULT INTERRUPTING |
| HP | HEAT PUMP |
| J-BOX | JUNCTION BOX |
| KW | KILOWATTS |
| MTGB | MAIN TELECOMM. GROUNDING BUSBAR |
| NEC | NATIONAL ELECTRICAL CODE |
| NFDS | NON-FUSED DISCONNECT SWITCH |
| RTU | ROOF TOP UNIT |
| SPD | SURGE PROTECTION DEVICE |
| TBB | TELECOMMUNICATIONS BACKBOARD |
| TGB | TELECOMMUNICATIONS GROUNDING BUSBAR |
| TP | TYPICAL |
| UNO | UNLESS NOTED OTHERWISE |
| UTP | UNSHIELDED TWISTED PAIR |
| W/ | WITH |
| WP | WEATHERPROOF |
| XFMR | TRANSFORMER |
| RECEPTACLE | DESCRIPTION |
| C | MOUNT ABOVE COUNTER |
| WP | WEATHERPROOF |
| CONTROL PANELS | DESCRIPTION |
| FACP | FIRE ALARM CONTROL PANEL |
| LIGHT SWITCH | DESCRIPTION |
| D | DIMMER |
| LV | LOW VOLTAGE |
| OS | OCCUPANCY SENSOR |

GENERAL ELECTRICAL NOTES

- BRANCH CIRCUIT WIRING FOR 20A CIRCUITS SHALL BE SIZED PER WIRE SIZING CHART. WHERE CONDUCTOR AND RACEWAY SIZE ARE SHOWN AT HOMERUN, SUCH SIZE SHALL BE USED FOR THE ENTIRE CIRCUIT. EXCEPTION: FINAL CONNECTION TO DEVICES IN OUTLET BOXES IS NOT REQUIRED TO BE LARGER THAN #12.
- PRIOR TO ROUGH-IN, COORDINATE THE LOCATION AND MOUNTING HEIGHT OF ALL WALL MOUNTED DEVICES WITH THE ARCHITECTURAL INTERIOR ELEVATIONS AND MILLWORK SHOP DRAWINGS. IN THE EVENT OF A CONFLICT, NOTIFY THE ARCHITECT. MINOR ADJUSTMENTS IN DEVICE LOCATION, SUCH AS 5'-0" IN ANY DIRECTION, SHALL BE DONE AT NO ADDITIONAL COST TO THE OWNER. UNDERCABINET LIGHT FIXTURES, RECEPTACLES AND OTHER DEVICES TO BE MOUNTED INSIDE CABINETS SHALL BE REVIEWED WITH THE ARCHITECT PRIOR TO ROUGH IN TO CONFIRM THE EXACT LOCATION OF FIXTURES AND DEVICES. OUTLET BOXES FOR SWITCHES, RECEPTACLES, ETC. MOUNTED ON OPPOSITE SIDES OF PARTITIONS SHALL NOT BE MOUNTED IN THE SAME WALL CAVITY. SEPARATE WALL PENETRATIONS BY MOUNTING ON OPPOSITE SIDES OF WALL STUDS OR OTHER VERTICAL STRUCTURAL MEMBERS IN THE WALL.
- RACEWAYS SHALL BE INSTALLED CONCEALED IN NEW WALL CONSTRUCTION, ABOVE CEILINGS, BELOW FLOOR AND IN OTHER CAVITIES TO THE GREATEST EXTENT POSSIBLE. EXPOSED RACEWAYS MAY BE USED IN UNFINISHED SPACES, WHERE EXPLICITLY NOTED ON PLANS AND WHERE APPROVED BY THE ARCHITECT AND ENGINEER. LAY OUT EXPOSED RACEWAYS TO MINIMIZE THE NUMBER OF VERTICAL RUNS.
- FEEDER CONDUITS, BRANCH CIRCUITS AND CABLE TRAY ROUTING SHALL COMPLY WITH DETAILS ON DRAWINGS AND SHALL BE COORDINATED WITH THE WORK OF OTHER TRADES BEFORE AND DURING CONSTRUCTION. FEEDER CONDUITS AND BRANCH CIRCUITS SHALL BE ROUTED OVERHEAD UNLESS PRIOR APPROVAL HAS BEEN GRANTED BY THE ARCHITECT AND ENGINEER.
- A FIRESTOP SYSTEM SHALL BE USED TO SEAL ALL PENETRATIONS OF ELECTRICAL CONDUITS AND CABLES THROUGH FIRE-RATED PARTITIONS. THE FIRESTOP SYSTEM SHALL CONSIST OF A FIRE-RATED CAULK TYPE SUBSTANCE AND HIGH TEMPERATURE FIBER INSULATION BY STI OR APPROVED EQUAL. ONLY METAL CONDUIT SHALL BE USED TO PENETRATE FIRE-RATED PARTITIONS. SEE ARCHITECTURAL DRAWINGS FOR ALL LOCATIONS OF FIRE-RATED WALLS.
- THE USE OF MC CABLE IS ALLOWED ABOVE ACCESSIBLE CEILINGS AND IN STUD CONSTRUCTION ONLY. HOMERUNS TO PANEL SHALL BE WIRE IN RACEWAY ONLY. MC CABLE IS NOT ACCEPTABLE FOR HOMERUNS. MC CABLE IS ONLY ACCEPTABLE FOR 20A BRANCH CIRCUITS. THE USE OF MC CABLE IS NOT ALLOWED IN IT ROOM.
- PROVIDE A LISTED EXPANSION/DEFLECTION FITTING FOR ALL CONDUIT CROSSING EXPANSION JOINTS PER NEC 300.4.H. SEE ARCHITECTURAL DRAWINGS FOR LOCATIONS OF EXPANSION JOINTS.
- WHEREVER THE WORD "PROVIDE" IS USED ON THE ELECTRICAL DRAWINGS, IT SHALL BE INFERRED TO MEAN "FURNISH AND INSTALL", UNLESS NOTED OTHERWISE.
- THE ARRANGEMENT, GROUPING, AND ROUTING OF BRANCH CIRCUITS SHALL BE PROVIDED AT THE CONTRACTOR'S DISCRETION IN ACCORDANCE WITH GENERALLY ACCEPTED PRACTICE FOR ELECTRICAL WORK, THE NATIONAL ELECTRICAL CODE REQUIREMENTS, LOCAL ORDINANCES, AND THE FOLLOWING: 1 - A COMMON NEUTRAL MAY BE INSTALLED IN A HOMERUN FOR 2 OR 3 BRANCH CIRCUITS ONLY IF A MEANS TO SIMULTANEOUSLY DISCONNECT ALL UNGROUNDED CONDUCTORS AT THE POINT OF ORIGIN IS PROVIDED PER NEC 210.4.B. 2 - MULTIPLE SINGLE-POLE BRANCH CIRCUITS (UP TO 3 HOTS, 3 NEUTRALS AND 1 GROUND) RATED FOR 30A OR LESS MAY BE PULLED INTO A SINGLE RACEWAY. THE CONTRACTOR SHALL BE RESPONSIBLE FOR SIZING THE RACEWAYS AND DE-RATING CONDUCTORS PER NEC 310.15. 3 - A GROUND CONDUCTOR SHALL BE PROVIDED IN ALL RACEWAYS UNLESS NOTED OTHERWISE.
- REFER TO THE ARCHITECTURAL DRAWINGS FOR PROJECT PHASING.

GENERAL POWER NOTES

- PROVIDE NEMA CONFIGURATION RECEPTACLES TO MATCH PLUGS ON EQUIPMENT FURNISHED.

GENERAL LIGHTING NOTES

- SEE ARCHITECTURAL REFLECTED CEILING PLAN FOR THE EXACT LOCATION OF ALL CEILING MOUNTED LIGHTING FIXTURES. REFER TO ARCHITECTURAL DRAWINGS FOR MOUNTING DETAILS OF LIGHT FIXTURE TO ACOUSTICAL CEILING SYSTEM AND STRUCTURE.
- EXACT LOCATIONS OF LIGHTING FIXTURES IN MECHANICAL SPACES SHALL BE DETERMINED IN THE FIELD. DO NOT SUPPORT FIXTURES FROM DUCT OR PIPING. PROVIDE CHAIN OR TRAPEZE-TYPE HANGERS WHERE FIXTURES CANNOT BE MOUNTED DIRECTLY TO CEILING.
- LIGHTING FIXTURE CATALOG NUMBERS ARE INDICATIVE OF THE STYLE OF FIXTURE REQUIRED. CONTRACTOR SHALL PROVIDE FIXTURES WITH THE PROPER TRIM, VOLTAGE AND OPTIONS NECESSARY FOR INSTALLATION.
- DOUBLE-FACED EXIT FIXTURES SHALL BE OF THE SAME MANUFACTURER AND SERIES AS THE SINGLE-FACED EXIT FIXTURES.
- REGARDLESS OF CATALOG NUMBER INDICATED IN SCHEDULE, PROVIDE BATTERY BACK-UP FOR ALL FIXTURES INDICATED ON THE DRAWINGS TO BE EMERGENCY TYPE.

| WIRE SIZING CHART 20 AMP BRANCH CIRCUITS | |
|---|-------------------|
| DISTANCE, 120V | MINIMUM WIRE SIZE |
| 0 - 90 FEET | #12 AWG |
| 90 - 230 FEET | #10 AWG |
| 230 - 446 FEET | #8 AWG |

GENERAL EXISTING CONDITION NOTES

- AREAS OF WORK EXIST FOR THIS PROJECT WHICH WERE NOT ACCESSIBLE OR HAD LIMITED ACCESS DURING DESIGN. AS SUCH, CONTRACTOR SHALL VERIFY ALL UTILITIES IN AREA OF WORK BEFORE DEMOLITION OF ANY SERVICE. ANY ELECTRICAL COMPONENTS NOT SHOWN SHALL BE IDENTIFIED AND THE ARCHITECT AND ENGINEER SHALL BE NOTIFIED AS SOON AS POSSIBLE. NO ELECTRICAL REWORK SHALL BE COMMENCED WITHOUT COORDINATION OF BOTH ARCHITECT AND ENGINEER. WHERE INFORMATION SHOWN ON THESE DRAWINGS CONFLICTS WITH VERIFIED FIELD CONDITIONS, IT SHALL BE BROUGHT TO THE ATTENTION OF THE ARCHITECT AND ENGINEER.
- IN AREAS WHERE THE EXISTING CEILINGS ARE NOT SLATED TO BE REPLACED, THE CONTRACTOR SHALL WORK THROUGH THE EXISTING CEILINGS (SEE ARCHITECTURAL REFLECTED CEILING PLAN FOR AREA OF WORK). THE CONTRACTOR SHALL BE RESPONSIBLE FOR REPLACING ANY DAMAGED TILE OR GRID THAT IS A RESULT OF THEIR WORK. ALL WORK PERFORMED ABOVE EXISTING CEILINGS SHALL BE PERFORMED AFTER HOURS AND SCHEDULED WITH THE OWNER IN ADVANCE.
- THE CONTRACTOR SHALL BE RESPONSIBLE FOR INSTALLING A FIRESTOP SYSTEM IN ALL PENETRATIONS OF FIRE-RATED FLOORS AND WALLS CREATED BY THE REMOVAL OF EXISTING ELECTRICAL CONDUIT OR CABLES, AS WELL AS THOSE CREATED BY NEWLY INSTALLED CONDUITS AND SLEEVES.
- SUPPORT ALL EXISTING CONDUITS AND JUNCTION BOXES ABOVE THE CEILING IN THE CONSTRUCTION AREA PER NEC.
- REMOVE ALL ABANDONED CONDUIT, WIRE AND CABLES ABOVE THE CEILING IN THE CONSTRUCTION AREA.
- PROVIDE JUNCTION BOX COVERS ON ALL EXISTING JUNCTION BOXES ABOVE THE CEILING IN THE CONSTRUCTION AREA.
- SUPPORT ALL EXISTING CABLES TO REMAIN ABOVE THE CEILING IN THE CONSTRUCTION AREA.

GENERAL LOW VOLTAGE NOTES

- THE WALLS OF THE ENTIRE IT ROOM SHALL BE COVERED BY 3/4"D PLYWOOD WITH THE BOTTOM AT 6" ABOVE FINISHED FLOOR. EXTEND A #6 BARE COPPER GROUNDING CONDUCTOR FROM THE ELECTRICAL SERVICE GROUND TO THE BACKBOARD AND LEAVE WITH SUFFICIENT SLACK TO REACH ANY PLACE THEREON. COAT BACKBOARD WITH A MINIMUM OF TWO COATS OF FIRE RETARDANT PAINT.
- EXTEND A 1" CONDUIT WITH PULL WIRE FROM EACH COMMUNICATIONS OUTLET TO ABOVE THE LAY-IN CEILING. TURN CONDUIT 12" INTO CEILING CAVITY A MINIMUM OF 6" ABOVE THE CEILING AND TERMINATE WITH AN INSULATED THROAT BUSHING.
- EXTEND A 1/2" CONDUIT WITH PULL WIRE FROM EACH ACCESS CONTROL ROUGH IN TO ABOVE THE LAY-IN CEILING. TURN CONDUIT 12" INTO CEILING CAVITY A MINIMUM OF 6" ABOVE THE CEILING AND TERMINATE WITH AN INSULATED THROAT BUSHING.
- THE MAIN TELECOMMUNICATIONS GROUNDING BUSBAR (MTGB) SHALL BE A PRE-DRILLED COPPER BUSBAR WITH STANDARD NEMA BOLT HOLE SIZING THAT IS NO SMALLER THAN 6MM THICK BY 100MM WIDE BY 1 FOOT LONG. THE MTGB SHALL BE BONDED TO THE BUILDING SERVICE GROUND AND ALL TELECOMMUNICATIONS METALLIC RACEWAYS LOCATED IN THE SAME ROOM. MTGB CONNECTIONS SHALL BE LISTED TWO HOLE COMPRESSION TYPE.
- A #4 INSULATED COPPER CONDUCTOR RUNNING FROM THE MTGB TO ALL OTHER TELECOMMUNICATION GROUNDING BUSBARS SHALL CONSTITUTE THE TELECOMMUNICATIONS BONDING BACKBONE (TBB).
- EACH TELECOMMUNICATION GROUNDING BUSBAR (TGB) SHALL BE A PRE-DRILLED COPPER BUSBAR WITH STANDARD NEMA BOLT HOLE SIZING THAT IS NO SMALLER THAN 6MM THICK BY 50MM WIDE BY 1 FOOT LONG. CONNECTIONS SHALL BE LISTED TWO HOLE COMPRESSION TYPE.
- PROVIDE SLEEVES SIZED FOR 40% EXPANSION THROUGH CORRIDOR WALLS.
- ALL COMMUNICATION DROPS SHALL BE UNSPLICED HOME RUNS FROM DEVICE PLATE TO THE COMMUNICATION RACK LOCATION. PROVIDE 10 FEET OF COILED CABLE AT RACK LOCATION FOR OWNER'S USE.
- SUPPORT CABLES WITH J-HOOKS. J-HOOKS SHALL BE PROVIDED AT INTERVALS LESS THAN 5 FEET. PROVIDE METAL SLEEVES FOR ALL WALL PENETRATIONS. DO NOT SUPPORT CABLES FROM STRUCTURE. SEAL ALL FIRE RATED WALL PENETRATIONS. REFER TO ARCHITECTURAL SPECIFICATIONS AND DRAWINGS FOR LOCATIONS AND REQUIREMENTS.
- ALL COMMUNICATION CABLING SHALL COMPLY WITH THE NATIONAL ELECTRIC CODE AND EIA/TIA STANDARDS.
- CABLE SHALL BE CONCEALED IN ALL FINISHED AREAS AND ROUTED PARALLEL OR PERPENDICULAR TO THE BUILDING STRUCTURE.
- CONTRACTOR SHALL HIRE PALMETTO RURAL TELEPHONE COOPERATIVE (PRTC) AS THE NETWORK PROVIDER. NO OTHER SUPPLIER WILL BE USED.
- CABLING IS ONLY TO BE PROVIDED FOR SCOPE OF INSTALLATION WITHIN THIS PROJECT. CABLING TO EXISTING FEEDERS AND DATA JACKS OUTSIDE OF THE SCOPE OF THIS PROJECT WILL BE COMPLETED BY OWNER.

GENERAL DEMOLITION NOTES

- ALL ELECTRICAL EQUIPMENT TO BE REMOVED SHALL REMAIN THE PROPERTY OF THE OWNER. THE CONTRACTOR SHALL NOT DISPOSE OF ANY MATERIALS UNTIL RELEASED BY THE OWNER'S PROJECT MANAGER. MATERIALS THAT THE OWNER'S PROJECT MANAGER CHOOSES TO RETAIN SHALL BE DELIVERED BY THE CONTRACTOR TO A LOCATION DESIGNATED BY THE PROJECT MANAGER. ALL OTHER MATERIALS SHALL BE PROPERLY DISPOSED OF BY THE CONTRACTOR.

| LINE LEGEND | |
|-------------|--------------------|
| SYMBOL | DESCRIPTION |
| | EXISTING TO REMAIN |
| | NEW CONSTRUCTION |
| | DEMOLISH |

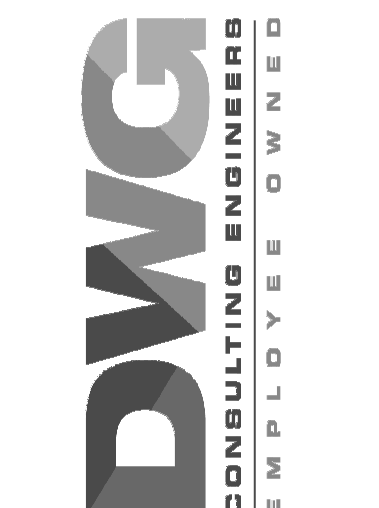

| REV. | DATE | DESCRIPTION |
|------|------|-------------|
| | | |
| | | |
| | | |
| | | |
| | | |
| | | |
| | | |
| | | |
| | | |
| | | |



**HARRELSON BUILDING IT
DEPARTMENT
RENOVATION**
COLLETON COUNTY
31 KLEIN STREET,
WALTERBORO, SC 29488

COPYRIGHT © GLICKBOEHM & ASSOCIATES, INC.
JOB NUMBER: 19136-00
DRAWN BY: MHS
CHECKED BY: BSB
APPROVED BY: MHS
DATE ISSUED FOR: CONSTRUCTION DOCUMENTS 11/04/22

ELECTRICAL NOTES

LIGHT FIXTURE SCHEDULE

| FIXTURE SPECIFICATIONS | | | | LAMPING | | | ELECTRICAL | | MOUNTING REMARKS | NOTES |
|------------------------|---|--------------|----------------------------------|-----------|--------------|-------------|------------|-------|------------------------|-------|
| TYPE | FIXTURE DESCRIPTION | MANUFACTURER | CAT. # | LAMP TYPE | TOTAL LUMENS | COLOR TEMP. | LOAD (VA) | VOLTS | | |
| A2E | 2'X2' TROFFER (INTEGRAL EMERGENCY BATTERY) | WILLIAMS | AT1-2-2-L30/835-D-EM/10W-DIM-UNV | LED | 3028 | 3500 K | 30 | 120 V | RECESSED | |
| A4 | 2'X4' TROFFER | WILLIAMS | AT1-2-4-L40/835-D-DIM-UNV | LED | 4035 | 3500 K | 34 | 120 V | RECESSED | |
| A4E | 2'X4' TROFFER (INTEGRAL EMERGENCY BATTERY) | WILLIAMS | AT1-2-4-L40/835-D-EM/10W-DIM-UNV | LED | 4035 | 3500 K | 34 | 120 V | RECESSED | |
| L1 | 4' ROUND LENS NARROW STRIP | WILLIAMS | 75R-4-L50/835-DIM-UNV | LED | 5126 | 3500 K | 33 | 120 V | SUSPENDED AT 8'-0" AFF | |
| L1E | 4' ROUND LENS NARROW STRIP (INTEGRAL EMERGENCY BATTERY) | WILLIAMS | 75R-4-L50/835-EM/10WLP-DIM-UNV | LED | 5126 | 3500 K | 33 | 120 V | SUSPENDED AT 8'-0" AFF | |
| L2 | 4' ROUND LENS NARROW STRIP | WILLIAMS | 75R-4-L50/835-DIM-UNV | LED | 5126 | 3500 K | 33 | 120 V | 8' AFF | 1 |
| X2 | WHITE THERMOPLASTIC EXIT SIGN | WILLIAMS | EXIT-R-EM-WHT-D | LED | | | 4 | 120 V | CEILING | |

GENERAL LIGHT FIXTURE SCHEDULE NOTES:

- CONFIRM 8' HEIGHT WORKS WITH CONTAINMENT AREA CEILING HEIGHT. IF THERE IS CONFLICT, LOCATE LIGHT FIXTURE 1' BELOW THE CONTAINMENT AREA CEILING.
- ACCEPTABLE ALTERNATE MANUFACTURERS ARE COLUMBIA LIGHTING, LITHONIA, HALO, AND SIGNIFY.

LIGHT FIXTURE PLAN KEY

SHADING INDICATES EMERGENCY FIXTURE SUPPLIED WITH EMERGENCY BATTERY BACKUP.

- A1 d A1 = UPPERCASE LETTER / NUMBER INDICATE FIXTURE TYPE
- d = LOWERCASE LETTER INDICATES SWITCH IDENTIFICATION
- NL = INDICATES NON-SWITCHED "NIGHT LIGHT"
- A:2 A:2 = DESIGNATES PANEL NAME: CIRCUIT NUMBER

ALL EMERGENCY FIXTURES INDICATED ON PLAN CONTAIN EMERGENCY BATTERY BACKUP. ALL EMERGENCY BACKUP FIXTURES REQUIRE AN EXTRA CONSTANT POWER CONDUCTOR TO BE CONNECTED TO THE EMERGENCY BACKUP FOR CHARGING. THIS CONDUCTOR MUST NOT BE CONTROLLED BY ANY LIGHTING SYSTEM OR HAVE POWER INTERRUPTED AT ANY TIME. "NL" FIXTURES SHALL HAVE ABSOLUTELY NO LIGHTING CONTROL AND SHALL BE OPERATIONAL AT ALL TIMES.

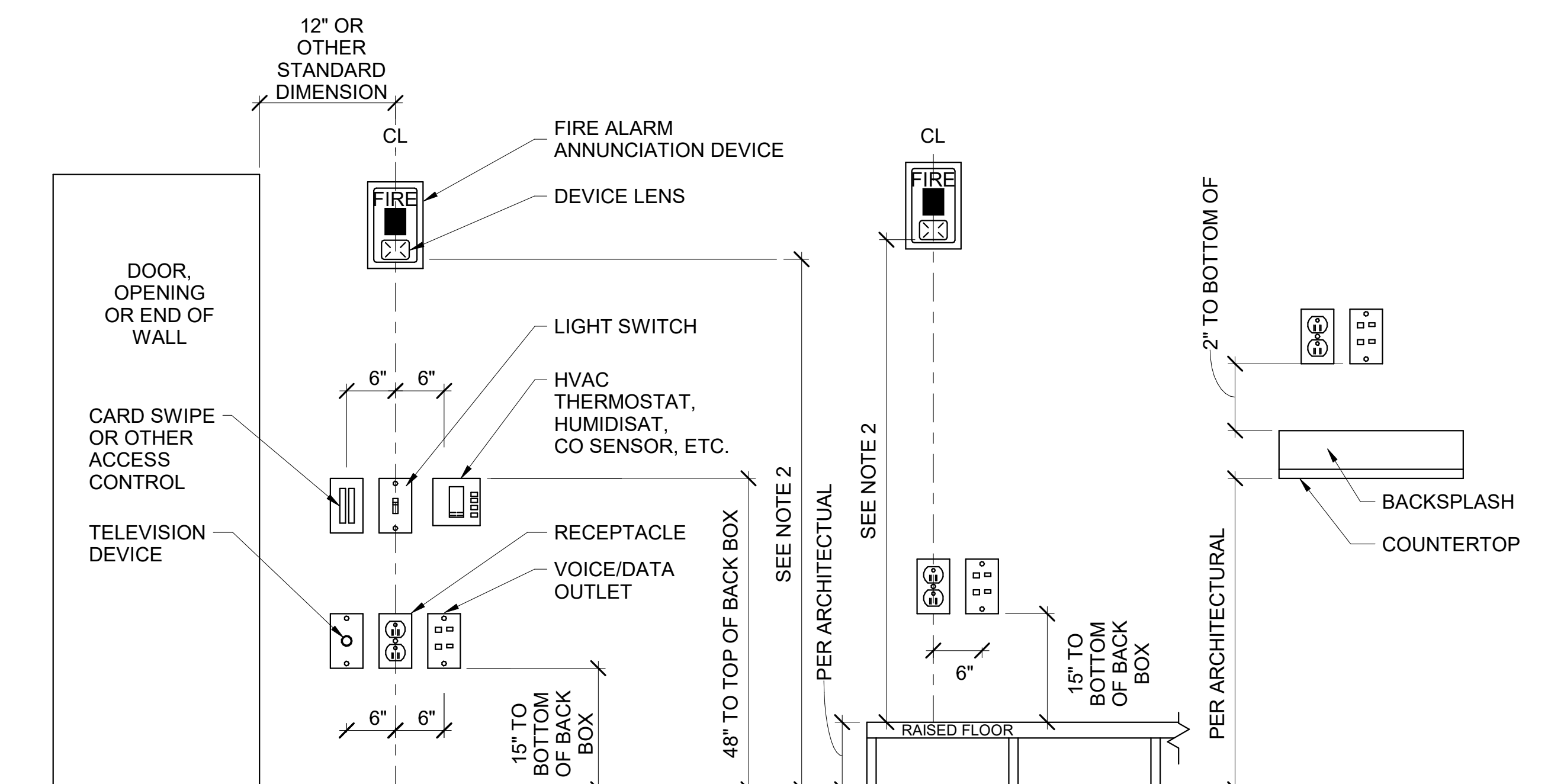

NOTE 1: DEVICES SHOWN WITHIN 48" OF EACH OTHER ON ALL ELECTRICAL PLANS SHALL BE ALIGNED PER THIS DETAIL. IF DEVICES ARE SHOWN IN MIDDLE OF WALL, THEN CENTER DEVICES ON WALL.

NOTE 2: MOUNT 80" ABOVE FINISHED FLOOR WHERE POSSIBLE. WHERE CEILING HEIGHTS DO NOT ALLOW THIS HEIGHT, MOUNT 6" BELOW CEILING. WHERE OBSTRUCTIONS DO NOT ALLOW THIS HEIGHT, MOUNT 80" TO 96" ABOVE FINISHED FLOOR. ALL MOUNTING HEIGHTS FOR NOTIFICATION DEVICES SHALL BE MEASURED TO THE BOTTOM OF THE LENS.

1 DEVICE ALIGNMENT DETAIL
E002 NOT TO SCALE

EQUIPMENT CONNECTION SCHEDULE

| UNIT I.D. | VOLTS | # OF POLES | LOAD (VA) | BRANCH CIRCUIT WIRING | DISCONNECT AMPS/POLES/NEMA RATING | NOTES |
|------------------------------------|-------|------------|-----------|------------------------|-----------------------------------|-------|
| CONDENSING UNIT | | | | | | |
| CU-1 | 208 V | 3 | 1009 | (3) #12, #12G IN 3/4"C | PROVIDED WITH UNIT | |
| CU-2 | 208 V | 3 | 1009 | (3) #12, #12G IN 3/4"C | PROVIDED WITH UNIT | |
| CU-3 | 208 V | 3 | 1009 | (3) #12, #12G IN 3/4"C | PROVIDED WITH UNIT | |
| CRAC | | | | | | |
| CRAC-1 | 208 V | 3 | 22336 | (3) #2, #8G IN 1 1/4"C | PROVIDED WITH UNIT | |
| CRAC-2 | 208 V | 3 | 22336 | (3) #2, #8G IN 1 1/4"C | PROVIDED WITH UNIT | |
| CRAC-3 | 208 V | 3 | 22336 | (3) #2, #8G IN 1 1/4"C | PROVIDED WITH UNIT | |
| DUCTLESS MINI-SPLIT SYSTEMS | | | | | | |
| MS-1a | 208 V | 2 | 208 | (2) #12, #12G IN 3/4"C | MOTOR RATED SWITCH | 1 |
| MS-1b | 208 V | 2 | 208 | (2) #12, #12G IN 3/4"C | MOTOR RATED SWITCH | 1 |
| HEAT PUMP | | | | | | |
| HP-1 | 208 V | 2 | 4596 | (2) #10, #10G IN 3/4"C | 30A/2P/3R NFDS | |

EQUIPMENT CONNECTION SCHEDULE NOTES:

- INDOOR UNIT SHALL BE POWERED FROM OUTDOOR UNIT HP-1.

ELECTRICAL SYSTEMS SEISMIC REQUIREMENTS PER IBC-2018/ASCE 7-16

- PER THE 2018 INTERNATIONAL BUILDING CODE, MECHANICAL, PLUMBING AND ELECTRICAL EQUIPMENT AND COMPONENTS, INCLUDING THEIR SUPPORTS AND ATTACHMENTS, SHALL BE DESIGNED FOR SEISMIC FORCES IN ACCORDANCE WITH CHAPTER 13 OF ASCE 7-16.
- EXTERIOR EQUIPMENT (INCLUDING ROOF CURBS, RAILS, SUPPORTS) EXPOSED TO WIND SHALL BE DESIGNED AND INSTALLED TO RESIST THE WIND PRESSURES DETERMINED IN ACCORDANCE WITH CHAPTER 26 TO 29 OF ASCE 7-16.
- WHERE DESIGN FOR SEISMIC AND WIND LOADS IS REQUIRED, THE MORE DEMANDING FORCE MUST BE USED.
- REFERENCE THE STRUCTURAL DRAWINGS FOR SITE SPECIFIC INFORMATION ON SEISMIC DESIGN CATEGORY, WIND SPEEDS, ETC.
- USE THE TABLE BELOW TO DETERMINE SEISMIC RESTRAINT REQUIREMENTS FOR EACH COMPONENT.
- FOR ALL COMPONENTS REQUIRING SEISMIC RESTRAINT, THE COMPONENT SUPPORTS AND ATTACHMENTS SHALL BE DESIGNED BY A REGISTERED DESIGN PROFESSIONAL REGISTERED IN THE STATE THE JOB IS LOCATED. SUBMITTALS MUST INCLUDE STAMPED AND SIGNED DRAWINGS AND CALCULATIONS.
- WHERE SEISMIC RESTRAINT IS REQUIRED, HOUSEKEEPING PADS NEEDED FOR THE INSTALLATION OF EQUIPMENT UNDER THIS CONTRACT MUST BE DESIGNED BY THE SEISMIC ENGINEER. DO NOT POUR ANY HOUSEKEEPING PADS PRIOR TO THE RECEIPT OF THE APPROVED SEISMIC SUBMITTAL.
- SEISMIC RESTRAINTS FOR DUCTWORK, PIPING, CONDUIT, CABLE TRAYS AND BUS DUCT MUST BE SHOWN ON LAYOUT DRAWINGS SHOWING SPECIFIC RESTRAINT LOCATIONS ALONG WITH ACCOMPANYING DETAILS AND CALCULATIONS.

ELECTRICAL COMPONENT IMPORTANCE FACTOR (Ip) DESIGNATION

| Ip = 1.0 | Ip = 1.5 |
|---|---|
| • ALL ASSOCIATED ELECTRICAL WORK UNLESS NOTED OTHERWISE | • EMERGENCY LIGHTS • EXIT LIGHTS • FIRE ALARM |

SEISMIC DESIGN CATEGORIES D,E,F

| COMPONENT IDENTIFICATION | COMPONENT IMPORTANCE FACTOR (Ip) | | | |
|--------------------------------------|--|-------|--|-------|
| | 1.0 | | 1.5 | |
| | SEISMIC RESTRAINT REQUIREMENT | NOTES | SEISMIC RESTRAINT REQUIREMENT | NOTES |
| ROOF MOUNTED | RESTRAIN ALL | 1 | RESTRAIN ALL | - |
| FLOOR MOUNTED | RESTRAIN ALL | 1,2 | RESTRAIN ALL | - |
| WALL MOUNTED | RESTRAIN ALL | 1,2 | RESTRAIN ALL | - |
| COMPONENT SUPPORTS | RESTRAIN ALL | 1 | RESTRAIN ALL | - |
| SUSPENDED EQUIPMENT | RESTRAIN ALL | 1 | RESTRAIN ALL | - |
| SINGLE CONDUIT | RESTRAIN IF ≥ 2.5" | 3 | RESTRAIN IF ≥ 2.5" | 3 |
| CABLE TRAY/BUS DUCT TRAPEZED CONDUIT | DO NOT DELETE ON TRAPEZE > 2.5". RESTRAIN IF TOTAL WEIGHT OF SUSPENDED COMPONENT > 10 LBS/FT | 3 | RESTRAIN IF ANY CONDUIT ON TRAPEZE > 2.5". RESTRAIN IF TOTAL WEIGHT OF SUSPENDED COMPONENT > 10 LBS/FT | 3 |
| COMPONENT CERTIFICATION | NOT REQUIRED | - | REQUIRED | 5 |
| PENDANT, LAY-IN AND CAN LIGHTS | REQUIRED | 4 | REQUIRED | 4 |

- NOTES:**
- EQUIPMENT 20 LBS. OR LESS IS EXEMPT IF THE COMPONENT IS POSITIVELY ATTACHED TO THE STRUCTURE AND FLEXIBLE CONNECTIONS ARE PROVIDED BETWEEN THE COMPONENT AND ASSOCIATED DUCTWORK, PIPING AND CONDUIT.
 - RESTRAINTS ARE NOT REQUIRED IF THE COMPONENT WEIGHS 400 LBS. OR LESS, IS MOUNTED WITH THE CENTER MASS AT 4' OR LESS ABOVE A FLOOR, IS POSITIVELY ATTACHED TO THE STRUCTURE, AND HAS FLEXIBLE CONNECTIONS BETWEEN THE COMPONENT AND ASSOCIATED DUCTWORK, PIPING AND CONDUIT.
 - RESTRAINT IS NOT REQUIRED IF THE CONDUIT IS SUPPORTED BY HANGERS AND EACH HANGER IN THE RUN IS 12" IN. OR LESS IN LENGTH FROM THE TOP OF THE PIPE TO THE SUPPORTING STRUCTURE. WHERE PIPES ARE SUPPORTED ON A TRAPEZE, THE TRAPEZE SHALL BE SUPPORTED BY HANGERS HAVING A LENGTH OF 12" IN. OR LESS. WHERE ROD HANGERS ARE USED, THEY SHALL BE EQUIPPED WITH SWIVELS, EYE NUTS OR OTHER DEVICES TO PREVENT BENDING IN THE ROD.
 - THE RESTRAINT OF PENDANT, LAY-IN AND CAN LIGHTS IS ADDRESSED IN ASTM C636 AND E580.
 - COMPONENT CERTIFICATION MUST BE SUPPLIED BY THE EQUIPMENT MANUFACTURER AT TIME OF SUBMITTAL FOR REVIEW BY ENGINEER OF RECORD.

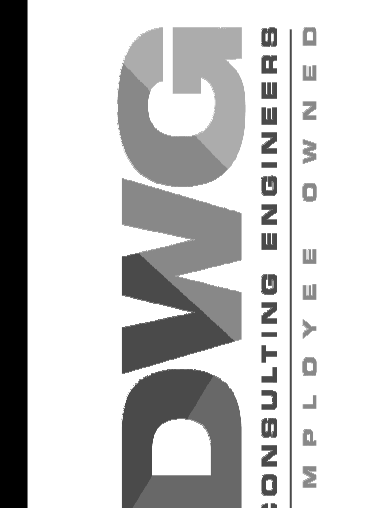

| REV. | DATE | DESCRIPTION |
|------|------|-------------|
| | | |
| | | |
| | | |
| | | |

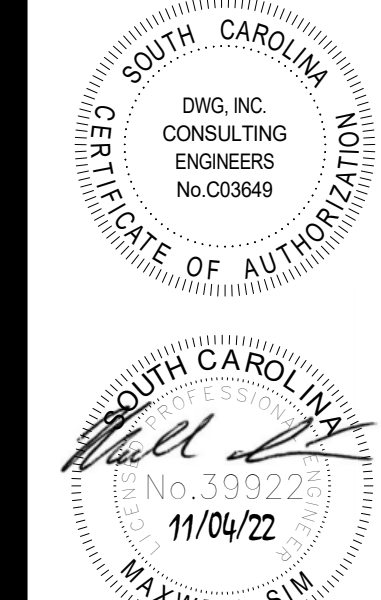

HARRELSON BUILDING IT DEPARTMENT RENOVATION
COLLETON COUNTY
31 KLEIN STREET,
WALTERBORO, SC 29488

COPYRIGHT © GLICKBOEHM & ASSOCIATES, INC.
JOB NUMBER: 19138-00
DRAWN BY: MHS
CHECKED BY: BSB
APPROVED BY: MHS
DATE ISSUED FOR: CONSTRUCTION DOCUMENTS
11/04/22

ELECTRICAL SCHEDULES AND DETAILS

E002

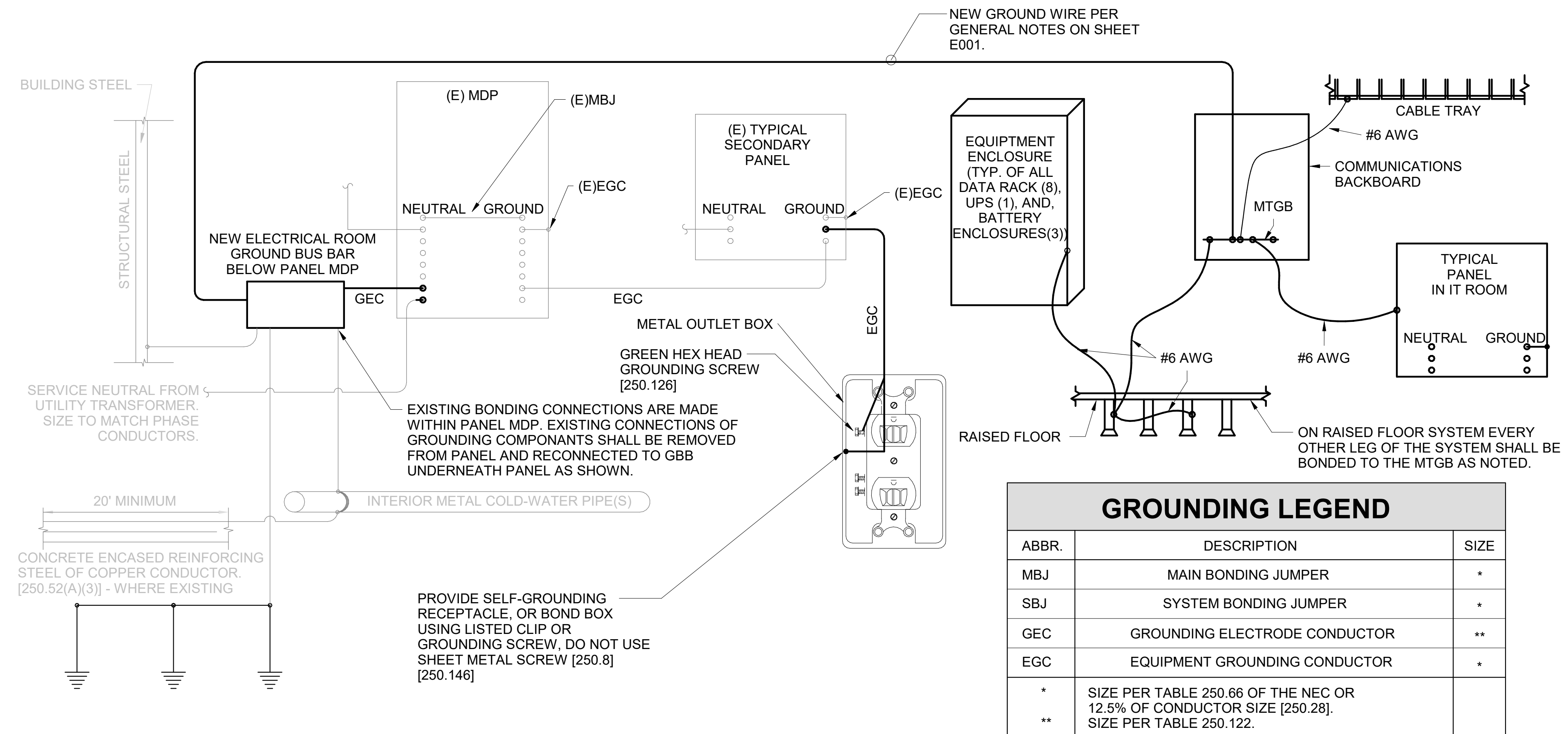

GROUNDING NOTES:

- NUMBERS IN BRACKETS REFER TO SPECIFIC SECTIONS OF THE NATIONAL ELECTRICAL CODE.
- ALL UNDERGROUND OR OTHERWISE INACCESSIBLE GROUND CONNECTIONS AND SPLICES SHALL BE EXOTHERMICALLY WELDED [250.68].
- GROUND ELECTRODE FOR SEPARATELY DERIVED SYSTEMS SHALL BE THE NEAREST METAL WATER PIPE OR STRUCTURAL METAL. IF EITHER IS NOT AVAILABLE, PROVIDE GROUNDING CONDUCTOR BACK TO MAIN GROUND BUS AT SERVICE ENTRANCE.
- PROVIDE A GROUND WIRE IN ALL CONDUITS.
- EARTH SHALL NOT BE USED AS THE SOLE GROUND RETURN PATH FOR ANY EQUIPMENT POWERED UNDER THIS PROJECT. OTHERWISE OVERCURRENT PROTECTION MIGHT NOT WORK, OR IT MIGHT CAUSE POWER QUALITY PROBLEMS.
- NO ALUMINUM SHALL BE USED FOR GROUNDING WORK WITHOUT THE SPECIFIC WRITTEN PERMISSION OF THE ENGINEER. EXCEPTION: ALUMINUM BUILDING STRUCTURAL MATERIALS SHALL BE BONDED WITH LISTED ALUMINUM EQUIPMENT WITH ALUMINUM TO COPPER CONNECTORS FOR ROUTING COPPER EGC'S.
- PROVIDE GROUNDING BUSHING ON BOTH ENDS OF ALL SERVICE ENTRANCE RACEWAYS, SIZE AS A GEC [250.80]. THIS INCLUDES RIGID STEEL ELBOWS ON PVC CONDUIT.
- ALL METAL ENCLOSURES AND RACEWAYS SHALL BE BONDED TO GROUND [250.86]. FOR CIRCUITS OVER 250V PROVIDE BOND PER [250.97]. STANDARD LOCKNUTS ARE NOT ACCEPTABLE.
- PROVIDE EGC CONNECTED TO ANY JUNCTION BOX WHERE SPLICE IS MADE [250.148].
- PROVIDE BOND TO EXPOSED METAL ON ALL MOTORS, PUMPS, AND LIGHTING FIXTURES PER [250.112].

1 GROUNDING DETAIL
E003 NOT TO SCALE

FIRE ALARM SINGLE-LINE NOTES

- PROVIDE ALL REQUIRED PROGRAMMING, MODIFICATIONS, SOFTWARE, AND HARDWARE AS REQUIRED AT THE EXISTING FIRE ALARM SYSTEM.

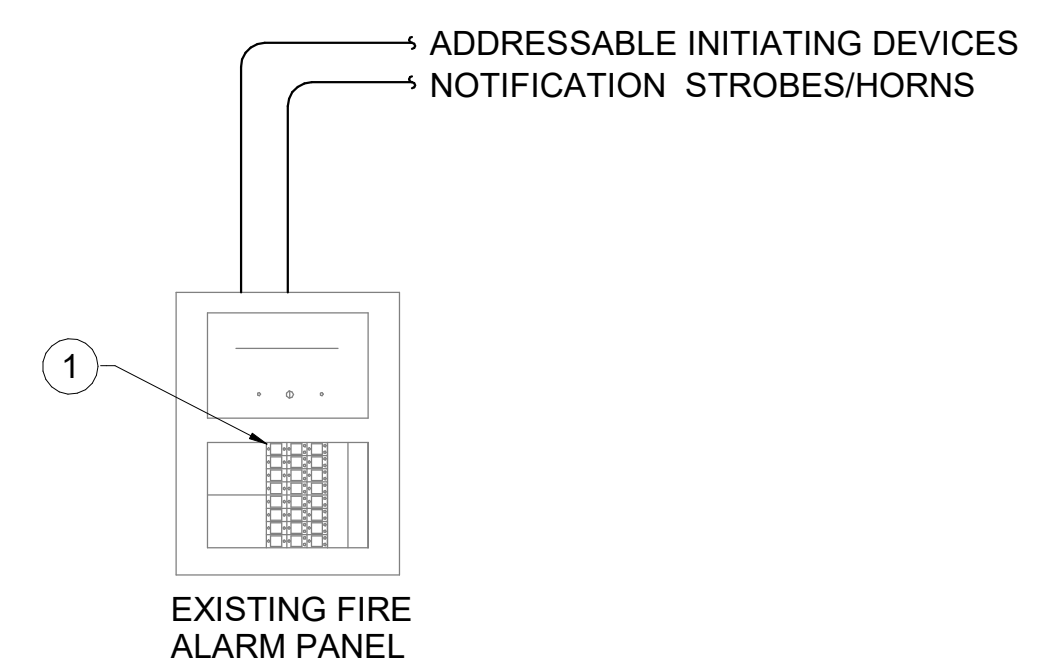

2 FIRE PARTIAL FIRE ALARM RISER DIAGRAM
E003 NOT TO SCALE

FIRE ALARM SYSTEM GENERAL NOTES

- SEE FLOOR PLANS FOR INTENDED COVERAGE OF FIRE ALARM SYSTEM.
- THE FOLLOWING SHALL OCCUR UPON ACTIVATION OF ANY INITIATING DEVICE:
 - SOUND ALL AUDIBLE DEVICES (CHIMES, HORNS, BELLS, ETC.) AND FLASH ALL VISUAL DEVICES (LIGHTS OR STROBES) THROUGHOUT THE ENTIRE FACILITY.
 - ALERT A CENTRAL STATION ALARM REPORTING SERVICE VIA DIGITAL COMMUNICATOR AND LEASED TELEPHONE LINES.
 - CLOSE ALL SMOKE DOORS THROUGHOUT THE FACILITY.
 - STOP OR START AHU'S OR FANS.
 - INDICATE BY ZONE WITH AUDIO/VISUAL SIGNAL AT FACP AND ALL REMOTE ANNUNCIATORS.
- INITIATING DEVICES SHALL BE SMOKE DETECTORS, DUCT-MOUNTED SMOKE DETECTORS, HEAT DETECTORS, MANUAL PULL STATIONS, AND SPRINKLER FLOW SWITCHES.
- ALL SYSTEM WIRING SHALL BE CLASS B, NO T-TAPPING IS PERMITTED.
- PROVIDE BATTERY AND VOLTAGE DROP CALCULATIONS THAT INCLUDE ALL EXISTING AND NEW DEVICES AND APPLIANCES INSTALLED IN SYSTEM AND SUBMIT TO CONTRACTING OFFICER.
- FIRE ALARM SYSTEM CONTROL EQUIPMENT, ALARM INITIATING DEVICES, POWER SOURCES, MUNICIPAL OR REMOTE STATION SIGNALING APPARATUS, SMOKE DOOR HOLD/RELEASE DEVICES, AND REMOTE ANNUNCIATION/CONTROL PANELS (GRAPHIC DISPLAY PANELS EXCLUDED) SHALL BE UNDERWRITER'S LABORATORIES LISTED FOR THE INSTALLED APPLICATION.
- RE-CERTIFY THE SYSTEM IN ACCORDANCE WITH NFPA 71 AFTER ALL WORK IS COMPLETE.
- EXISTING FIRE ALARM SYSTEM IS HONEYWELL AND LOCATED IN MECHANICAL 121.

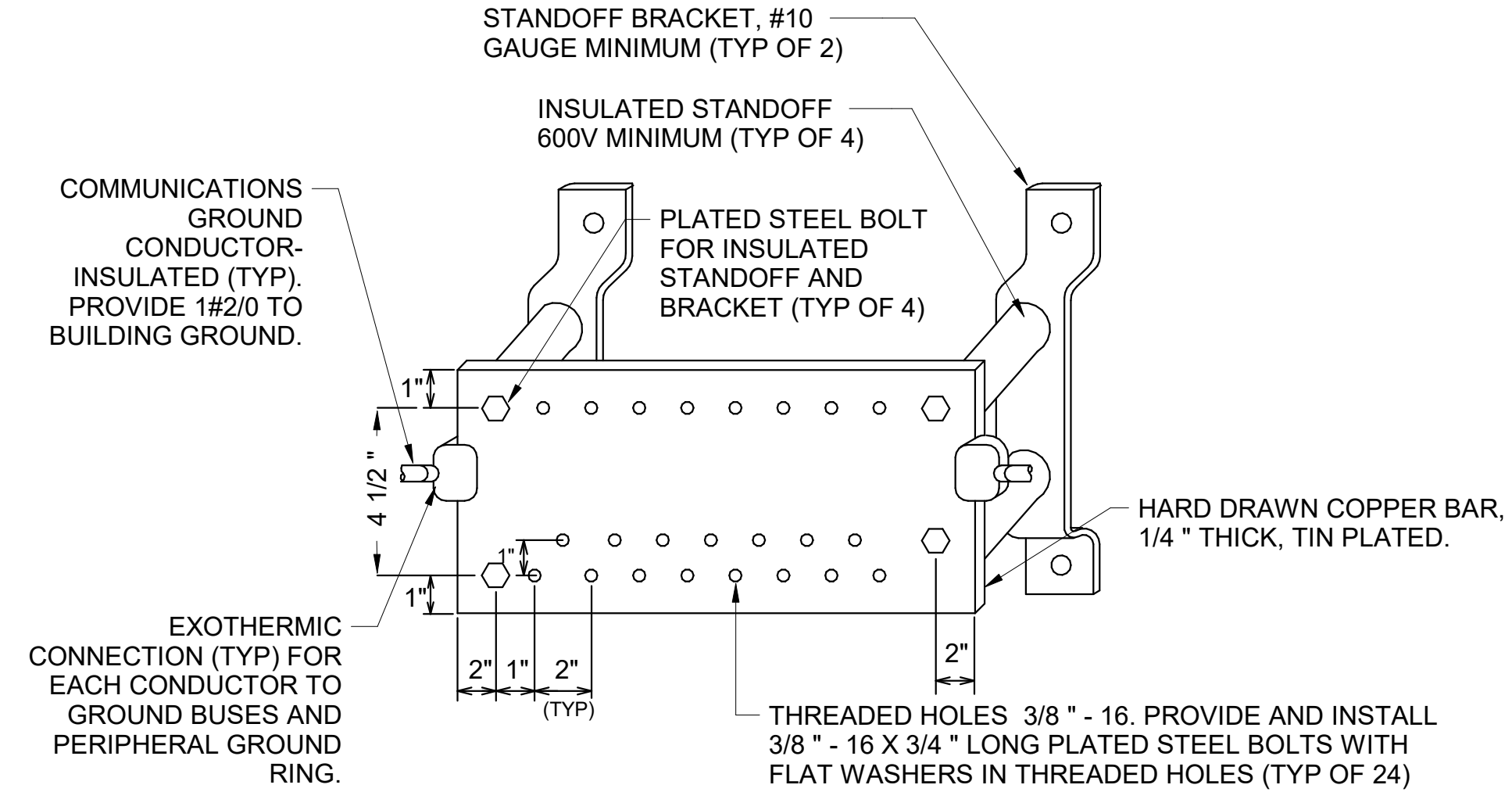

3 TELECOMMUNICATIONS GROUND BUS BAR
E003 NOT TO SCALE

| REV. | DATE | DESCRIPTION |
|------|------|-------------|
| | | |
| | | |
| | | |
| | | |

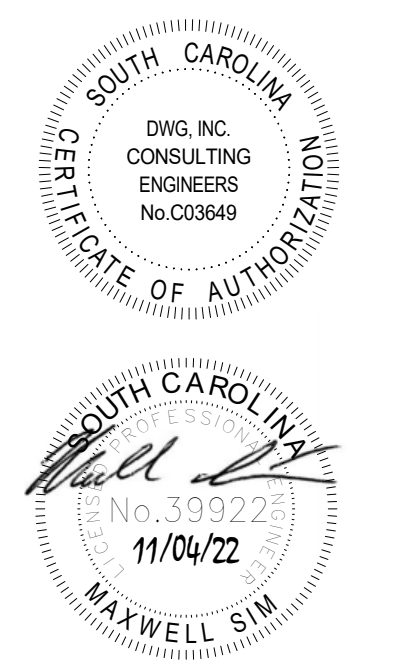

HARRELSON BUILDING IT DEPARTMENT RENOVATION
COLLETON COUNTY
31 KLEIN STREET,
WALTERBORO, SC 29488

COPYRIGHT © GLICKBOEHM & ASSOCIATES, INC.
JOB NUMBER: 19138-00
DRAWN BY: MHS
CHECKED BY: BSB
APPROVED BY: MHS
DATE ISSUED FOR: CONSTRUCTION DOCUMENTS 11/04/22

ELECTRICAL DETAILS

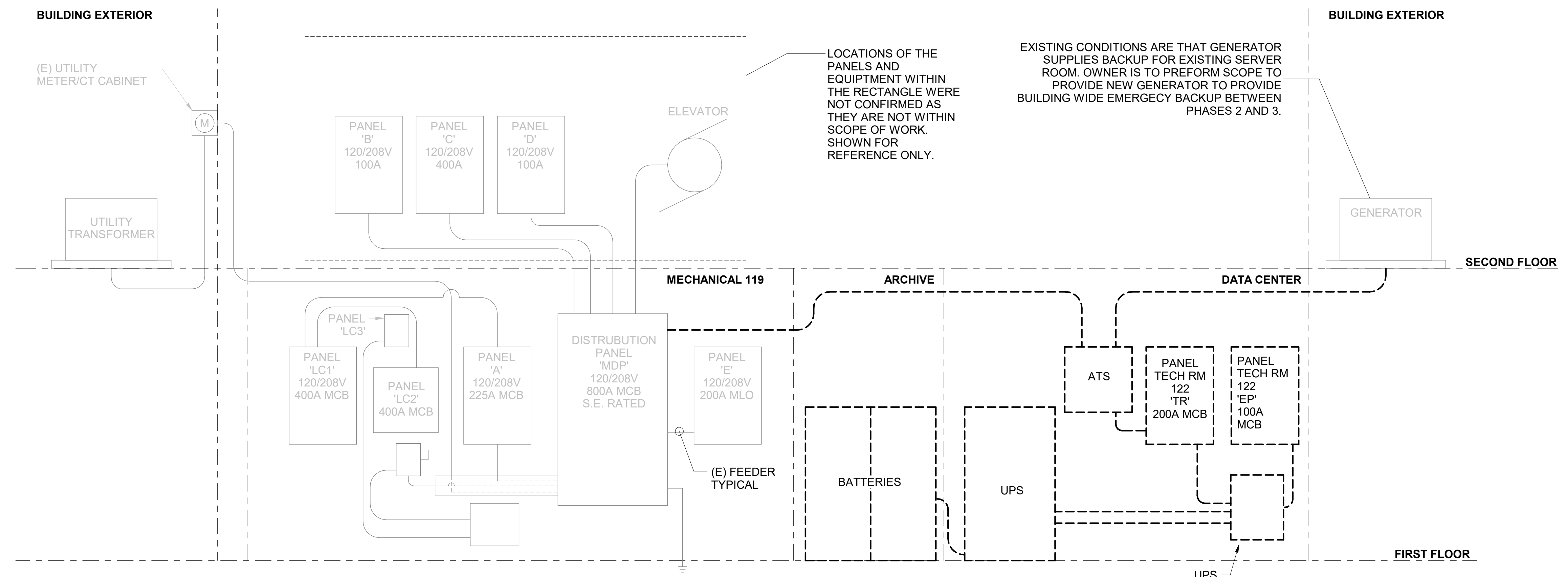

1 EXISTING/PAGE 3 DEMOLITION ELECTRICAL RISER DIAGRAM
E010 NOT TO SCALE

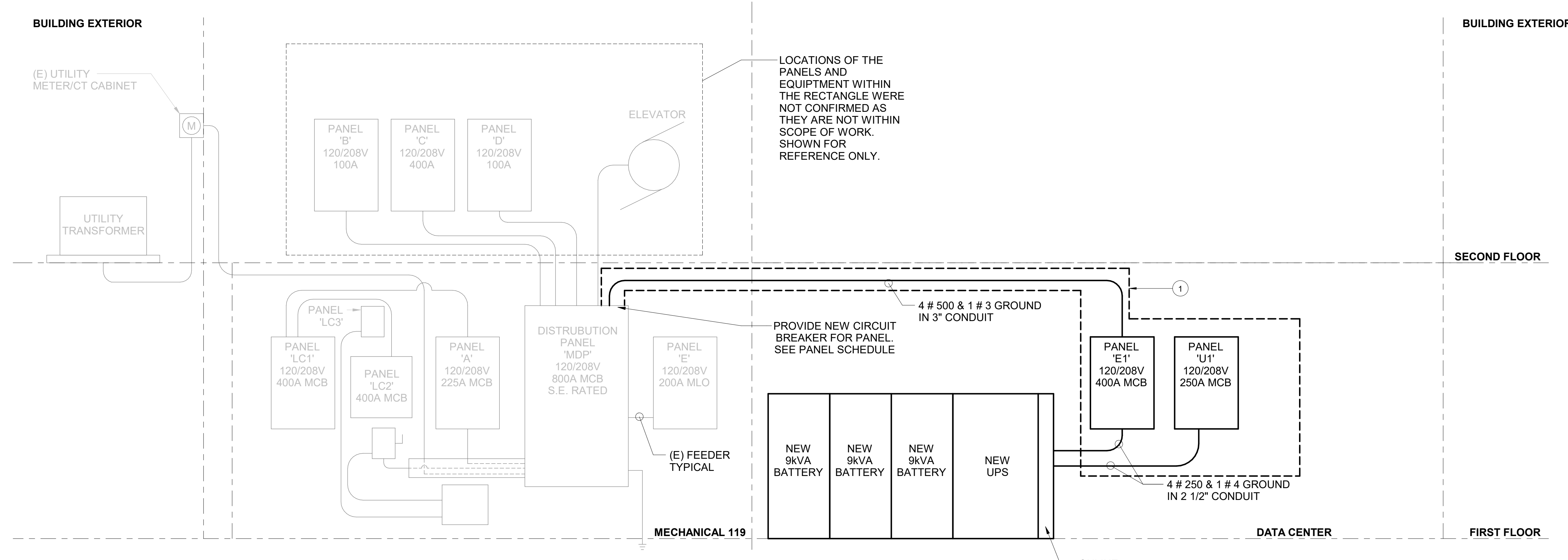

PHASE 3 RENOVATION RISER KEY NOTES
 1 EQUIPMENT AND WIRING FULLY ENCOMPASSED IN SELECTION SHALL BE INSTALLED IN PHASE 2 BUT REMAIN UNENERGIZED UNTIL PHASE 3 WORK HAS BEEN INSTALLED AND CONNECTED.

2 PHASE 3 RENOVATION ELECTRICAL RISER DIAGRAM
E010 NOT TO SCALE

| REV. | DATE | DESCRIPTION |
|------|------|-------------|
| | | |
| | | |
| | | |
| | | |

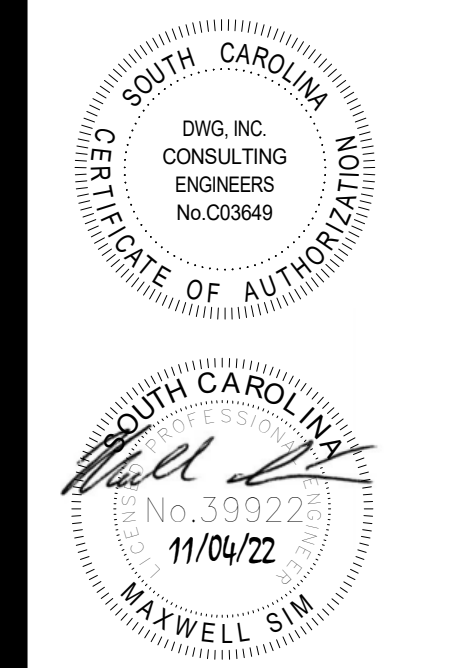

HARRELSON BUILDING IT DEPARTMENT RENOVATION
 COLLETON COUNTY
 31 KLEIN STREET,
 WALTERBORO, SC 29488

COPYRIGHT © GLICK/BOEHM & ASSOCIATES, INC.
 JOB NUMBER: 19138-00
 DRAWN BY: MHS
 CHECKED BY: BSB
 APPROVED BY: MHS
 DATE ISSUED FOR: CONSTRUCTION DOCUMENTS 11/04/22

ELECTRICAL RISER DIAGRAMS

E010

11/4/2022 5:42:31 AM

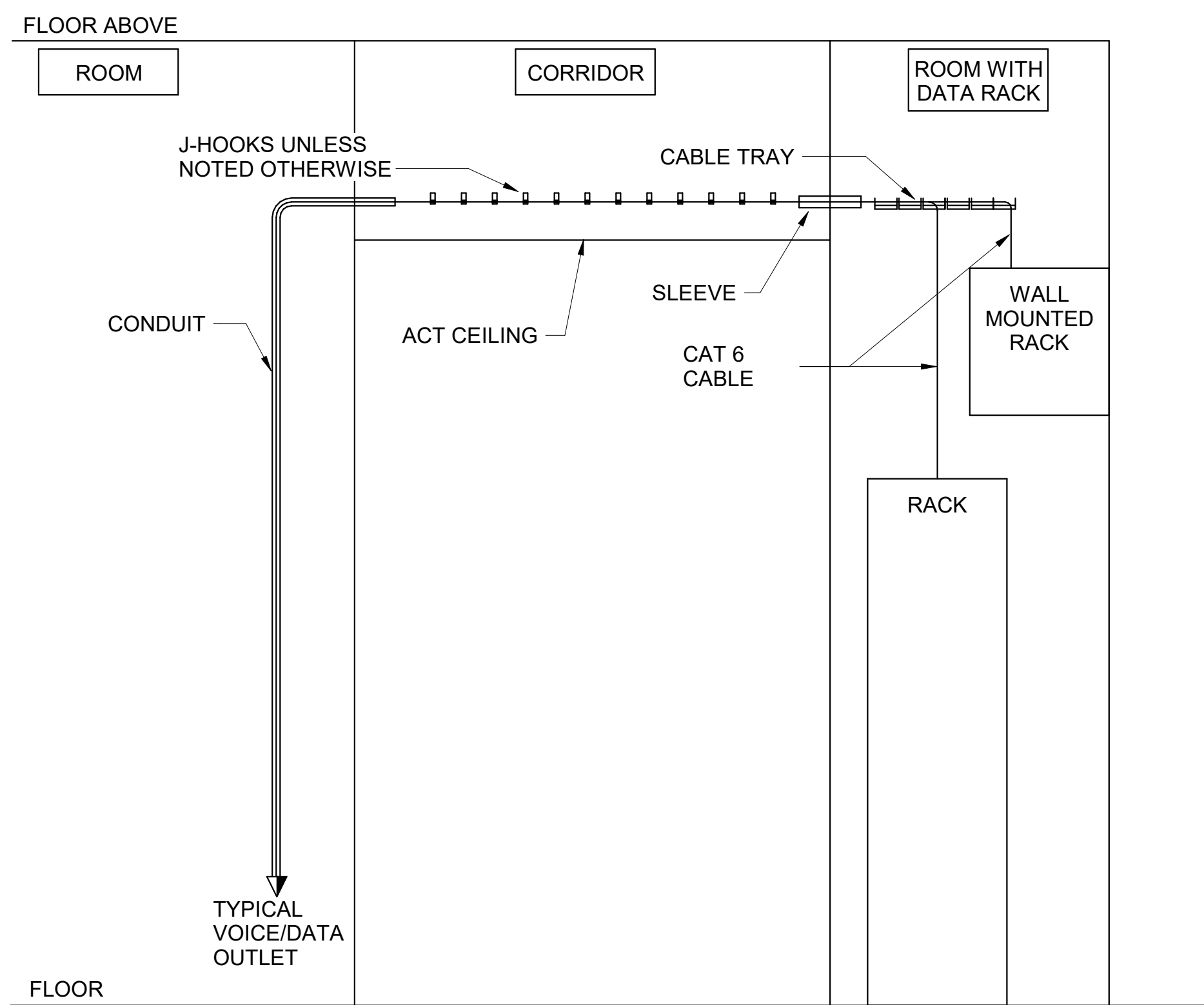

1 COMMUNICATIONS DEVICE RISER
E011 NOT TO SCALE

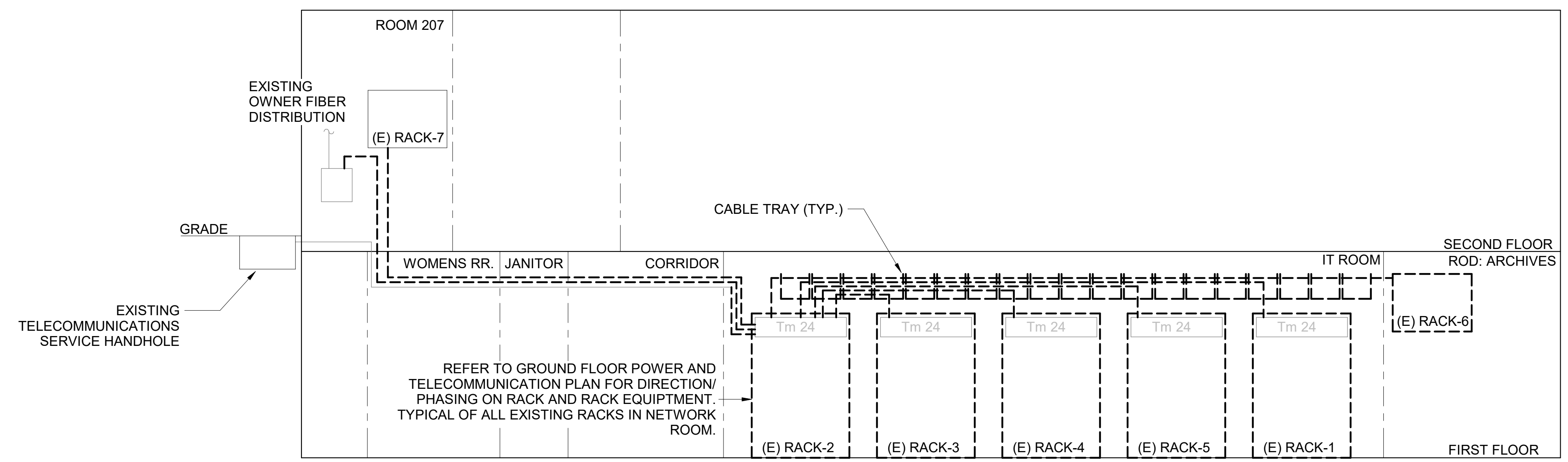

2 EXISTING/DEMOLITION TELECOMMUNICATION RISER DIAGRAM
E011 NOT TO SCALE

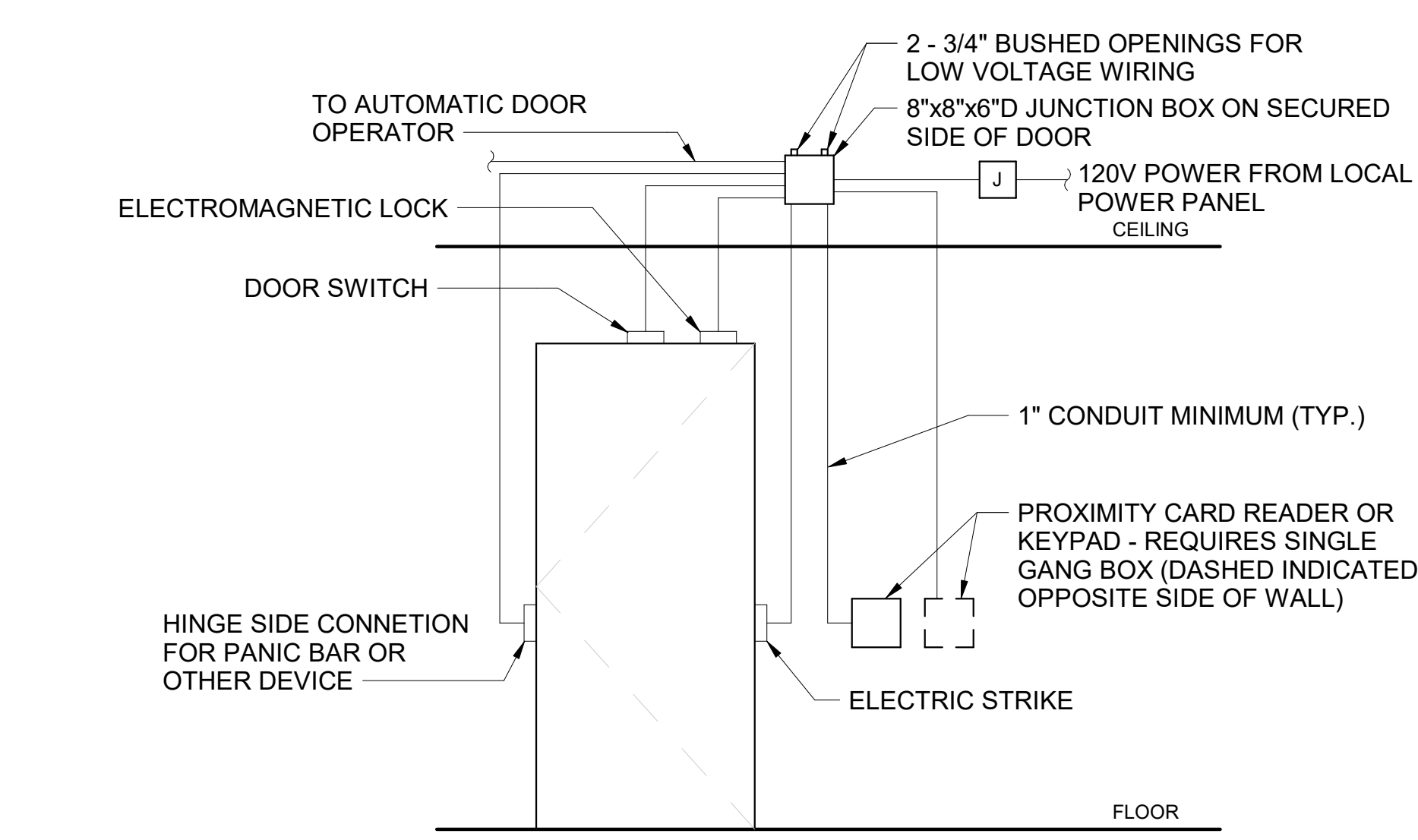

NOTES:
 DOOR ACCESS EQUIPMENT AND LOW VOLTAGE WIRING BY OTHERS. ACTUAL CONFIGURATION AT DOORS WILL VARY BY LOCATION. REFER TO SIGNAL PLANS AND DOOR HARDWARE SPECIFICATION FOR EQUIPMENT AT EACH DOOR. ELECTRICAL CONTRACTOR TO PROVIDE NECESSARY ROUGH-IN: RACEWAYS, BOXES, CONDUCTORS, POWER, ETC. BASED UPON COORDINATION WITH ACCESS CONTROL HARDWARE PROVIDER AND DOOR HARDWARE PROVIDER TO PROVIDE A COMPLETE AND FULLY FUNCTIONAL SYSTEM.
 REFER TO PLAN DRAWINGS FOR WORK APPROPRIATE TO EACH PROJECT AND INTER-RELATIONSHIPS WITH OTHERS. SOME INFORMATION SHOWN HERE IS FOR REFERENCE ONLY.

3 ACCESS CONTROL DOOR ROUGH IN DETAIL
E011 NOT TO SCALE

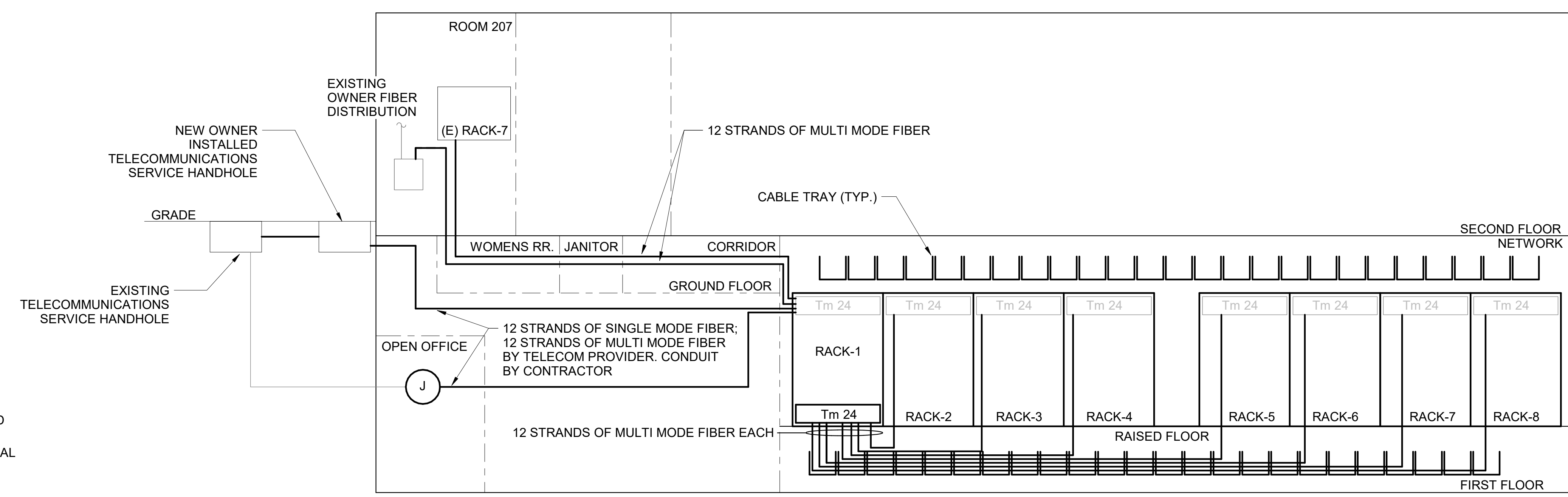

4 RENOVATION TELECOMMUNICATION RISER DIAGRAM
E011 NOT TO SCALE

NOTES:
 1. ALL FIBER STRANDS IN BUILDINGS SHALL TERMINATE IN RACK MOUNTED FIBER PATCH PANELS IN EACH COMMUNICATIONS ROOM. ALL CABLES SHALL BE PLENUM RATED.
 2. TELECOM PROVIDER IS PALMETTO RURAL TELEPHONE COOPERATIVE.

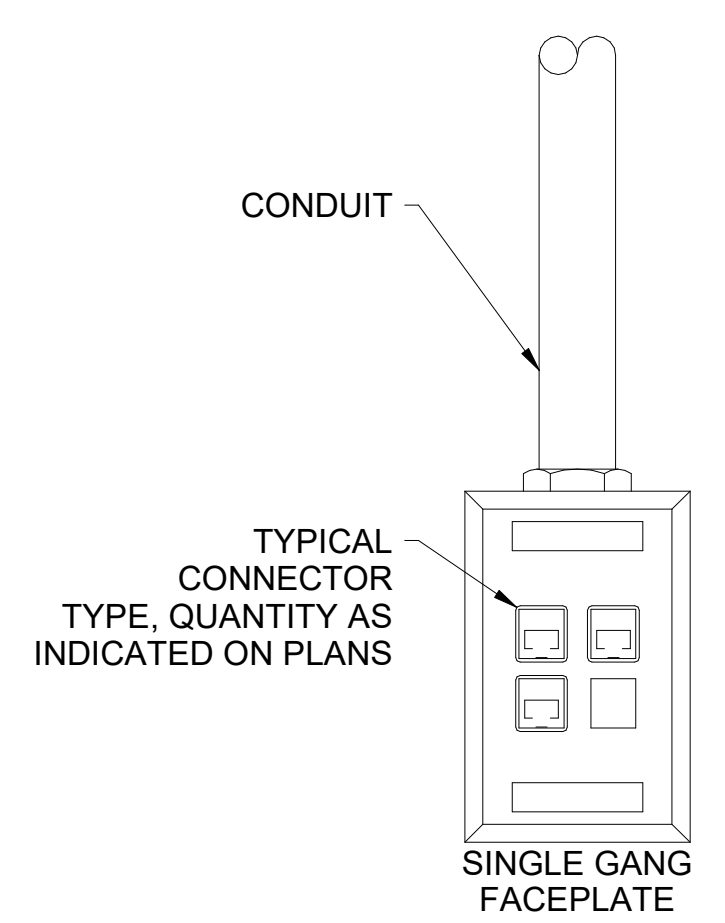

5 COMMUNICATION WALL OUTLET
E011 NOT TO SCALE

| REV. | DATE | DESCRIPTION |
|------|------|-------------|
| | | |
| | | |
| | | |
| | | |
| | | |
| | | |
| | | |
| | | |
| | | |

C:\Users\mjm\Documents\19138-00 Colleton Harrelson Bldg MEP_2020_msimD5AA7.rvt

GENERAL NOTES

1. HATCHED REGION NOT IN PHASE 1 POWER SCOPE OF WORK.

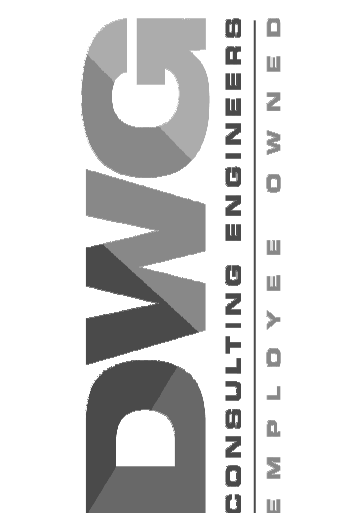

| REV. | DATE | DESCRIPTION |
|------|------|-------------|
| | | |
| | | |
| | | |

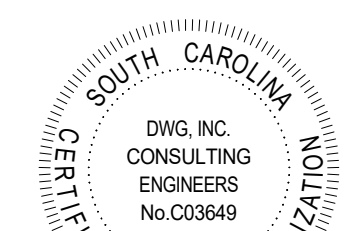

HARRELSON BUILDING IT DEPARTMENT RENOVATION
COLLETON COUNTY
31 KLEIN STREET,
WALTERBORO, SC 29488

COPYRIGHT © GLICK/BOEHM & ASSOCIATES, INC.
JOB NUMBER: 19136-00
DRAWN BY: MHS
CHECKED BY: BSB
APPROVED BY: MHS
DATE ISSUED FOR: CONSTRUCTION DOCUMENTS 11/04/22

FIRST FLOOR POWER PLANS (PHASE 1)

E101

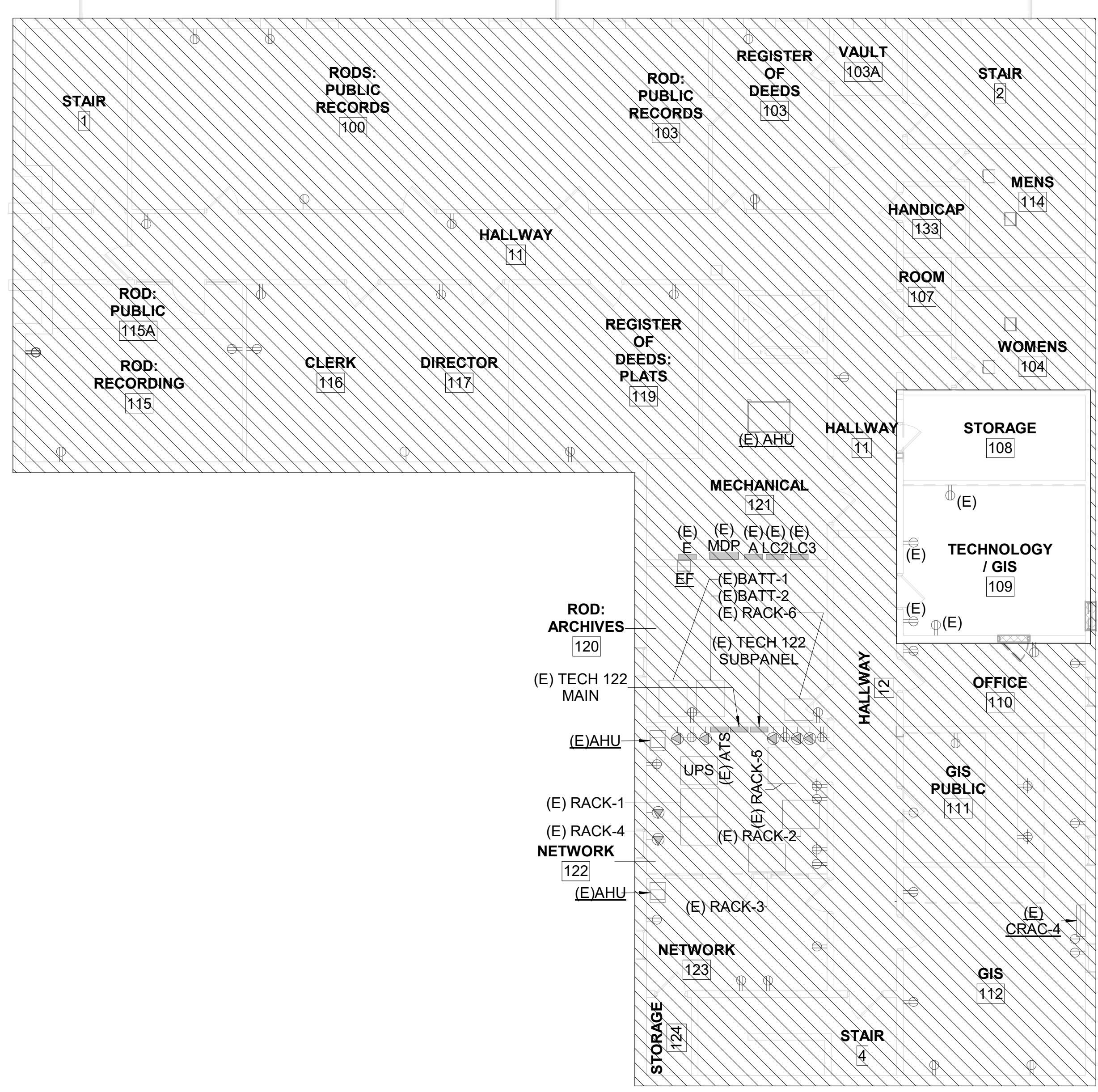

1 FIRST FLOOR POWER DEMOLITION PLAN - PHASE 1
E101 SCALE: 1/8" = 1'-0"

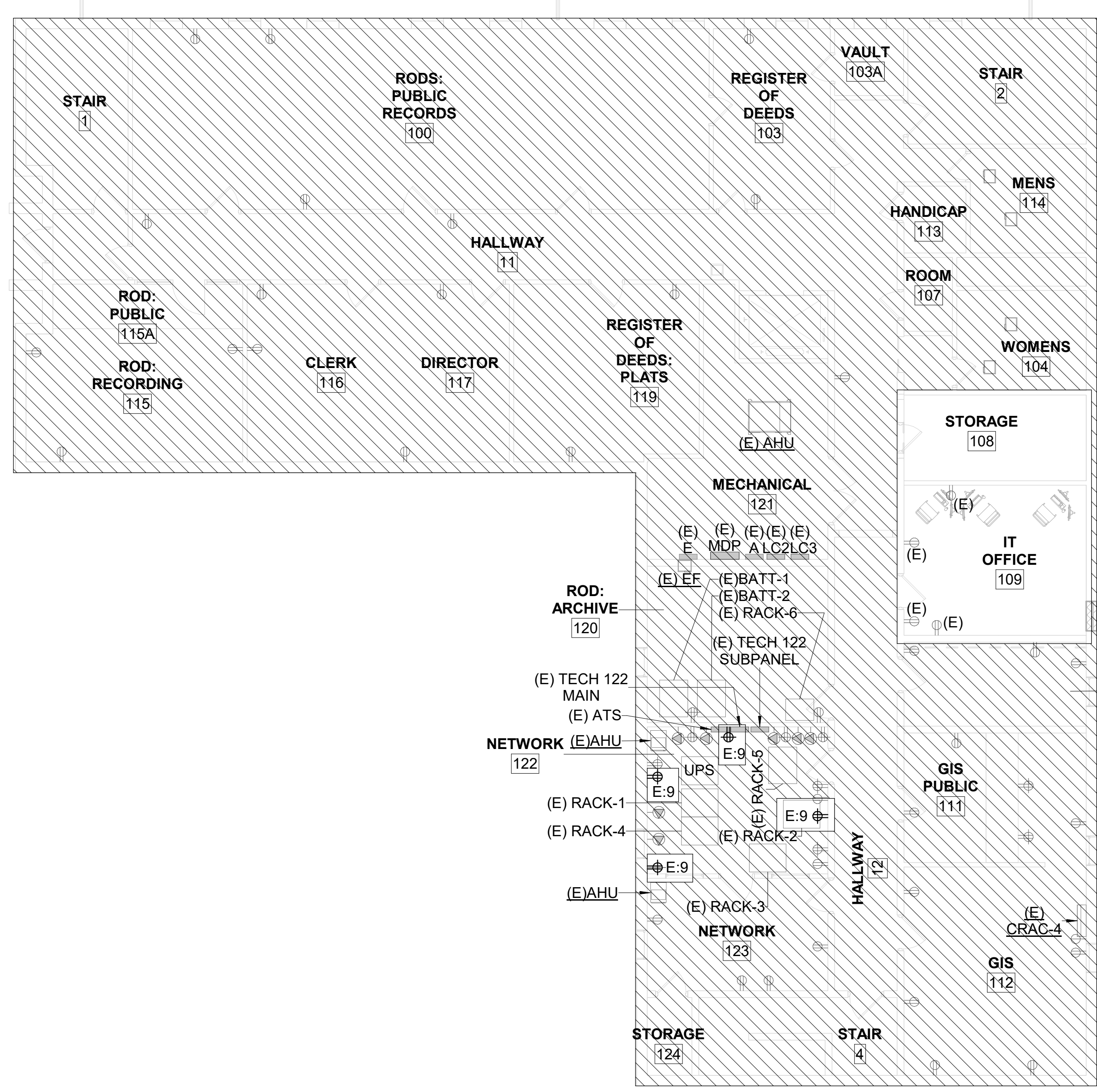

2 FIRST FLOOR POWER RENOVATION PLAN - PHASE 1
E101 SCALE: 1/8" = 1'-0"

DEMOLITION KEYNOTES

- 1 DEMOLISH LIGHT FIXTURE AND ASSOCIATED CONTROLS. REMOVE CONDUIT AND WIRE BACK TO NEAREST JUNCTION BOX.

RENOVATION KEYNOTES

- 1 CONNECT NEW LIGHT FIXTURE TO LIGHTING CIRCUIT MADE AVAILABLE DURING PHASE 1 DEMOLITION.

GENERAL NOTES

- 1. HATCHED REGION NOT IN PHASE 1 LIGHTING SCOPE OF WORK.

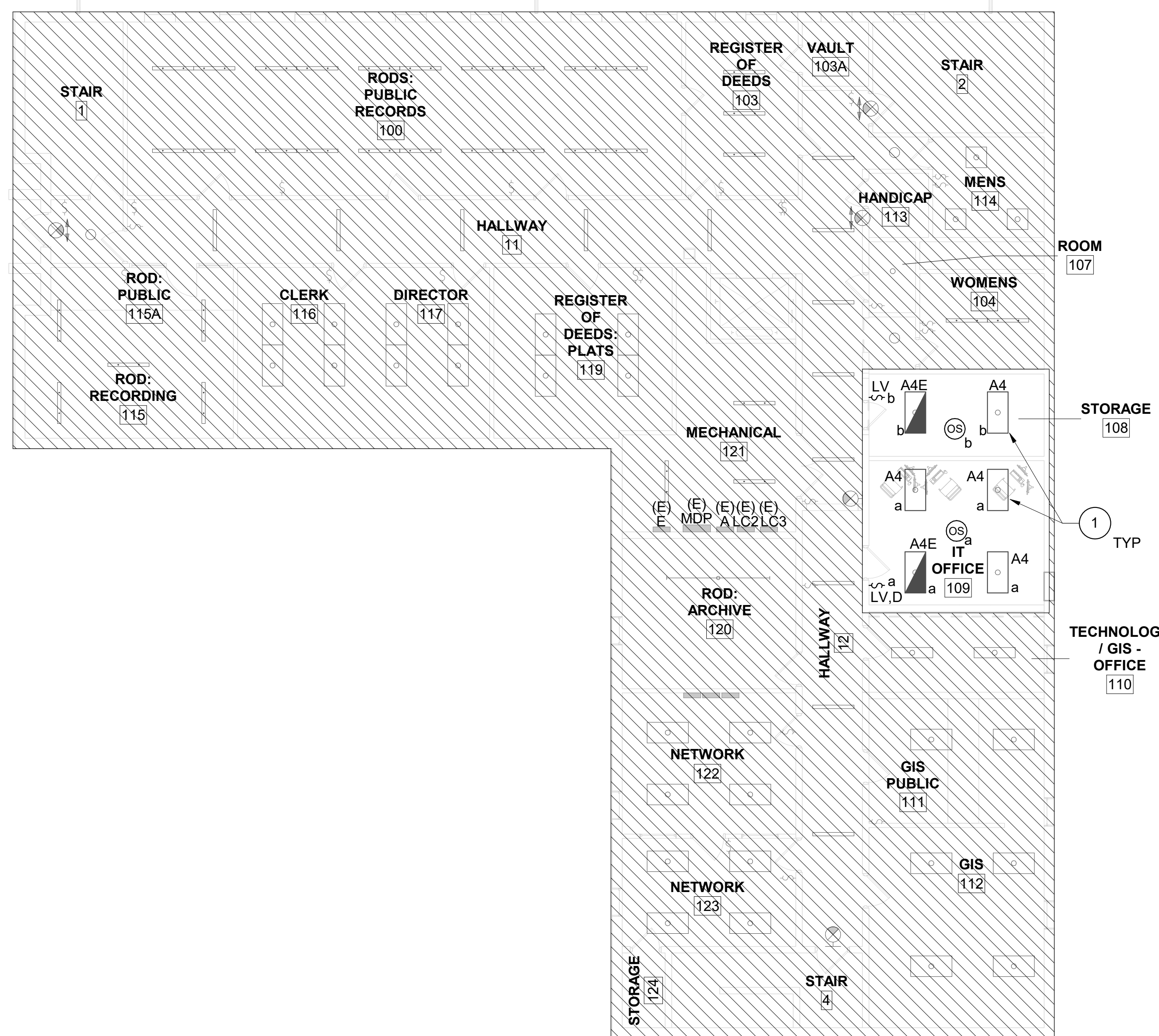
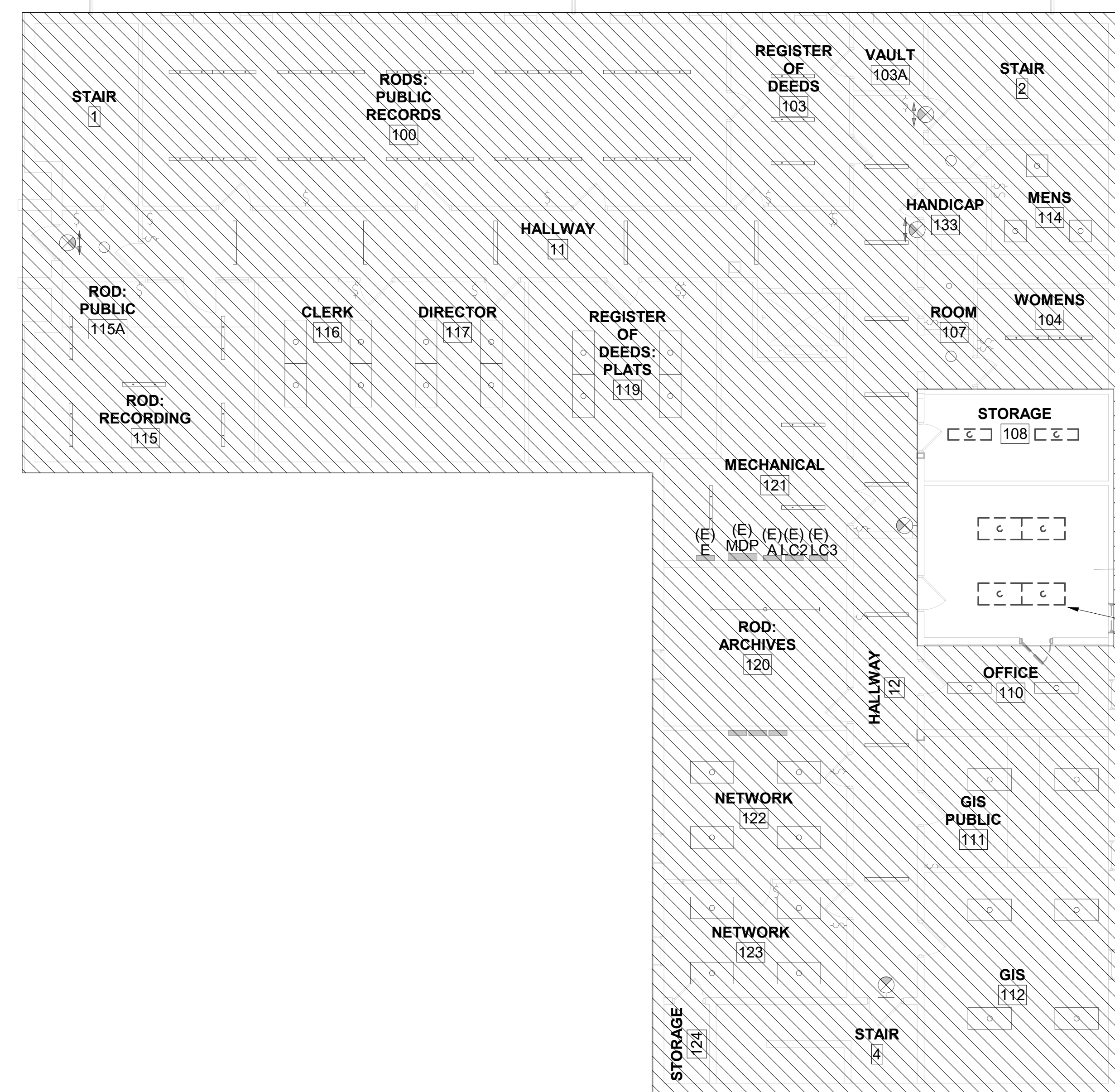
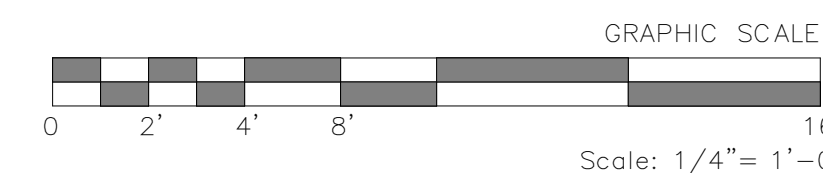

1 GROUND FLOOR LIGHTING DEMOLITION PLAN - PHASE 1
E102 SCALE: 1/8" = 1'-0"

2 GROUND FLOOR LIGHTING RENOVATION PLAN - PHASE 1
E102 SCALE: 1/8" = 1'-0"

| REV. | DATE | DESCRIPTION |
|------|------|-------------|
| | | |
| | | |
| | | |

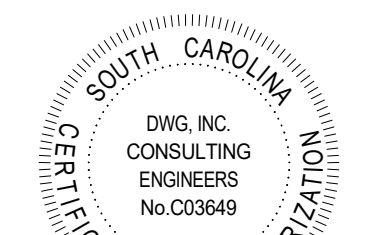

**HARRELSON BUILDING IT
DEPARTMENT
RENOVATION**
COLLETON COUNTY
31 KLEIN STREET,
WALTERBORO, SC 29488

COPYRIGHT ©
GLICKBOEHM & ASSOCIATES, INC.
JOB NUMBER: 19138-00
DRAWN BY: MHS
CHECKED BY: BSB
APPROVED BY: MHS
DATE ISSUED FOR:
CONSTRUCTION DOCUMENTS 11/04/22

FIRST FLOOR
LIGHTING
PLANS (PHASE
1)

E102

RENOVATION KEYNOTES

- 1 PROVIDE 120V POWER FOR DOOR HARDWARE FROM NEAREST RECEPTACLE. COORDINATE INSTALLATION REQUIREMENTS WITH DOOR HARDWARE PROVIDER.

GENERAL NOTES

- 1. ALL NEW FIRE ALARM DEVICES SHALL BE COMPATIBLE WITH EXISTING FIRE ALARM SYSTEM. NEW FIRE ALARM DEVICES SHALL BE TIED BACK INTO EXISTING FIRE ALARM SYSTEM. EXISTING FIRE ALARM CONTROL PANEL IS A FIRE-LITE MS-5UD.
- 2. HATCHED REGION NOT IN PHASE 1 SYSTEMS SCOPE OF WORK.



| REV. | DATE | DESCRIPTION |
|------|------|-------------|
| | | |
| | | |
| | | |
| | | |
| | | |
| | | |
| | | |
| | | |
| | | |
| | | |

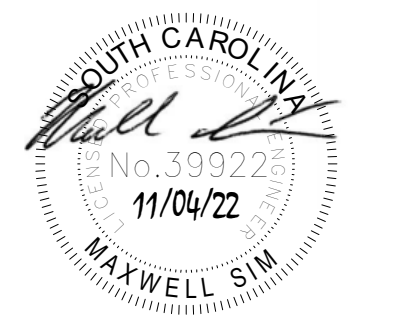
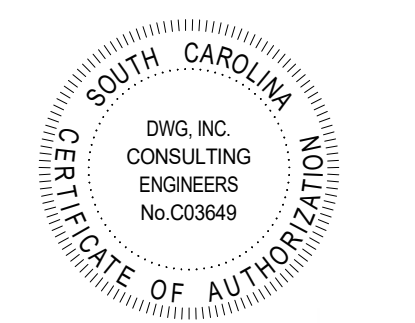

HARRELSON BUILDING IT DEPARTMENT RENOVATION
 COLLETON COUNTY
 31 KLEIN STREET,
 WALTERBORO, SC 29488

COPYRIGHT © GLICK/BOEHM & ASSOCIATES, INC.
 JOB NUMBER: 19136-00
 DRAWN BY: MHS
 CHECKED BY: BSB
 APPROVED BY: MHS
 DATE ISSUED FOR: CONSTRUCTION DOCUMENTS 11/04/22

FIRST FLOOR SYSTEMS PLANS (PHASE 1)
E103



1 FIRST FLOOR SYSTEMS DEMOLITION PLAN - PHASE 1
 E103 SCALE: 1/8" = 1'-0"



2 FIRST FLOOR SYSTEMS RENOVATION PLAN - PHASE 1
 E103 SCALE: 1/8" = 1'-0"

DEMOLITION KEYNOTES

- 1 EXISTING ROUTING OF FIBER SERVICE THROUGH BUILDING TO REMAIN. EXISTING FIBER SERVICE TO ROOM SHALL BE COILED ABOVE CEILING TO BE UTILIZED IN RENOVATION PHASE
- 2 EXISTING CONDUIT PENETRATION TO SECOND FLOOR SHALL REMAIN.

RENOVATION KEYNOTES

GENERAL NOTES

- 1. HATCHED REGION NOT IN PHASE 1 TELECOM SCOPE OF WORK.

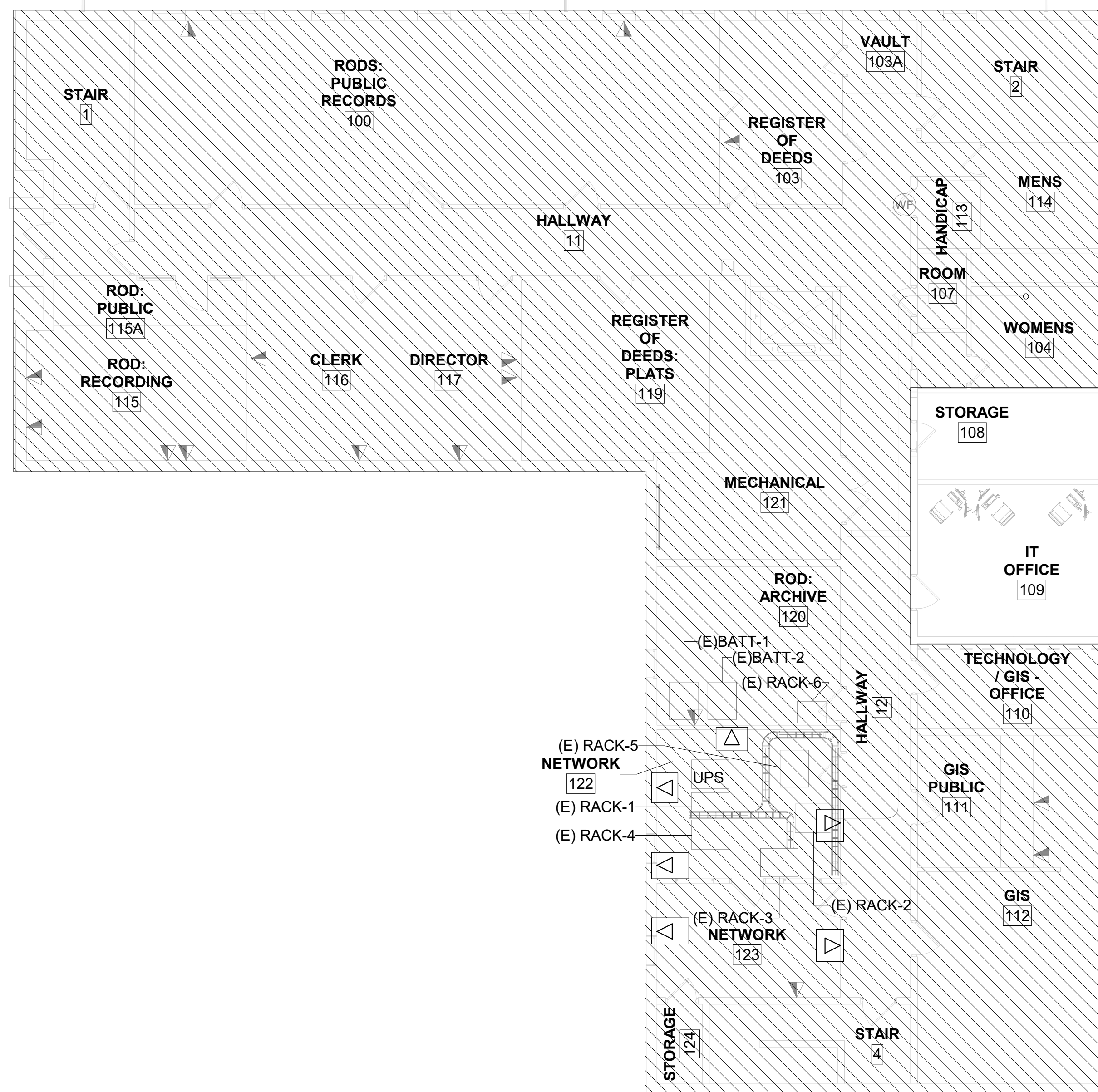
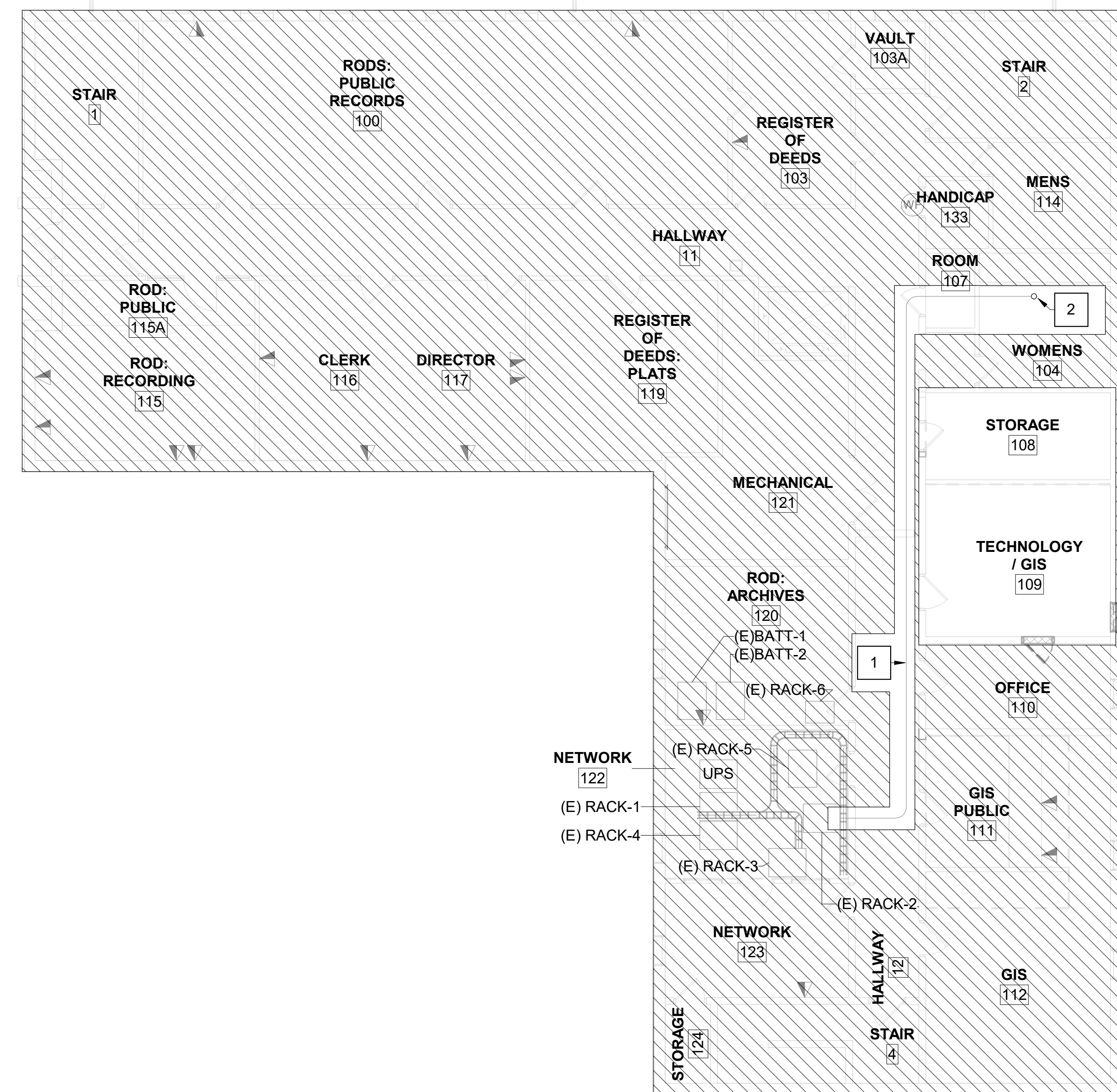

1 FIRST FLOOR TELECOMMUNICATION DEMOLITION PLAN - PHASE 1
E104 SCALE: 1/8" = 1'-0"

2 FIRST FLOOR TELECOMMUNICATION RENOVATION PLAN - PHASE 1
E104 SCALE: 1/8" = 1'-0"



| REV. | DATE | DESCRIPTION |
|------|------|-------------|
| | | |
| | | |
| | | |
| | | |

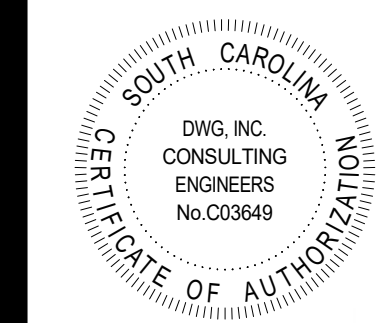

HARRELSON BUILDING IT DEPARTMENT RENOVATION
 COLLETON COUNTY
 31 KLEIN STREET,
 WALTERBORO, SC 29488

COPYRIGHT © GLICK/BOEHM & ASSOCIATES, INC.
 JOB NUMBER: 19138-00
 DRAWN BY: MHS
 CHECKED BY: BSB
 APPROVED BY: MHS
 DATE ISSUED FOR: CONSTRUCTION DOCUMENTS 11/04/22

FIRST FLOOR TELECOM PLAN (PHASE 1)

E104

DEMOLITION KEYNOTES

- 1 DEMOLISH RECEPTACLE. REMOVE CONDUIT AND WIRE BACK TO PANEL.
- 2 DEMOLISH & REMOVE CONDUIT AND WIRE BACK TO PANEL.
- 3 DISCONNECT AND REMOVE DUPLEX. CAP WIRING FOR INSTALLATION OF NEW DUPLEX RECEPTACLE.
- 4 DEMOLISH DISCONNECTS AND ALL CONDUIT AND WIRING TO SOURCE ASSOCIATED WITH CONDENSING UNIT TO BE DEMOLISHED. ANY EXTERIOR PENETRATIONS REMOVED SHALL BE SEALED TO MAINTAIN WALL RATING. FOLLOW MECHANICAL DRAWINGS PHASING FOR DEMOLITION OF UNITS.

RENOVATION KEYNOTES

- 1 RAISED FLOOR SYSTEM AS NOTED BY ARCHITECT.
- 2 INSTALL NEW DUPLEX RECEPTACLE IN EXISTING JUNCTION BOX AND WIRE TO EXISTING WIRING. PROVIDE NEW STAINLESS STEEL COVERPLATE.
- 3 PROVIDE 120V POWER FOR DOOR HARDWARE FROM NEAREST RECEPTACLE. COORDINATE INSTALLATION REQUIREMENTS WITH DOOR HARDWARE PROVIDER.
- 4 CONNECT NEW WATER COOLER TO EXISTING CIRCUIT. PROVIDE DUPLEX GFCI RECEPTACLE IN EXISTING LOCATION.
- 5 EXTERIOR RECEPTACLE AND MECHANICAL EQUIPMENT SHALL BE INSTALLED OUTSIDE ON GROUND LEVEL WHICH IS BETWEEN THE FIRST AND SECOND FLOORS.

GENERAL NOTES

- 1. PROVIDE L6-30R FOR ALL SPECIAL RECEPTACLES SHOWN ON PLAN. PROVIDE 2 #10, #10 G IN 1/2" CONDUIT.
- 2. MAINTAIN CIRCUIT CONTINUITY FOR ANY CIRCUIT WHERE DEVICES ARE DEMOLISHED BUT THE ENTIRE CIRCUIT IS NOT.
- 3. WHERE DEVICES ARE REMOVED IN EXISTING WALLS TO REMAIN, PATCH WALL TO MATCH FINISH AS REQUIRED. HATCHED REGION NOT IN PHASE 2 POWER SCOPE OF WORK.
- 5. ALL UPS BACKUP CONDUITS SHALL BE COLOR CODED AS ORANGE, WITH RED RECEPTACLES, AND JUNCTION BOXES LABELED 'UPS'.

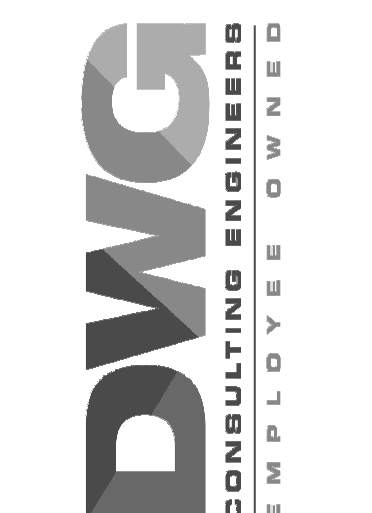

| REV. | DATE | DESCRIPTION |
|------|------|-------------|
| | | |
| | | |
| | | |
| | | |
| | | |



HARRELSON BUILDING IT DEPARTMENT RENOVATION
 COLLETON COUNTY
 31 KLEIN STREET,
 WALTERBORO, SC 29488

COPYRIGHT © GLICKBOEHM & ASSOCIATES, INC.
 JOB NUMBER: 19138-00
 DRAWN BY: MHS
 CHECKED BY: BSB
 APPROVED BY: MHS
 DATE ISSUED FOR: CONSTRUCTION DOCUMENTS
 11/04/22

FIRST FLOOR POWER PLAN (PHASE 2)

E201

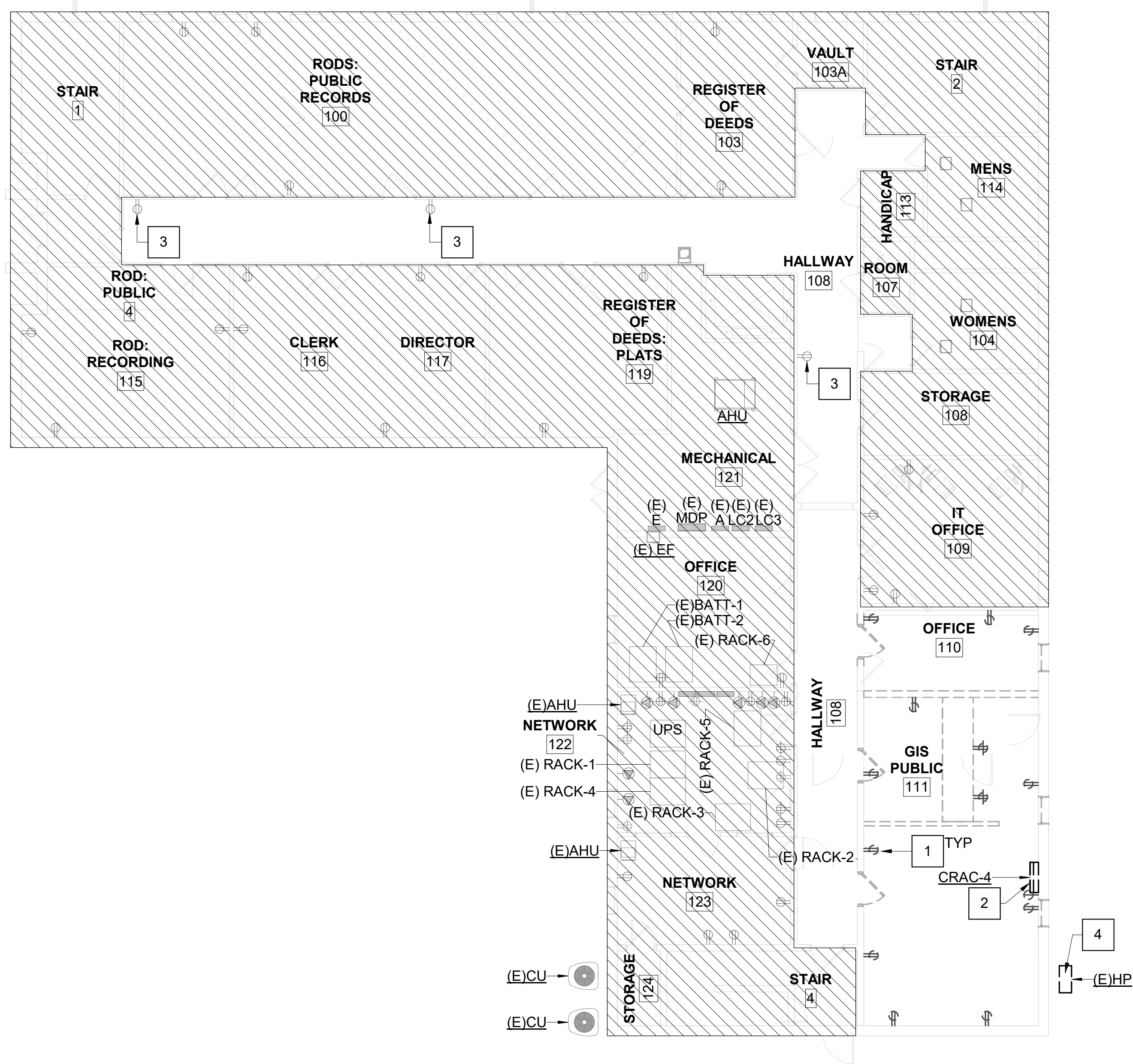

1 FIRST FLOOR POWER DEMOLITION PLAN - PHASE 2
 E201 SCALE: 1/8" = 1'-0"

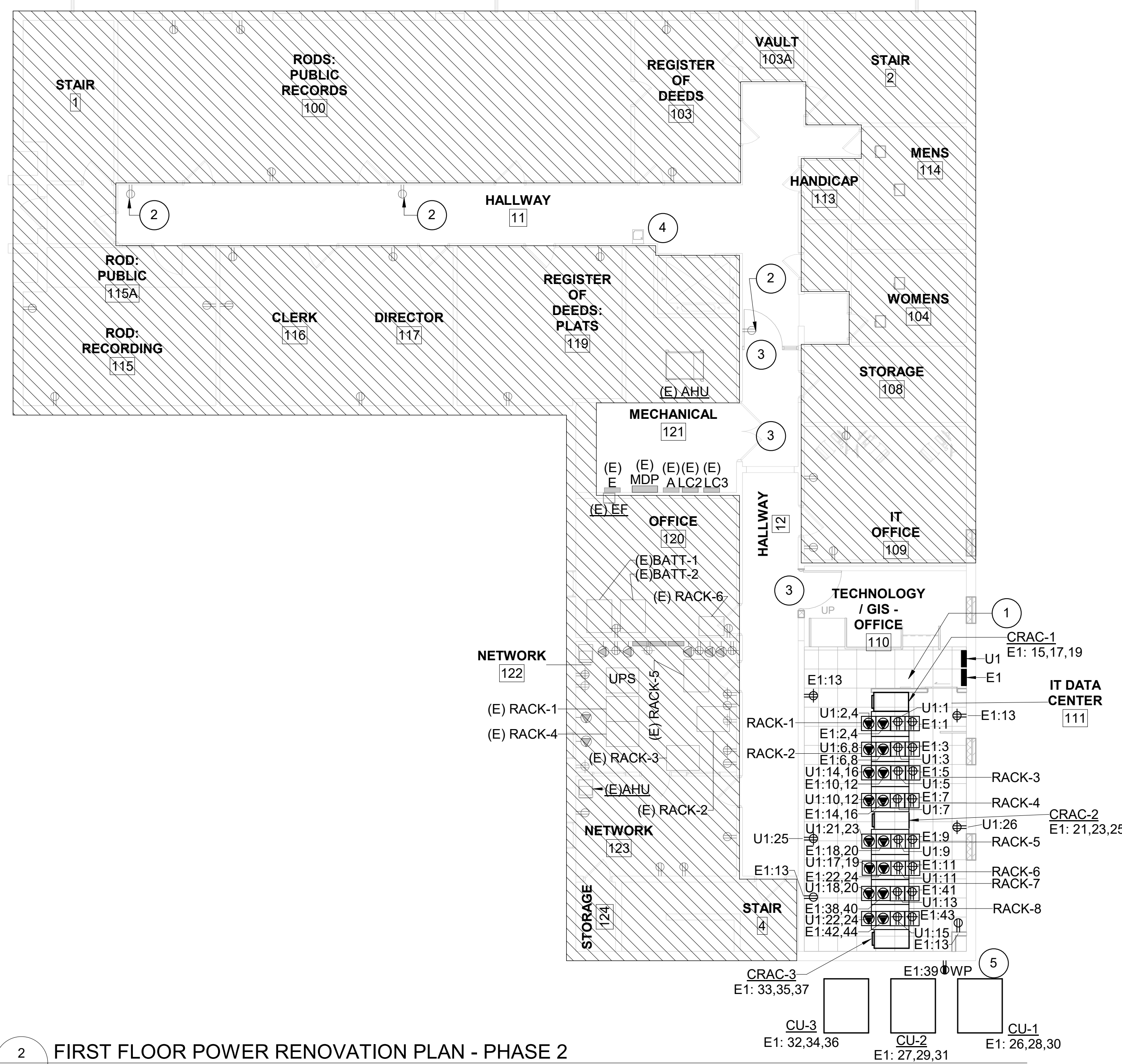

2 FIRST FLOOR POWER RENOVATION PLAN - PHASE 2
 E201 SCALE: 1/8" = 1'-0"

DEMOLITION KEYNOTES

- 1 DEMOLISH LIGHT FIXTURE AND ASSOCIATED CONTROLS. REMOVE CONDUIT AND WIRE BACK TO NEAREST JUNCTION BOX.

RENOVATION KEYNOTES

- 1 CONNECT NEW LIGHT FIXTURE TO LIGHTING CIRCUIT MADE AVAILABLE DURING PHASE 2 DEMOLITION.

GENERAL NOTES

- 1. CONNECT NEW LIGHT FIXTURE TO LIGHTING CIRCUIT MADE AVAILABLE DURING PHASE 2 DEMOLITION.
- 2. HATCHED REGION NOT IN PHASE 2 LIGHTING SCOPE OF WORK.

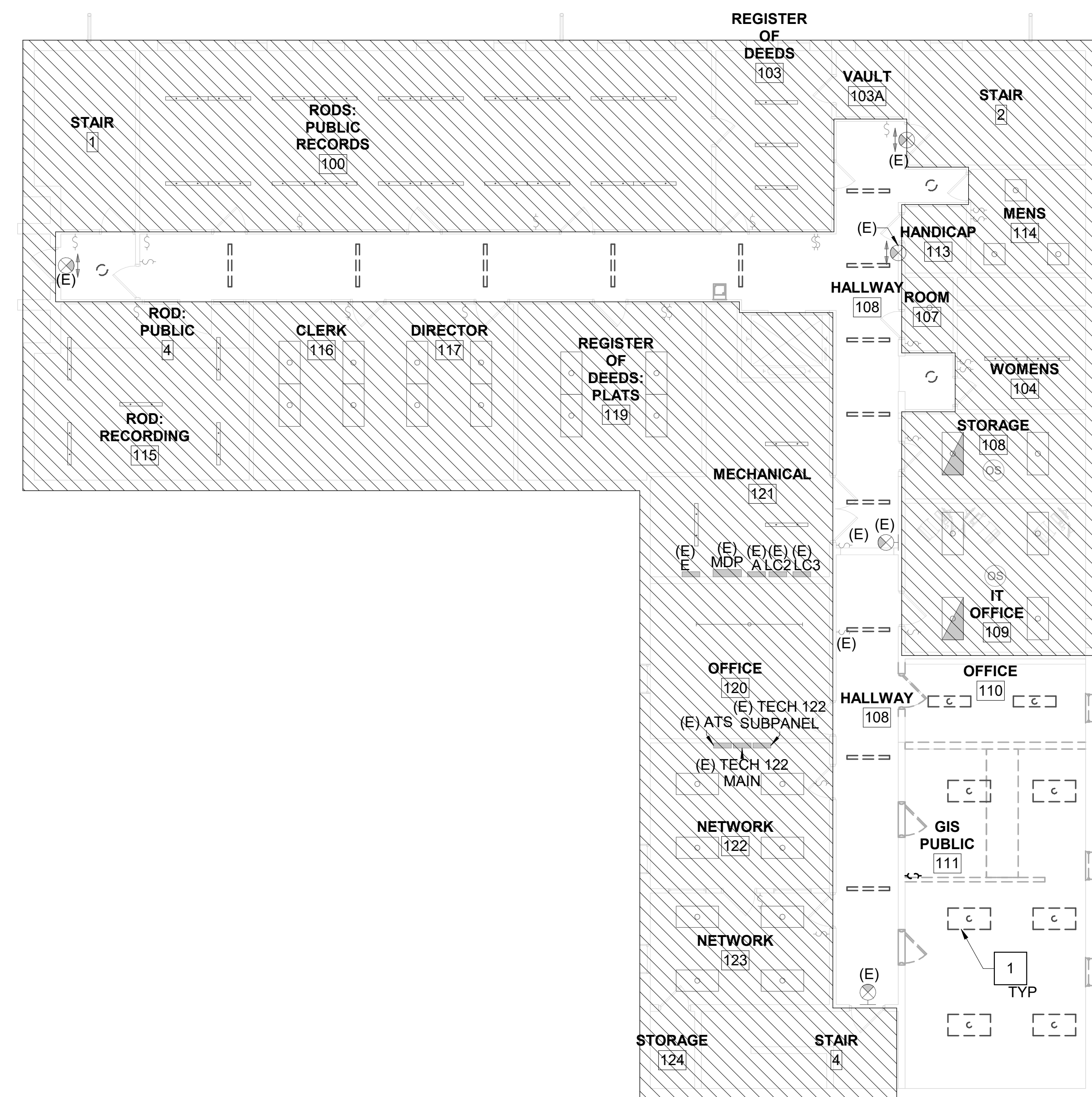
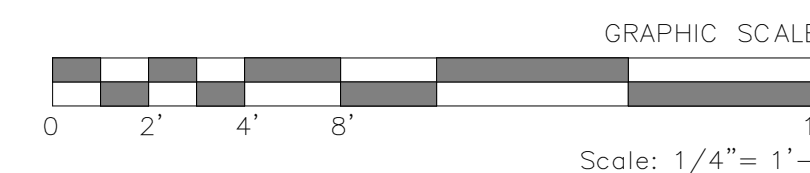

1 FIRST FLOOR LIGHTING DEMOLITION PLAN - PHASE 2
E202 SCALE: 1/8" = 1'-0"

2 FIRST FLOOR LIGHTING RENOVATION PLAN - PHASE 2
E202 SCALE: 1/8" = 1'-0"

| REV. | DATE | DESCRIPTION |
|------|------|-------------|
| | | |
| | | |
| | | |

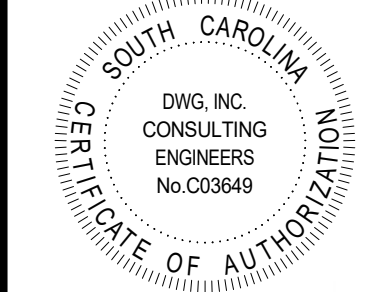

**HARRELSON BUILDING IT
DEPARTMENT
RENOVATION**
COLLETON COUNTY
31 KLEIN STREET,
WALTERBORO, SC 29488

COPYRIGHT ©
GLICKBOEHM & ASSOCIATES, INC.
JOB NUMBER: 19136-00
DRAWN BY: MHS
CHECKED BY: BSB
APPROVED BY: MHS
DATE ISSUED FOR:
CONSTRUCTION DOCUMENTS 11/04/22

**FIRST FLOOR
LIGHTING PLAN
(PHASE 2)**

E202

DEMOLITION KEYNOTES

- 1 EXISTING DEVICES IN CEILING SHALL BE TEMPORARILY REMOVED TO ALLOW CEILING REPLACEMENT, AND SHALL BE RE-INSTALLED IN NEW CEILING. HANDLE DEVICES WITH CARE, THEY SHALL BE RE-INSTALLED IN WORKING ORDER AND IN THE SAME CONDITION AS EXISTING. (TYPICAL)

RENOVATION KEYNOTES

- 1 SMOKE DETECTORS LOCATED UNDER FLOOR IN IT DATA CENTER.

GENERAL NOTES

- 1. ALL NEW FIRE ALARM DEVICES SHALL BE COMPATIBLE WITH EXISTING FIRE ALARM SYSTEM. NEW FIRE ALARM DEVICES SHALL BE TIED BACK INTO EXISTING FIRE ALARM SYSTEM. EXISTING FIRE ALARM CONTROL PANEL IS A FIRE-LITE MS-5UD.
- 2. HATCHED REGION NOT IN PHASE 2 SYSTEMS SCOPE OF WORK.



GLICK BOEHM ARCHITECTURE
ARCHITECTURE PLANNING INTERIOR DESIGN
493 King Street, Suite 100 Charleston, South Carolina 29403
784.577.6377 www.glickboehm.com

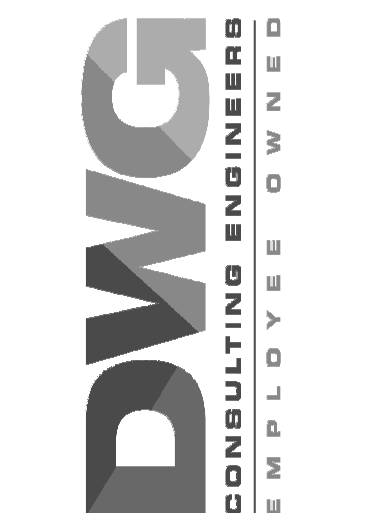

DWG CONSULTING ENGINEERS
EMPLOYEE OWNED

| REV. | DATE | DESCRIPTION |
|------|------|-------------|
| | | |
| | | |
| | | |
| | | |



HARRELSON BUILDING IT DEPARTMENT RENOVATION
COLLETON COUNTY
31 KLEIN STREET,
WALTERBORO, SC 29488

COPYRIGHT © GLICK/BOEHM & ASSOCIATES, INC.
JOB NUMBER: 19136-00
DRAWN BY: MHS
CHECKED BY: BSB
APPROVED BY: MHS
DATE ISSUED FOR: CONSTRUCTION DOCUMENTS 11/04/22

FIRST FLOOR SYSTEMS PLAN (PHASE 2)

E203

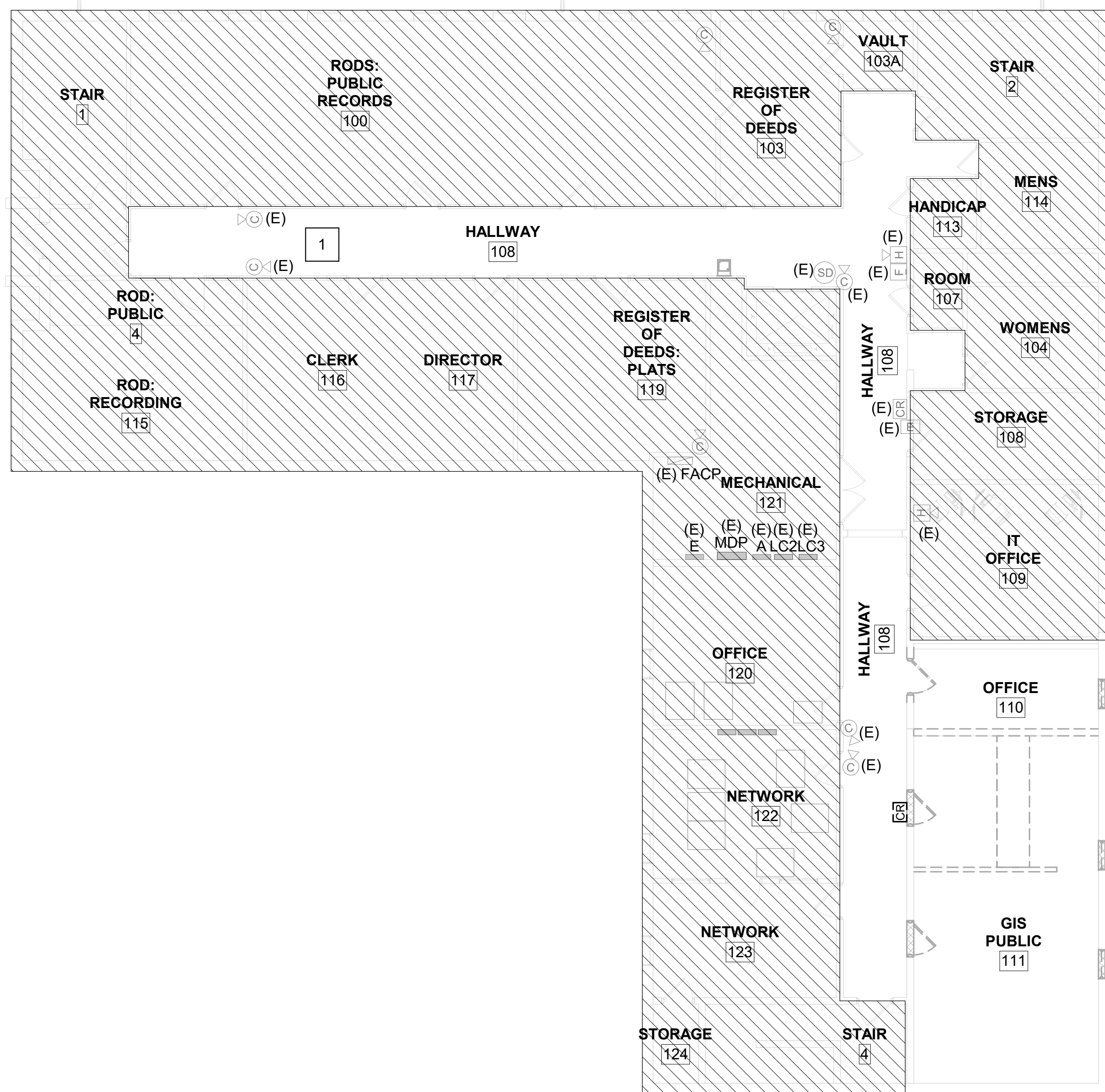

1 FIRST FLOOR SYSTEMS DEMOLITION PLAN - PHASE 2
E203 SCALE: 1/8" = 1'-0"

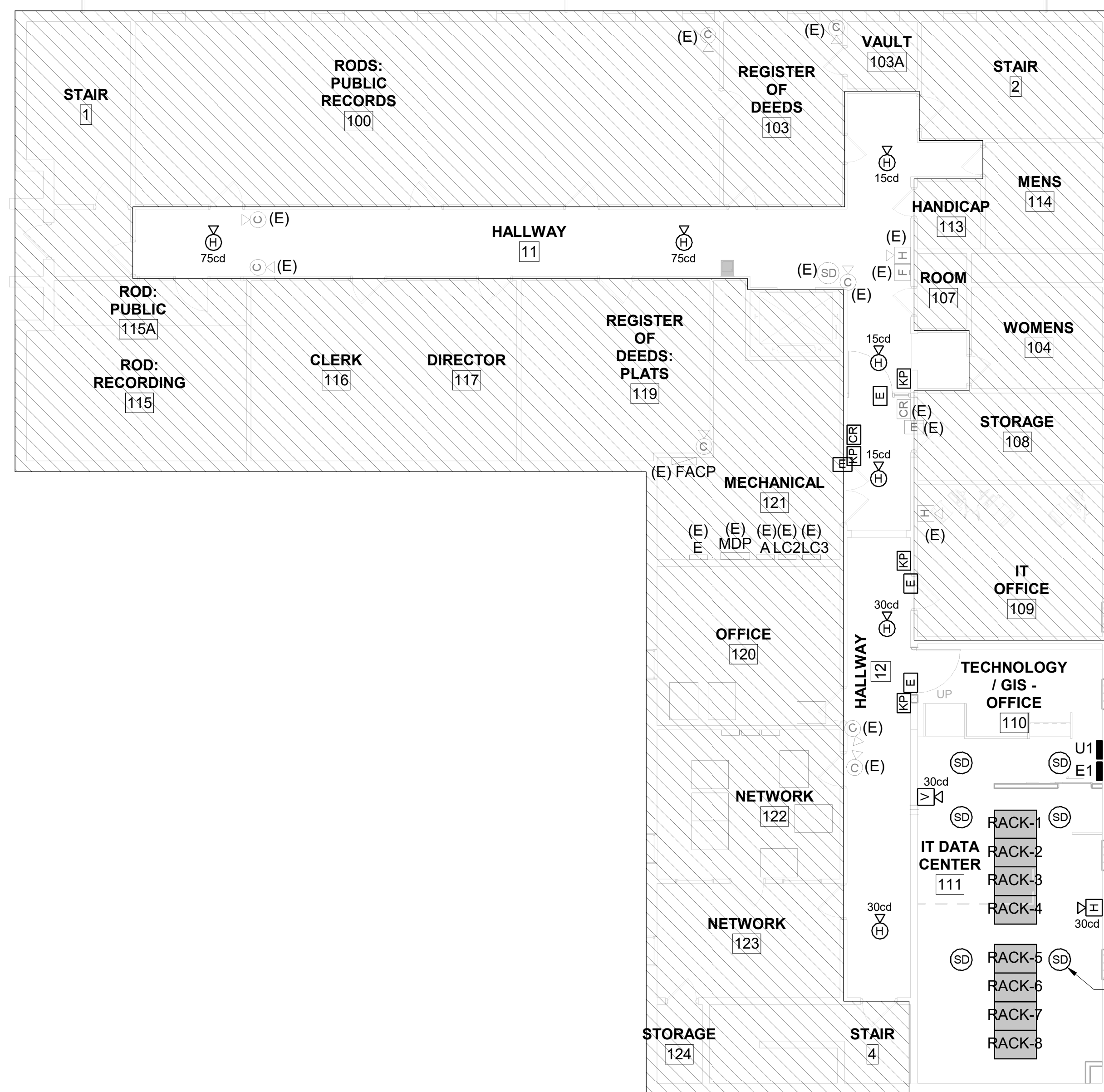

2 FIRST FLOOR SYSTEMS RENOVATION PLAN - PHASE 2
E203 SCALE: 1/8" = 1'-0"

RENOVATION KEYNOTES

- 1 NEW TELECOMMUNICATIONS HANDHOLE INSTALLED BY OWNER PRIOR TO PROJECT. PROVIDE (3) 4" CONDUITS FROM HANDHOLE TO NEW DATA CENTER AS SHOWN. FIELD CONFIRM EXACT HANDHOLE LOCATION PRIOR TO ROUTING CONDUIT NOTIFY ENGINEER IF CONDUIT ROUTING NEEDS TO BE MODIFIED TO ENTER NEW DATA CENTER ON GROUND FLOOR
- 2 PROVIDE (4) 6" CONDUIT SLEEVES THROUGH WALL AT 6" ABOVE HALLWAY FINISHED CEILING.
- 3 EXISTING CONDUIT PENETRATION TO FIRST FLOOR IT DISTRIBUTION. CONTRACTOR SHALL ENLARGE THE EXISTING CONDUIT PENETRATION TO 4" DIAMETER TO ROUTE FIBER TO FIRST FLOOR IT DISTRIBUTION.
- 4 ROUTING OF INTERCONNECTING FIBER BETWEEN IT ROOM AND FIRST FLOOR IT DISTRIBUTION. REFER TO TELECOMMUNICATIONS RISER DIAGRAM FOR CABLING AND CONDUIT SPECIFICATIONS.
- 5 CABLE TRAY HORIZONTAL RUN SHALL BE IN LINE WITH TELECOM SERVICE ENTRY PENETRATION.
- 6 RACK CONTAINMENT SYSTEM. ASM OR EQUAL. PROVIDE 2'X6" HARD ROOF WITH CLEAR DROP AWAY TILES AND RACK AND WALL MOUNTING RAILS. PROVIDE 36" CLEAR SLIDING DOOR ON FRONT ACCESS OF HOT AISLE. RAISED FLOOR SYSTEM UNDERNEATH CONTAINMENT SYSTEM SHALL MAINTAIN THERMAL INTEGRITY OF HOT AISLE.
- 7 PROVIDE JUNCTION BOX ABOVE CEILING CONNECTED TO EXISTING FIBER SERVICE CONDUIT. FIBER SPLICE KIT SHALL BE PROVIDED IN JUNCTION BOX AND NEW FIBER SHALL BE RUN IN 1" CONDUIT FROM JUNCTION BOX LOCATION TO NEW DATA ROOM AS SHOWN. FIBER WILL BE PROVIDED BY UTILITY COMPANY.
- 8 LOCATION OF EXISTING TELECOMMUNICATIONS ENTRY HANDHOLE. HAND HOLE SHALL BE MODIFIED TO FEED NEW TELECOMMUNICATIONS HANDHOLE AS SHOWN. PROVIDE 3" BETWEEN HANDHOLES ROUTING AS SHOWN. EXISTING BUILDING FIBER SERVICE TO REMAIN.

GENERAL NOTES

1. NEW CABLE TRAY TO BE MOUNTED AT 9'.
2. HATCHED REGION NOT IN PHASE 2 TELECOM SCOPE OF WORK.

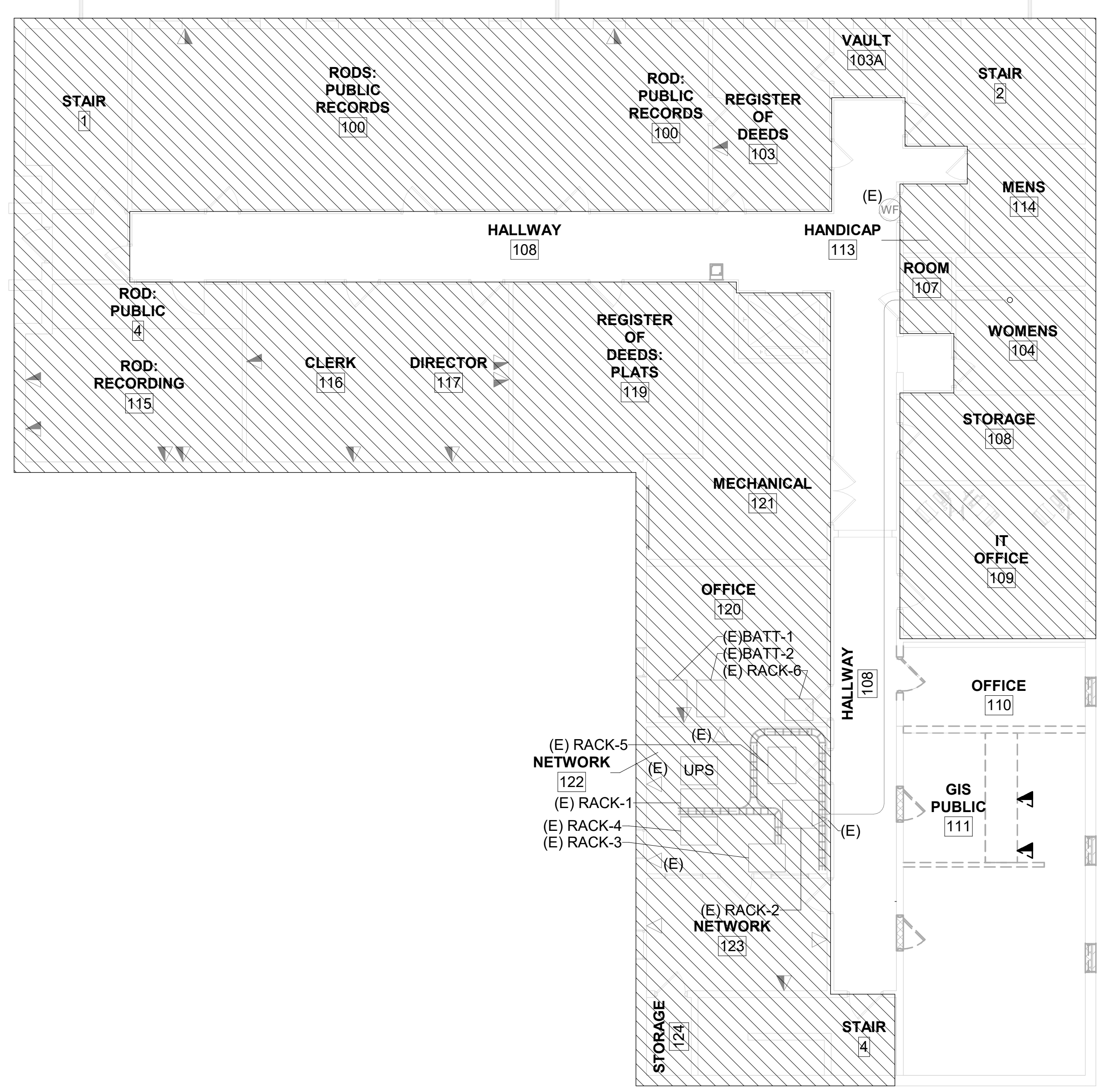

1 FIRST FLOOR TELECOMMUNICATION DEMOLITION PLAN - PHASE 2
E204 SCALE: 1/8" = 1'-0"

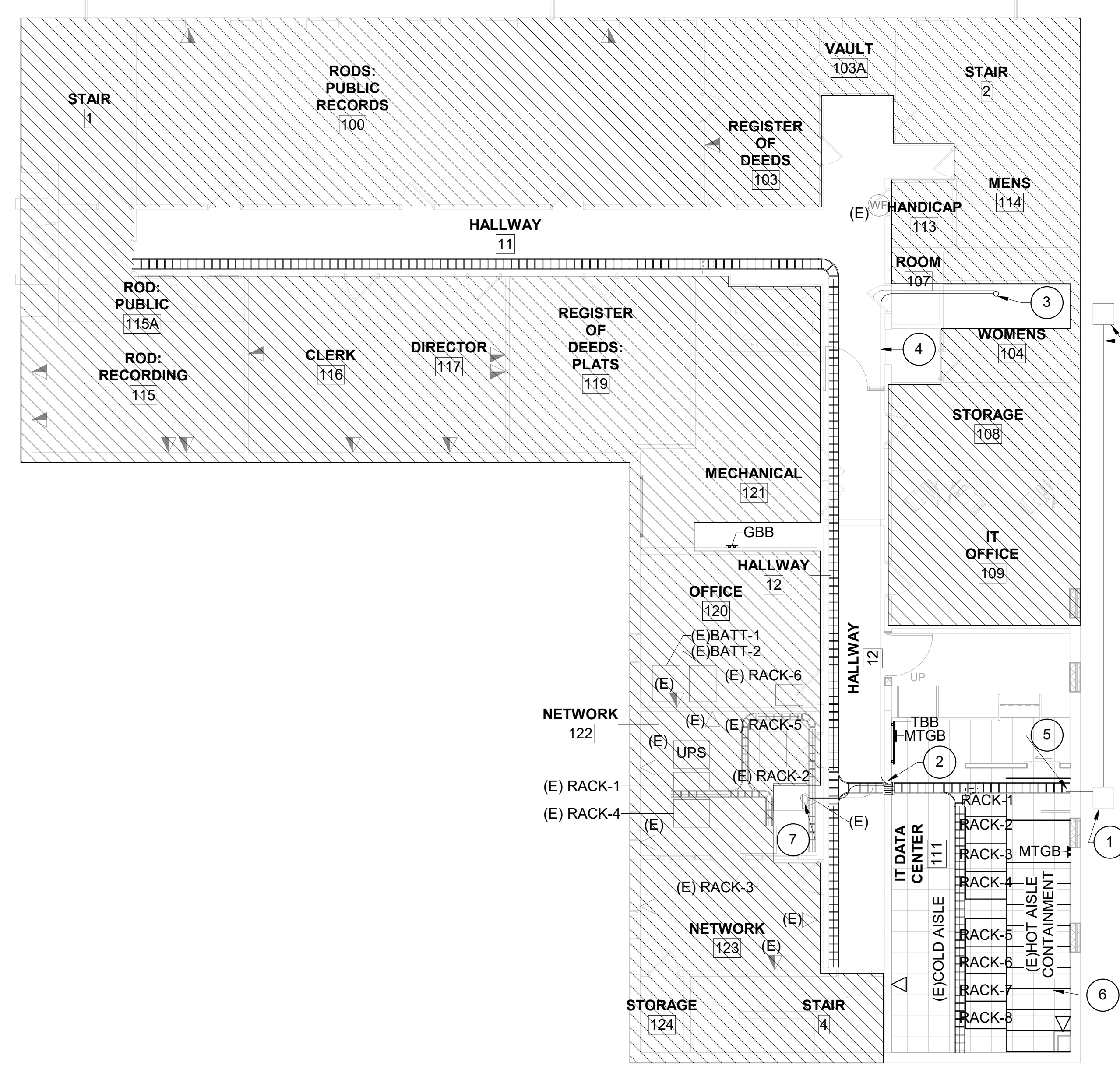

2 FIRST FLOOR TELECOMMUNICATION RENOVATION PLAN - PHASE 2
E204 SCALE: 1/8" = 1'-0"

| REV. | DATE | DESCRIPTION |
|------|------|-------------|
| | | |
| | | |
| | | |
| | | |

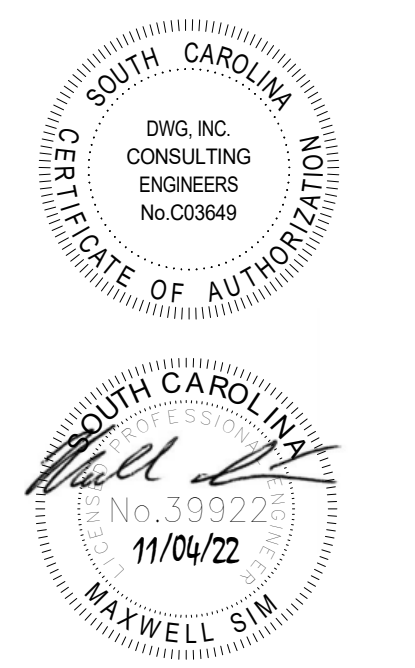

HARRELSON BUILDING IT DEPARTMENT RENOVATION
COLLETON COUNTY
31 KLEIN STREET,
WALTERBORO, SC 29488

COPYRIGHT © GLICKBOEHM & ASSOCIATES, INC.
JOB NUMBER: 19136-00
DRAWN BY: MHS
CHECKED BY: BSB
APPROVED BY: MHS
DATE ISSUED FOR: CONSTRUCTION DOCUMENTS 11/04/22

FIRST FLOOR TELECOM PLANS (PHASE 2)
E204

DEMOLITION KEYNOTES

- 1 UPS EQUIPMENT TO BE DISCONNECTED AND RELOCATED TO NEW IT ROOM AS SHOWN ON NEW PLAN. REMOVE ALL EXISTING INTERCONNECTIONS MAINTAINING CONNECTION POINTS FOR FUTURE RECONNECTION.
- 2 DEMOLISH RECEPTACLE. REMOVE CONDUIT AND WIRE BACK TO PANEL.
- 3 DISCONNECT AND REMOVE DUPLEX. CAP WIRING FOR INSTALLATION OF NEW DUPLEX RECEPTACLE.
- 4 DEMOLISH DISCONNECTS AND ALL CONDUIT AND WIRING TO SOURCE ASSOCIATED WITH CONDENSING UNIT TO BE DEMOLISHED. ANY EXTERIOR PENETRATIONS REMOVED SHALL BE SEALED TO MAINTAIN WALL RATING. FOLLOW MECHANICAL DRAWINGS PHASING FOR DEMOLITION OF UNITS.
- 5 REPLACE EXISTING BREAKER FEEDING DEMOLISHED HVAC EQUIPMENT WITH NEW 3 POLE 30A CIRCUIT BREAKER FOR NEW HEAT PUMP. CIRCUIT BREAKER SHALL BE COMPATIBLE WITH EXISTING ITE IMPERIAL TYPE NLAB PANELBOARD.

RENOVATION KEYNOTES

- 1 REPLACE EXISTING BREAKER FEEDING DEMOLISHED HVAC EQUIPMENT WITH NEW 3 POLE 30A CIRCUIT BREAKER FOR NEW HEAT PUMP. CIRCUIT BREAKER SHALL BE COMPATIBLE WITH EXISTING ITE IMPERIAL TYPE NLAB PANELBOARD.
- 2 INSTALL NEW DUPLEX RECEPTACLE IN EXISTING JUNCTION BOX AND WIRE TO EXISTING WIRING. PROVIDE NEW COVERPLATE.
- 3 PROVIDE 120V POWER FOR DOOR HARDWARE FROM NEAREST RECEPTACLE. COORDINATE INSTALLATION REQUIREMENTS WITH DOOR HARDWARE PROVIDER.
- 4

GENERAL NOTES

- 1. HATCHED REGION NOT IN PHASE 3 POWER SCOPE OF WORK.

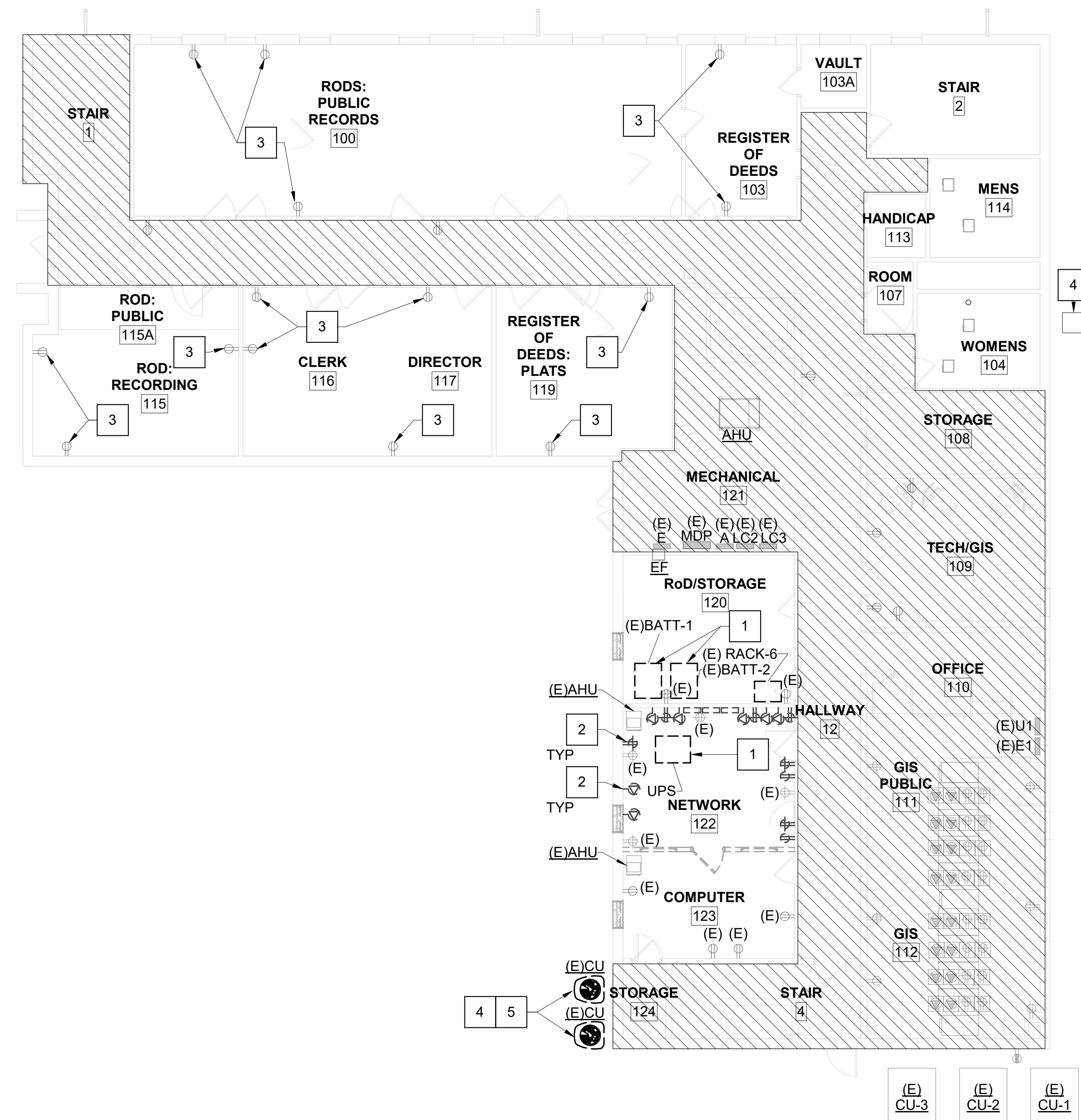

1 FIRST FLOOR POWER DEMOLITION PLAN - PHASE 3
E301 SCALE: 1/8" = 1'-0"

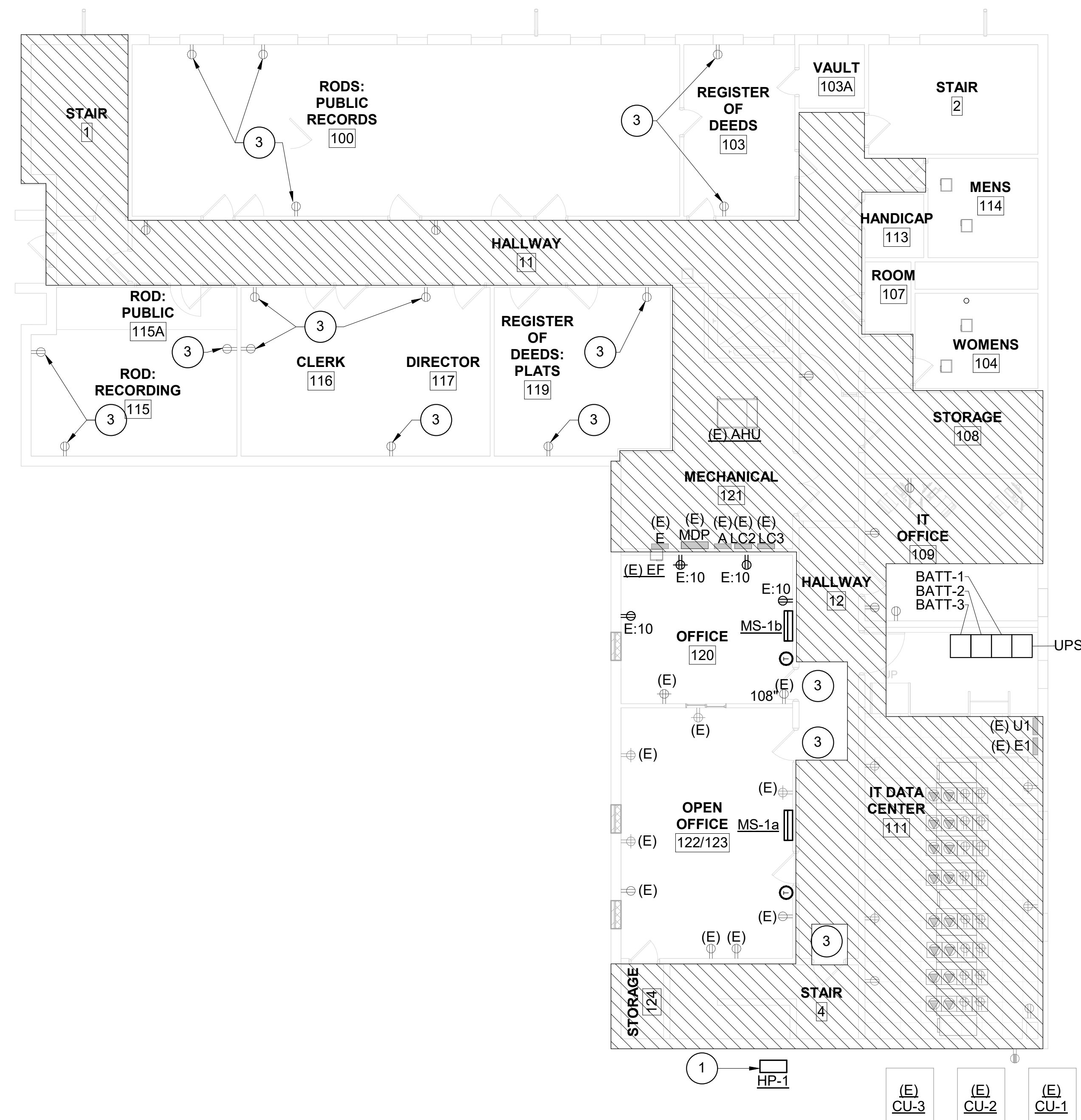

2 FIRST FLOOR POWER RENOVATION PLAN - PHASE 3
E301 SCALE: 1/8" = 1'-0"



| REV. | DATE | DESCRIPTION |
|------|------|-------------|
| | | |
| | | |
| | | |
| | | |

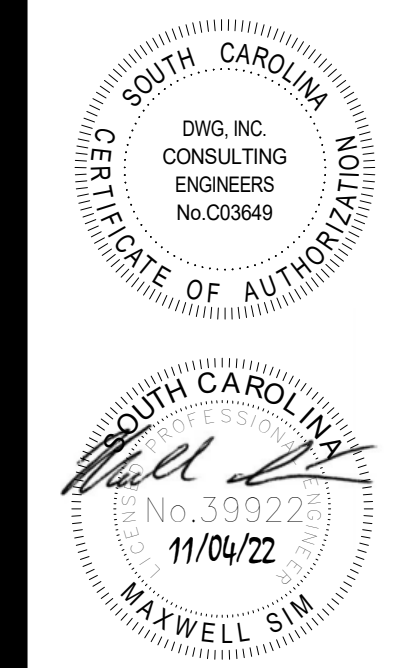

HARRELSON BUILDING IT DEPARTMENT RENOVATION
COLLETON COUNTY
31 KLEIN STREET,
WALTERBORO, SC 29488

COPYRIGHT © GLICK/BOEHM & ASSOCIATES, INC.
JOB NUMBER: 19136-00
DRAWN BY: MHS
CHECKED BY: BSB
APPROVED BY: MHS
DATE ISSUED FOR: CONSTRUCTION DOCUMENTS 11/04/22

FIRST FLOOR POWER PLAN (PHASE 3)

E301

DEMOLITION KEYNOTES

1 DEMOLISH LIGHT FIXTURE AND ASSOCIATED CONTROLS. REMOVE CONDUIT AND WIRE BACK TO NEAREST JUNCTION BOX.

RENOVATION KEYNOTES

1 CONNECT NEW LIGHT FIXTURE TO LIGHTING CIRCUIT MADE AVAILABLE DURING PHASE 3 DEMOLITION.

GENERAL NOTES

1. SHADED REGION NOT IN PHASE 3 LIGHTING SCOPE OF WORK.

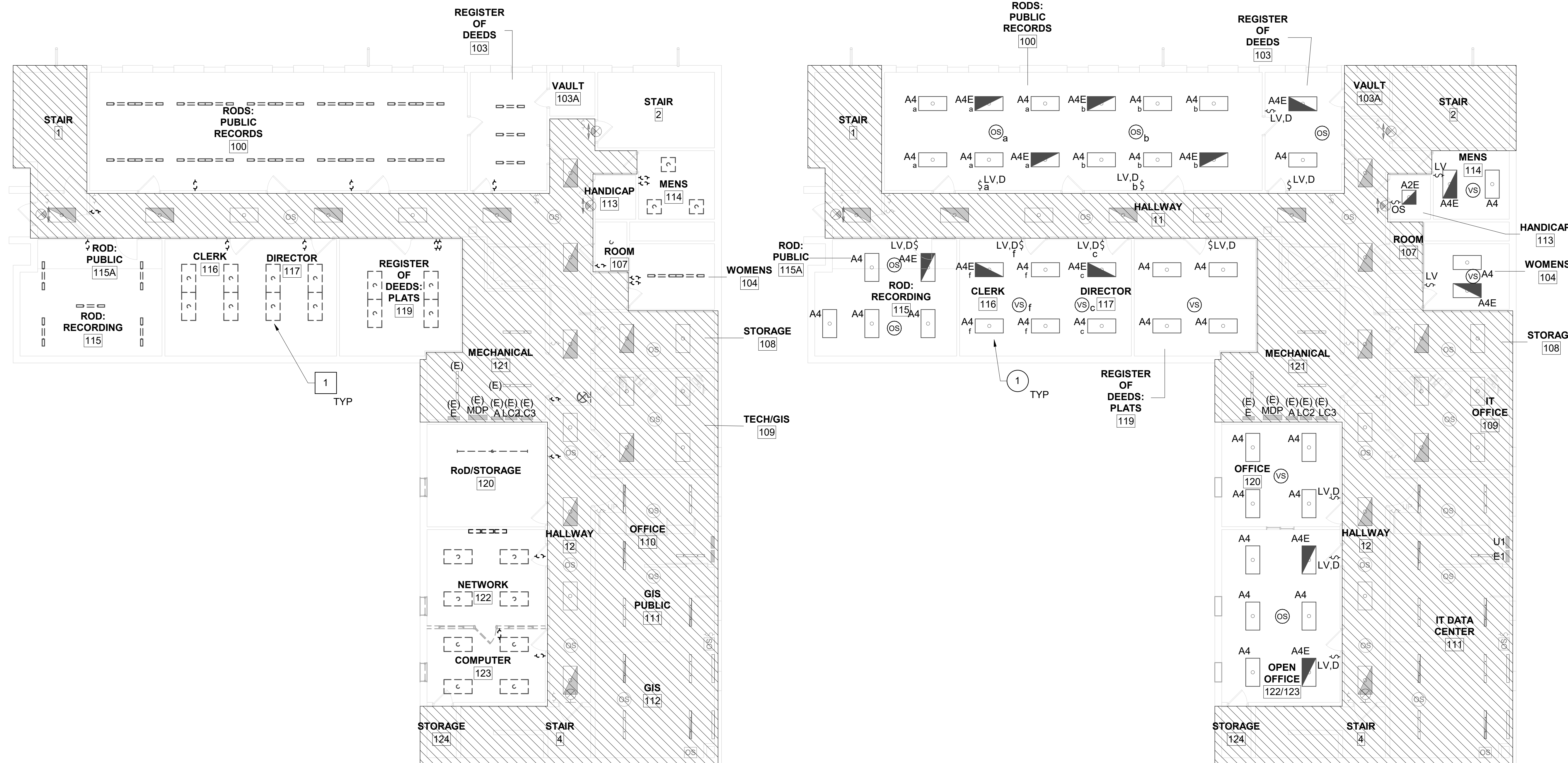
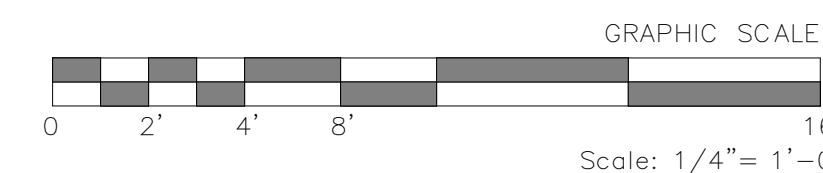

1 FIRST FLOOR LIGHTING DEMOLITION PLAN - PHASE 3
E302 SCALE: 1/8" = 1'-0"

2 FIRST FLOOR LIGHTING RENOVATION PLAN - PHASE 3
E302 SCALE: 1/8" = 1'-0"

| REV. | DATE | DESCRIPTION |
|------|------|-------------|
| | | |
| | | |
| | | |

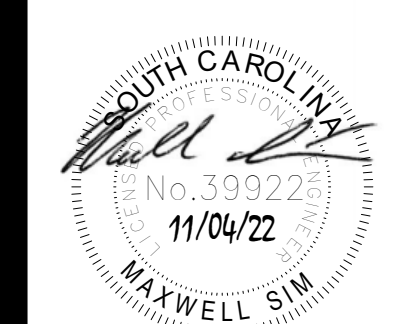

HARRELSON BUILDING IT DEPARTMENT RENOVATION
COLLETON COUNTY
31 KLEIN STREET,
WALTERBORO, SC 29488

COPYRIGHT © GLICK/BOEHM & ASSOCIATES, INC.
JOB NUMBER: 19136-00
DRAWN BY: MHS
CHECKED BY: BSB
APPROVED BY: MHS
DATE ISSUED FOR: CONSTRUCTION DOCUMENTS 11/04/22

FIRST FLOOR LIGHTING PLANS (PHASE 3)
E302

DEMOLITION KEYNOTES

- 1 EXISTING DEVICES IN CEILING SHALL BE TEMPORARILY REMOVED TO ALLOW CEILING REPLACEMENT, AND SHALL BE RE-INSTALLED IN NEW CEILING. HANDLE DEVICES WITH CARE, THEY SHALL BE RE-INSTALLED IN WORKING ORDER AND IN THE SAME CONDITION AS EXISTING. (TYPICAL)

GENERAL NOTES

- 1. ALL NEW FIRE ALARM DEVICES SHALL BE COMPATIBLE WITH EXISTING FIRE ALARM SYSTEM. NEW FIRE ALARM DEVICES SHALL BE TIED BACK INTO EXISTING FIRE ALARM SYSTEM. EXISTING FIRE ALARM CONTROL PANEL IS A FIRE-LITE MS-5UD.
- 2. SHADED REGION NOT IN PHASE 3 SYSTEMS SCOPE OF WORK.



GLICK BOEHM ARCHITECTURE
ARCHITECTURE PLANNING INTERIOR DESIGN
493 King Street, Suite 100 Charleston, South Carolina 29403
784.577.6377 www.glickboehm.com

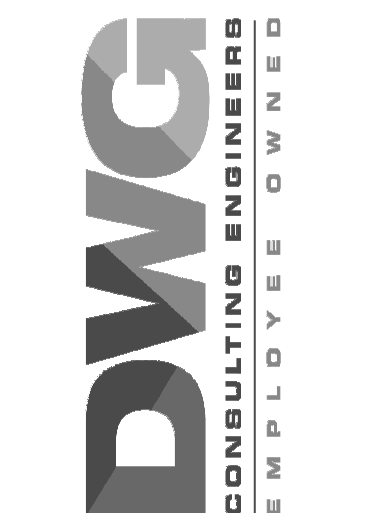

DWG CONSULTING ENGINEERS
EMPLOYEE OWNED

| REV. | DATE | DESCRIPTION |
|------|------|-------------|
| | | |
| | | |
| | | |
| | | |



HARRELSON BUILDING IT DEPARTMENT RENOVATION
COLLETON COUNTY
31 KLEIN STREET,
WALTERBORO, SC 29488

COPYRIGHT © GLICK/BOEHM & ASSOCIATES, INC.
JOB NUMBER: 19138-00
DRAWN BY: MHS
CHECKED BY: BSB
APPROVED BY: MHS
DATE ISSUED FOR: CONSTRUCTION DOCUMENTS 11/04/22

FIRST FLOOR SYSTEMS PLAN (PHASE 3)

E303

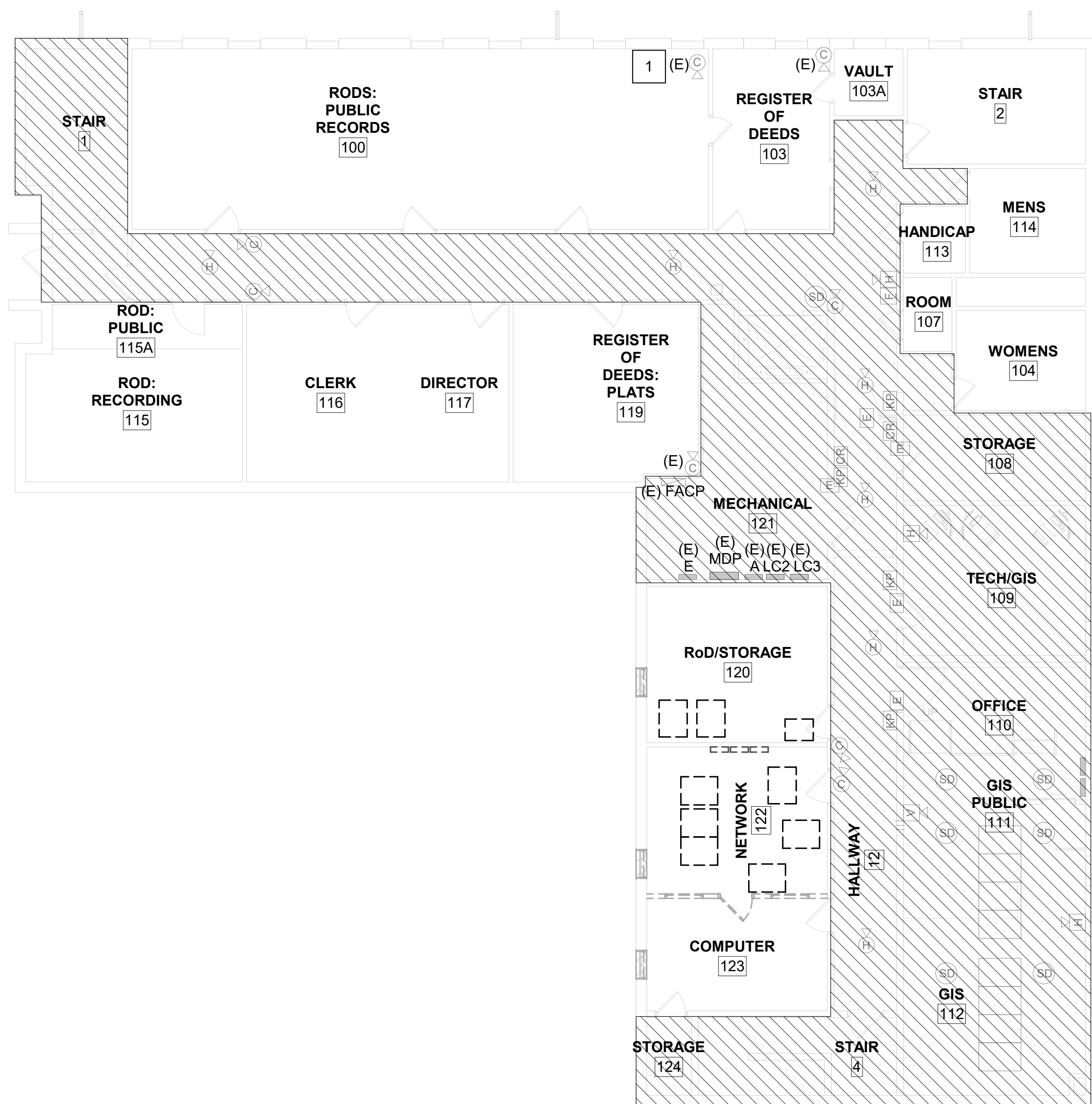

1 FIRST FLOOR SYSTEMS DEMOLITION PLAN - PHASE 3
E303 SCALE: 1/8" = 1'-0"

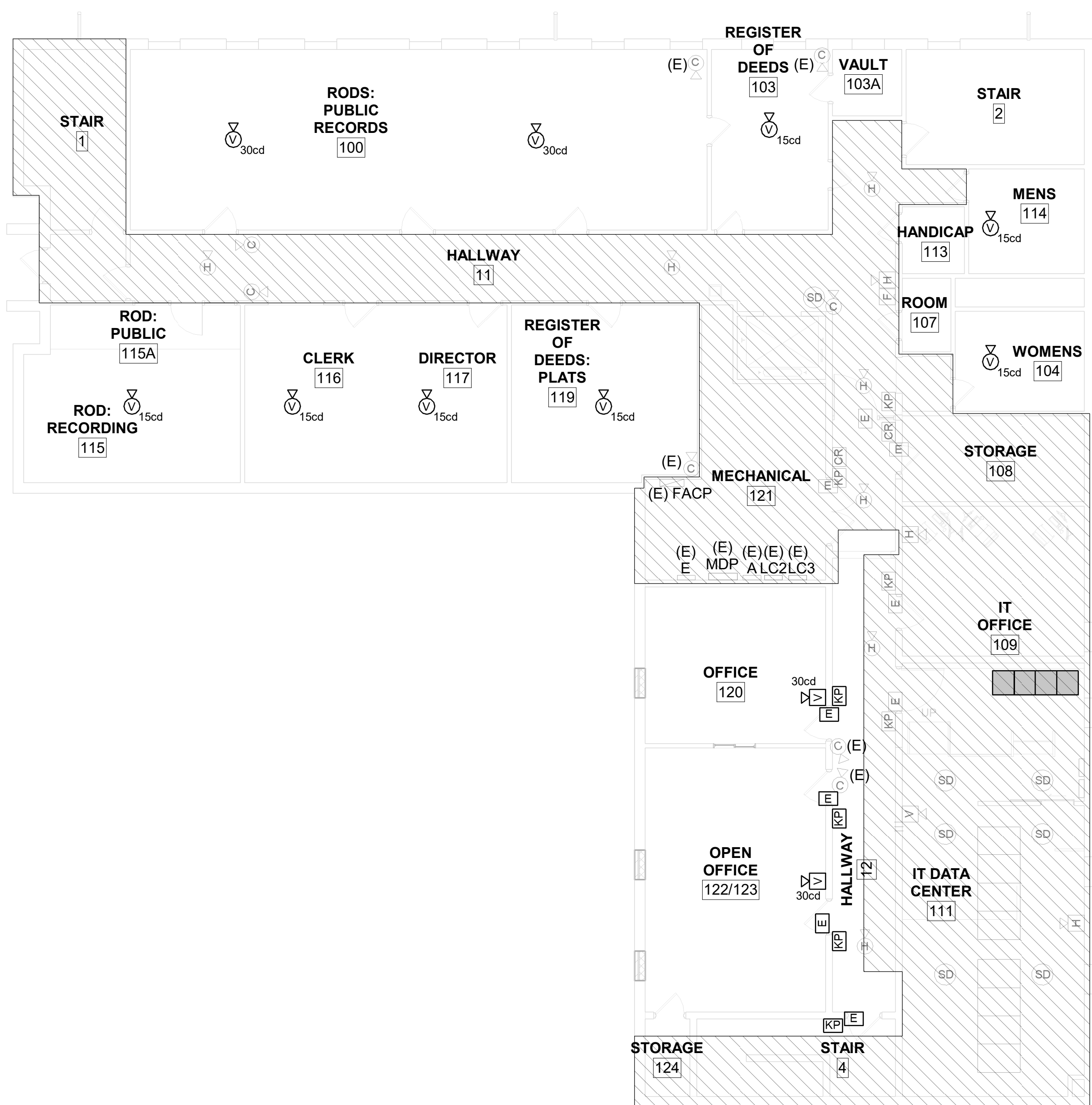

2 FIRST FLOOR SYSTEMS RENOVATION PLAN - PHASE 3
E303 SCALE: 1/8" = 1'-0"

DEMOLITION KEYNOTES

1 DATA RACKS TO BE REMOVED ONLY AFTER OWNER HAS CONFIRMED THAT THEY HAVE RELOCATED ALL EXISTING INTERNAL COMPONENTS INTO NEW DATA RACKS IN NEW IT.

RENOVATION KEYNOTES

1 DATA JACKS IN ROOM SHALL HAVE COVERPLATES REPLACED WITH NEW.

GENERAL NOTES

1. SHADED REGION NOT IN PHASE 3 TELECOM SCOPE OF WORK.

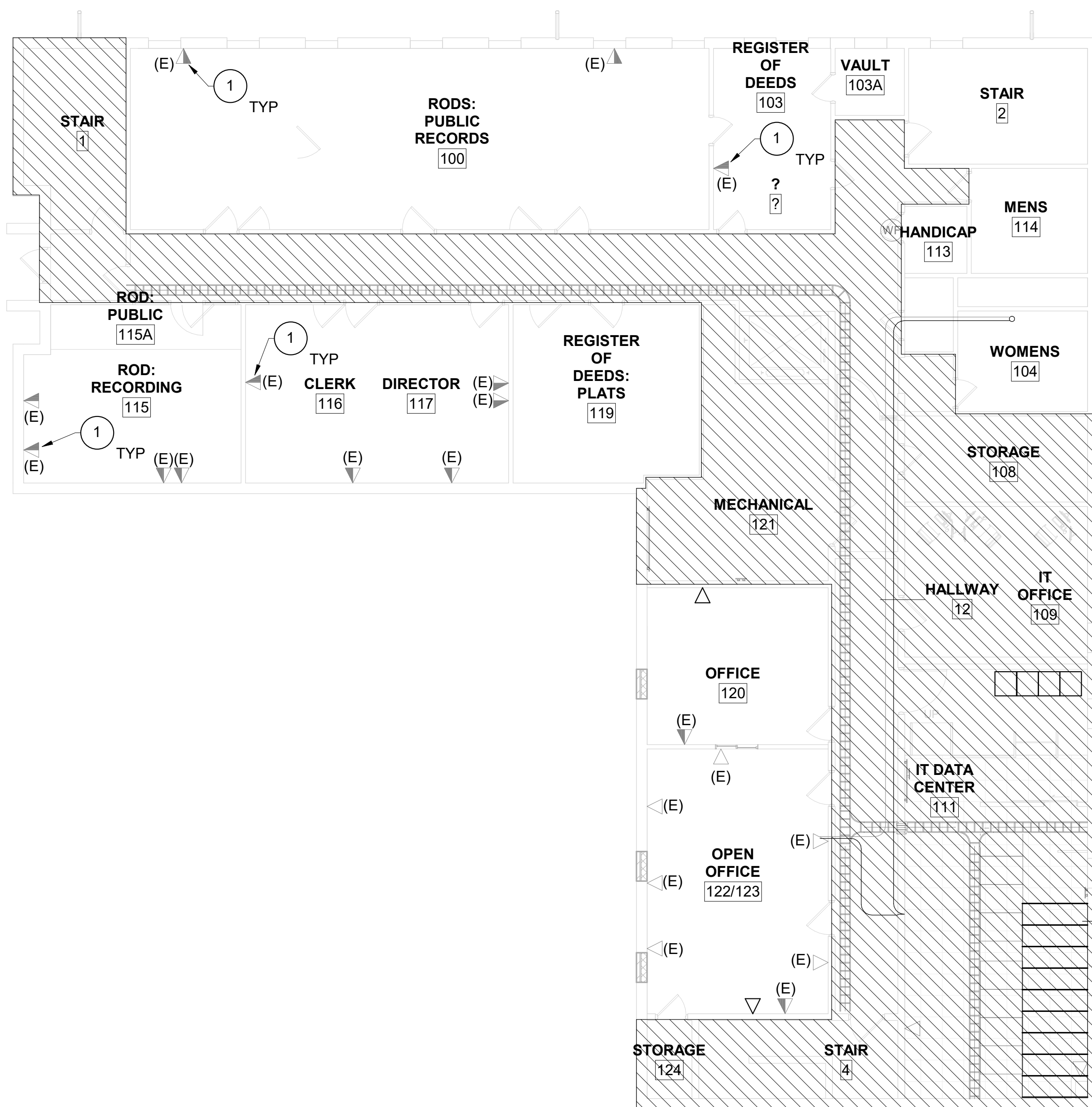
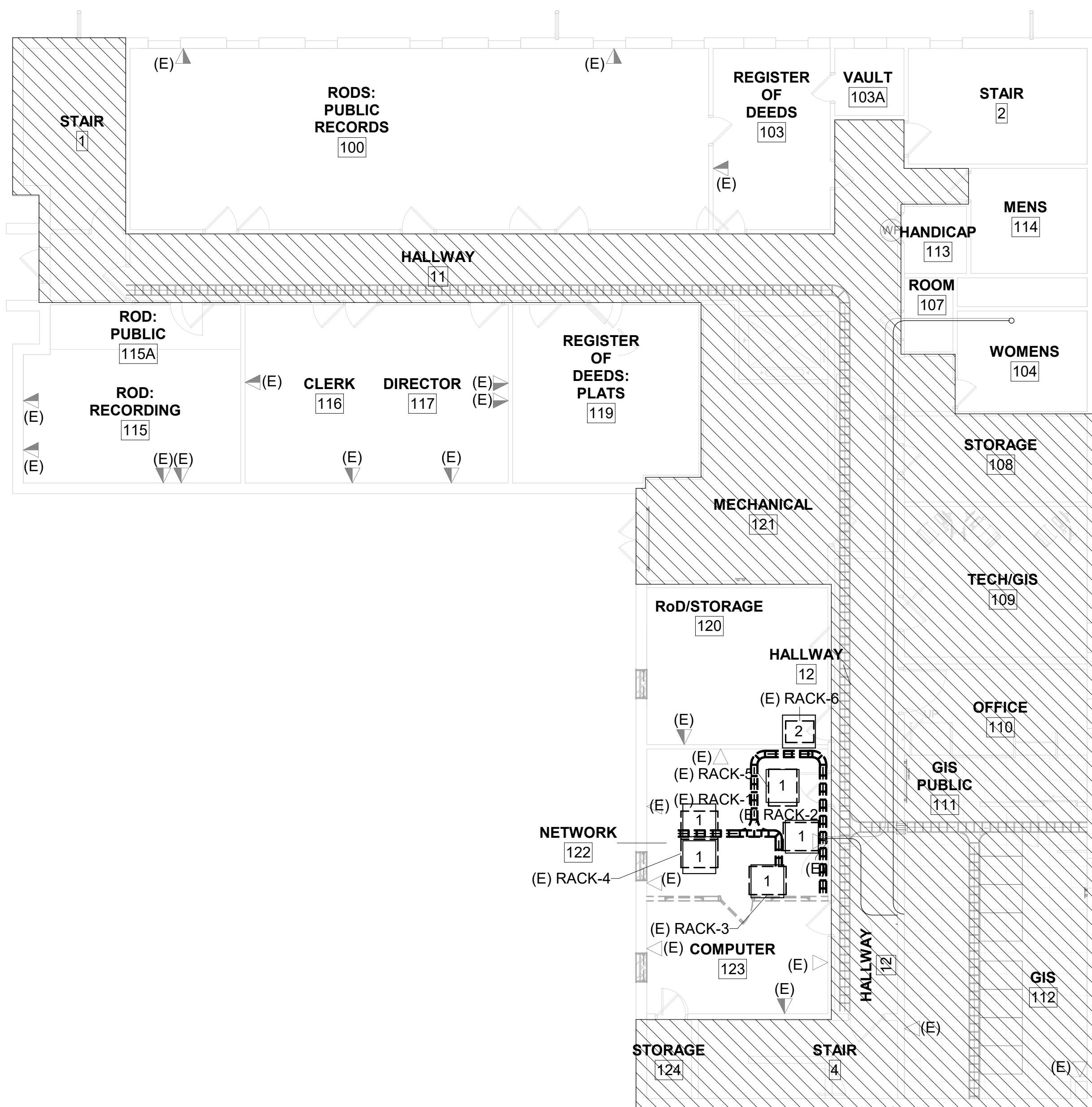

1 FIRST FLOOR TELECOMMUNICATION DEMOLITION PLAN - PHASE 3
E304 SCALE: 1/8" = 1'-0"

2 FIRST FLOOR TELECOMMUNICATION RENOVATION PLAN - PHASE 3
E304 SCALE: 1/8" = 1'-0"



GLICK BOEHM ARCHITECTURE
ARCHITECTURE PLANNING INTERIOR DESIGN
493 King Street, Suite 100 Charleston, South Carolina 29403
784.577.6377 www.glickboehm.com

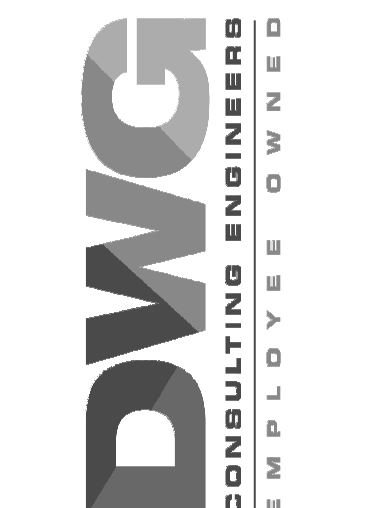

DWG CONSULTING ENGINEERS
EMPLOYEE OWNED

| REV. | DATE | DESCRIPTION |
|------|------|-------------|
| | | |
| | | |
| | | |
| | | |



HARRELSON BUILDING IT
DEPARTMENT
RENOVATION
COLLETON COUNTY
31 KLEIN STREET,
WALTERBORO, SC 29488

COPYRIGHT ©
GLICK/BOEHM & ASSOCIATES, INC.
JOB NUMBER: 19136-00
DRAWN BY: MHS
CHECKED BY: BSB
APPROVED BY: MHS
DATE ISSUED FOR:
CONSTRUCTION DOCUMENTS 11/04/22

FIRST FLOOR
TELECOM PLAN
(PHASE 3)

E304

SPECIFICATIONS

HARRELSON BUILDING IT DEPARTMENT RENOVATION

31 Klein Street
Walterboro, SC 29488

For The Owner:

Colleton County

GBA PROJECT No.: 1924

DATE: 11/04/2022

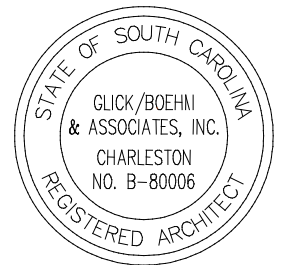
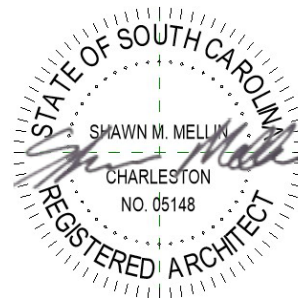

ARCHITECTURE / PLANNING / INTERIOR DESIGN

GLICK/BOEHM & ASSOCIATES, INC.

493 King Street, Suite 100

Charleston, South Carolina 29403

Telephone: 843.577.6377

Fax: 722.1768

Internet: www.GBAarchitecture.com

DOCUMENT 00 01 05

PROJECT DIRECTORY

PROJECT: **Harrelson Building**
IT Department Renovation
31 Klein Street
Walterboro, SC 29488

OWNER: **Colleton County**

ARCHITECT: **Glick/Boehm & Associates, Inc.**
493 King Street, Suite 100
Charleston, SC 29403
843-577-6377

MECHANICAL/ELECTRICAL/
CONSULTANT: **DWG Consulting Engineers, Inc.**
1009 Anna Knapp Blvd., Suite 202
Mount Pleasant, SC 29464
843-849-1141

END OF PROJECT DIRECTORY

SECTION 00 01 10
TABLE OF CONTENTS

DIVISION 00 - INTRODUCTORY INFORMATION, BIDDING REQUIREMENTS, AND CONTRACT REQUIREMENTS

- 00 01 05 – PROJECT DIRECTORY
- 00 01 10 – TABLE OF CONTENTS
- 00 31 00 – AVAILABLE PROJECT INFORMATION

DIVISION 01 - GENERAL REQUIREMENTS

- 01 32 16 – CONSTRUCTION PROGRESS SCHEDULE

DIVISION 02 - SITE CONSTRUCTION

- 02 41 00 – DEMOLITION

DIVISION 03 – CONCRETE

NOT USED

DIVISION 04 - MASONRY

NOT USED

DIVISION 05 - METALS

NOT USED

DIVISION 06 - WOOD AND PLASTICS

- 06 10 00 – ROUGH CARPENTRY
- 06 20 00 – FINISH CARPENTRY

DIVISION 07 - THERMAL AND MOISTURE PROTECTION

- 07 84 00 – FIRESTOPPING
- 07 90 05 – JOINT SEALERS

DIVISION 08 - DOORS AND WINDOWS

- 08 11 13 – HOLLOW METAL FRAMES
- 08 14 16 – FLUSH WOOD DOORS
- 08 71 00 – DOOR HARDWARE
- 08 43 13 – ALUMINUM-FRAMED STOREFRONTS
- 08 80 00 - GLAZING

DIVISION 09 - FINISHES

- 09 21 16 – GYPSUM BOARD ASSEMBLIES
- 09 51 00 – ACOUSTICAL CEILINGS
- 09 65 00 – RESILIENT FLOORING
- 09 68 00 – CARPETING
- 09 90 00 – PAINTING AND COATING

DIVISION 10 - SPECIALTIES

NOT USED

DIVISION 11 - EQUIPMENT

NOT USED

DIVISION 12 - FURNISHINGS

NOT USED

DIVISION 13 – SPECIAL CONSTRUCTION

NOT USED

DIVISION 14 – VERTICAL CIRCULATION

NOT USED

DIVISION 21 – FIRE SUPPRESSION

NOT USED

DIVISION 22 – PLUMBING

NOT USED

DIVISION 23 – HEATING, VENTILATING AND AIR CONDITIONING

- 23 00 00 – BASIC MECHANICAL MATERIALS AND METHODS
- 23 05 10 – MECHANICAL COORDINATION
- 23 05 29 – HANGERS AND SUPPORTS FOR HVAC PIPING AND EQUIPMENT
- 23 05 48 – VIBRATION AND SEISMIC CONTROLS FOR HVAC
- 23 05 53 – IDENTIFICATION FOR HVAC PIPING AND EQUIPMENT
- 23 05 93 – TESTING, ADJUSTING AND BALANCING FOR HVAC
- 23 07 13 – DUCT INSULATION
- 23 07 19 – HVAC PIPING INSTALLATION
- 23 23 00 -- REFRIGERANT PIPING
- 23 31 13 – METAL DUCTS
- 23 33 00 – AIR DUCT ACCESSORIES
- 23 37 13 – DIFFUSERS, REISTERS AND GRILLES
- 23 81 23 – COMPUTER-ROOM AIR-CONDITIONER
- 23 81 26 – SPLIT-SYSTEM AIR CONDITIONER

DIVISION 26 – ELECTRICAL

- 26 05 00 – COMMON WORK RESULTS FOR ELECTRICAL
- 26 05 01 – ELECTRICAL DEMOLITION
- 26 05 10 – ELECTRICAL SUBMITTALS
- 26 05 11 – ELECTRICAL WORK CLOSEOUT
- 26 05 12 – ELECTRICAL COORDINATION
- 26 05 19 – LOW-VOLTAGE ELECTRICAL CONDUCTORS AND CABLES
- 26 05 26 – GROUNDING AND BONDING FOR ELECTRICAL SYSTEMS
- 26 05 29 – HANGERS AND SUPPORTS FOR ELECTRICAL SYSTEMS
- 26 05 33 – RACEWAY AND BOXES FOR ELECTRICAL SYSTEMS
- 26 05 36 – CABLE TRAYS FOR ELECTRICAL SYSTEMS
- 26 05 48 – VIBRATION AND SEISMIC CONTROLS FOR ELECTRICAL SYSTEMS
- 26 05 53 – IDENTIFICATION FOR ELECTRICAL SYSTEMS
- 26 24 00 – PANELBOARDS
- 26 27 26 – WIRING DEVICES
- 26 28 16 – ENCLOSED SWITCHES AND CIRCUIT BREAKERS
- 26 43 00 – SURGE PROTECTIVE DEVICES
- 26 51 00 – LIGHTING

DIVISION 27 – COMMUNICATIONS

- 27 05 00 – COMMON WORK RESULTS FOR COMMUNICATIONS
- 27 11 01 – COMMUNICATION EQUIPMENT RACKS
- 27 13 00 – COMMUNICATIONS BACKBONE CABLE

DIVISION 28 – ELECTRONIC SAFETY AND SECURITY

- 28 05 00 – COMMON WORK RESULTS FOR SAFETY AND SECURITY
- 28 10 00 – ACCESS CONTROL REQUIREMENTS
- 28 31 01 – FIRE DETECTION ALARM

SECTION 00 31 00
AVAILABLE PROJECT INFORMATION

PART 1 GENERAL

1.01 EXISTING CONDITIONS

- A. Limited Asbestos Assessment Update Report: The report prepared by S&ME is titled Limited Asbestos Assessment Update Report, Colleton County Office Building, 31 Klein Street, Walterboro, South Carolina, S&ME Project No 4213-20-165 dated 7-6-2020.

PART 2 PRODUCTS (NOT USED)

PART 3 EXECUTION (NOT USED)

END OF SECTION



**Limited Asbestos Assessment Update Report
Colleton County Office Building
31 Klein Street
Walterboro, South Carolina
S&ME Project No. 4213-20-165**

Assessment Performed by and Report Prepared by:

A blue ink signature of William R. Seaborn.

7-6-2020

William R. Seaborn (SCDHEC Accreditation #BI-01317) Date

PREPARED FOR:

**GBA Architecture
493 King Street, Suite 100
Charleston, South Carolina 29403**

PREPARED BY:

**S&ME, Inc.
620 Wando Park Boulevard
Mt Pleasant, SC 29464**

July 6, 2020



Table of Contents

| | |
|--|----------|
| Executive Summary | 1 |
| 1.0 Background | 3 |
| 2.0 Site and Project Description | 3 |
| 2.1 Purpose | 3 |
| 2.2 Site Description | 3 |
| 3.0 Asbestos Assessment..... | 3 |
| 3.1 Procedures | 3 |
| 3.2 Findings and Results | 4 |
| 4.0 Conclusions and Recommendations | 5 |
| 5.0 Assumptions and Limitations | 5 |

Appendices

Appendix I – Summary of Asbestos Results

Appendix II – Diagram of Bulk Sample Locations and Confirmed ACMs

Appendix III - Copy of Inspector’s SCDHEC Licenses

Appendix IV – Laboratory Analysis Sheets and Chain of Custody Records

Appendix V – Copy of the 2015 Limited Asbestos and Lead-Based Paint Assessment



Executive Summary

An asbestos assessment update was conducted on June 25, 2020, limited to the areas of planned renovation at the Colleton County Office Building located at 31 Klein Street in Walterboro, South Carolina. This assessment update was requested to support planned interior renovations in the facility. This assessment updates and supplements the *Limited Asbestos and Lead-Based Paint Assessment (Project No. 4213-15-257)*, by S&ME Inc., dated November 19, 2015 which is included in Appendix V and should be used in conjunction with this report. The purpose of the assessment was to update the referenced report and identify and assess asbestos containing materials (ACMs) associated with the planned interior renovations. The assessment also complies with federal, state, and local asbestos requirements regarding identification of ACMs that may be disturbed due to renovation or demolition.

The Colleton County Service Building is a three-story building, approximately 21,000 square feet in size. The building is constructed of steel framing with exterior brick veneer and a flat built-up roof. Interior finishes include drywall walls and a suspended ceiling system with acoustical ceiling tiles. The flooring consisted of terrazzo, vinyl floor tile and carpeting. The facility was occupied and in operation on the day of our site visit.

Based on the 2015 assessment, and a confirmatory sample collected and analyzed for the limited assessment update performed on June 25, 2020, vinyl floor tile and associated mastic, and mastic on the HVAC ductwork were identified as ACM as noted in the following table (Table I).

Table I: Summary of Confirmed ACMs

| Material | HA | Location | Asbestos Type | Percent | Condition | Potential for Disturbance | *Approx. Quantity |
|---|------------|----------------|---------------|---------|-----------|---------------------------|-------------------|
| Vinyl Floor Tile (12" grey) and associated Mastic (Black) | FT and FT2 | Storage room | Chrysotile | 3 6 | G, NF | PSD | 320 SF |
| Mastic (grey) associated with HVAC ductwork | DM | Above ceilings | Chrysotile | 6 | G, NF | PSD | 2,880 SF |

*Note: The quantities are estimated and should be field verified for bidding purposes.

Abbreviations:

HA = homogeneous area SF = square feet LF = linear feet
 G = good D = damaged NF = non-friable F = friable
 LPD = low potential for disturbance PD = potential for disturbance PSD = potential for sig. disturbance

The identified vinyl floor tile and associated mastic as well as the mastic (grey) associated with heating, ventilation and air conditioning (HVAC) ductwork are classified as Category I non-friable ACMs, in good condition, with a potential for significant disturbance due to the planned renovation actions.



We recommend proper removal and disposal of the identified ACMs by a SCDHEC licensed asbestos abatement contractor, as required by the EPA and SCDHEC, prior to any disturbance. The SCDHEC requires onsite asbestos air monitoring, by a SCDHEC licensed Air Sampler, prior to, during, and following abatement of friable ACMs, or non-friable ACMs rendered friable, and totaling 160 square feet or greater. If additional suspect materials that are not addressed in this report will be disturbed as part of the planned renovation activities, bulk samples must be collected by a SCDHEC licensed inspector, prior to continuation of the work or disturbance and disposal of the material. This report should also be provided to the contractors working in the subject areas to assist with compliance with applicable regulations.



1.0 Background

S&ME, Inc. (S&ME) was contracted by GBA Architecture to perform an asbestos assessment update, limited to the areas of planned renovation at the Colleton County Office Building located at 31 Klein Street in Walterboro, South Carolina. The purpose of the assessment was to update the existing *Limited Asbestos and Lead-Based Paint Assessment (Project No. 4213-15-257)*, by S&ME Inc., dated November 19, 2015, perform supplemental sampling to meet state and local asbestos requirements, and identify the presence of asbestos containing materials (ACMs) associated with the planned interior renovation. The assessment update also complies with federal, state, and local asbestos requirements regarding identification of ACMs that may be disturbed due to renovation or demolition.

The asbestos assessment was conducted to assess and identify ACMs in accordance with regulatory requirements. The identification of ACMs will aid in the prevention of occupational exposures and/or environmental releases of airborne asbestos. Identification of ACMs also complies with Title 40 Code of the Federal Regulations, part 61, and State regulation 61-86.1 enforced by the South Carolina Department of Health and Environmental Control (SCDHEC), along with Title 29 Code of Federal Regulations, part 1926 enforced by the Occupational Safety and Health Administration (OSHA). The following sections describe the assessment procedures used, results, and analyzed, and conclusions and recommendations related to ACMs.

2.0 Site and Project Description

2.1 Purpose

The purpose of the assessment was to identify the presence of ACMs prior to destructive activities associated with the planned interior renovation. This work was limited to select areas of the interior based on provided drawings by GBA Architecture. An assessment strategy appropriate for this purpose was presented in our proposal and is described in this report. The report should be interpreted only with regard to the specific location and materials referenced.

2.2 Site Description

The Colleton County Service Building is a three-story building, approximately 21,000 square feet in size. The building is constructed of steel framing with exterior brick veneer and a flat built-up roof. Interior finishes include drywall walls and suspended acoustical ceiling tiles. The flooring consisted of terrazzo, vinyl floor tile and carpeting. The facility was occupied and in operation on the day of our site visit.

3.0 Asbestos Assessment

3.1 Procedures

The assessment was performed by reviewing the 2015 *Limited Asbestos and Lead-Based Paint Assessment*, prepared by S&ME. Following the report review, the facility was visually assessed for those previously identified



ACMs and collection of a confirmatory sample to address applicable state and federal asbestos requirements. The possibility exists that suspect materials were undetected in inaccessible areas such as wall voids or areas covered by soil or concrete. If additional suspect ACMs not identified in this report are discovered during the planned destructive activities, bulk samples must be collected by a SCDHEC licensed inspector and analyzed for asbestos content prior to disturbance or disposal of the suspect materials.

The visual assessment and collection of a confirmatory was conducted by a SCDHEC licensed asbestos inspector. The confirmatory bulk sample extracted was recorded on a chain of custody record and submitted to our in-house laboratory for analysis by Polarized Light Microscopy (PLM). The laboratory is located in Charlotte, North Carolina and is accredited by the National Voluntary Laboratory Accreditation Program (NVLAP), which is administered by the National Institute of Standards and Technology.

The confirmatory sample was analyzed by trained microscopists using PLM techniques coupled with dispersion staining in accordance with the Environmental Protection Agency (EPA) Test Method Title 40 Code of Federal Regulations, Chapter I (1-1-87 edition), Part 763, Subpart F-APPENDIX A. This method identifies asbestos mineral fibers based on six optical characteristics: morphology, birefringence, refractive index, extinction angle, sign of elongation and dispersion staining colors. The laboratory analysis reports the specific type of asbestos identified (there are six asbestos minerals) and the percentage of asbestos present.

ACMs were categorized based on the EPA's NESHAP regulation categories. A friable ACM is classified as an ACM that can be crumbled to a powder by moderate hand pressure. A non-friable ACM is classified as either Category I or Category II non-friable ACM. Category I and Category II non-friable ACMs are distinguished from each other by their fiber release potential when damaged. Generally, Category I non-friable ACM, which by definition includes intact asbestos-containing roofing materials, gaskets, packing, and resilient floor coverings, is less likely to become friable and release fibers in a damaged state. Category II non-friable ACM include all other non-friable ACMs excluding Category I that have a high probability of being rendered friable during removal activities or demolition. All friable ACM, Category I non-friable ACM that has become friable, Category I non-friable ACM that will be or has been subjected to sanding, grinding, cutting or abrading, or Category II non-friable ACM that has a high probability of becoming or has become crumbled, pulverized, or reduced to powder by the forces expected to act on the material in the course of demolition or renovation operations are considered to be a Regulated Asbestos-Containing Material (RACM).

3.2 Findings and Results

The ACMs previously identified and confirmed as part of the limited assessment update performed on June 25, 2020, included vinyl floor tile and associated mastic, and mastic on overhead HVAC ducting. The ACMs identified are summarized in the following table (Table I).



Table I: Summary of Confirmed ACMs

| Material | HA | Location | Asbestos Type | Percent | Condition | Potential for Disturbance | *Approx. Quantity |
|---|------------|----------------|---------------|---------|-----------|---------------------------|-------------------|
| Vinyl Floor Tile (12" grey) and associated Mastic (Black) | FT and FT2 | Storage room | Chrysotile | 3 6 | G, NF | PSD | 320 SF |
| Mastic (grey) associated with HVAC ductwork | DM | Above ceilings | Chrysotile | 6 | G, NF | PSD | 2 ,880 SF |

*Note: The quantities are estimated and should be field verified for bidding purposes.

Abbreviations:

HA = homogeneous area SF = square feet LF = linear feet
 G = good D = damaged NF = non-friable F = friable
 LPD = low potential for disturbance PD = potential for disturbance PSD = potential for sig. disturbance

The identified vinyl floor tile and associated mastic as well as the mastic (grey) associated with HVAC ductwork are classified as Category I non-friable ACMs, in good condition, also with a potential for significant disturbance.

The EPA, SCDHEC, and OSHA defines a material as an ACM if an asbestos content greater than one percent (>1%) is detected in a representative sample.

A summary of asbestos results is provided in Appendix I, and exhibits the sample number, location, type of material tested, approximate quantity of the material sampled, condition of the material, and corresponding result for the collected confirmatory sample. A diagram of areas included in the assessment, the bulk sample location, and confirmed ACMs is provided in Appendix II. A copy of the inspector’s SCDHEC license is provided in Appendix III. The laboratory analyses and chain-of-custody record is provided in Appendix IV.

4.0 Conclusions and Recommendations

The limited asbestos assessment update performed on June 25, 2020, limited to the areas of planned renovation at the Colleton County Office Building located at 31 Klein Street in Walterboro, South Carolina, identified the presence of ACMs.

We recommend proper removal and disposal of the identified ACMs by a SCDHEC licensed asbestos abatement contractor, as required by the EPA and SCDHEC, prior to any disturbance. The SCDHEC requires onsite asbestos air monitoring, by a SCDHEC licensed Air Sampler, prior to, during, and following abatement of friable ACMs, or non-friable ACMs rendered friable, and totaling 160 square feet or greater. If additional suspect materials that are not addressed in this report will be disturbed as part of the planned renovation activities, bulk samples must be collected by a SCDHEC licensed inspector, prior to continuation of the work or disturbance and disposal of the



material. This report should also be provided to the contractors working in the subject areas to assist with compliance with applicable regulations.

5.0 Assumptions and Limitations

This report is provided for the sole use of GBA Architecture, Colleton County and their assignees. Use of this report by any other parties will be at such party's sole risk, and S&ME disclaims liability for any such use or reliance by third parties. The results presented in this report are indicative of conditions only during the time of the sampling period and of the specific areas referenced. Under no circumstances is this report to be used as a bidding document, or as a project design or specification for the abatement of hazardous materials.

S&ME performed the services in accordance with generally accepted practices of reputable environmental consultants undertaking similar studies at the same time and in the same geographical area. S&ME has endeavored to meet this standard of care. No other warranty, expressed or implied, is intended or made with respect to this report or S&ME's services. Users of this report should consider the scope and limitations related to these services when developing opinions as to risks associated with the site.

The assessment was limited to the area of planned interior renovation. The findings of the asbestos assessment update were based largely on visual observations. The findings do not warrant that all asbestos containing materials have been identified; ACMs could be present in areas not readily-accessible to observation. In addition, the actual locations and quantities of materials determined to contain asbestos may vary from those herein. Apparent homogeneous sampling areas may vary in actual asbestos content due to previous renovations, maintenance or related operations. The possibility exists that suspect materials were undetected in inaccessible or concealed areas such as under soils and inside pipe chases or wall voids. If additional suspect materials are discovered during the planned destructive activities, bulk samples should be collected by an asbestos inspector and analyzed for asbestos content.

Appendices

Appendix I – Summary of Asbestos Results



Table I: Summary of Asbestos Results

| HA | Material Description | Material Location | ² Approx. Quantity | Cat. (F/I/II) | Type | Condition/ Potential for Disturbance | Sample Number | Sample Location | ¹ Type and Percent Asbestos |
|----|---|-------------------|-------------------------------|---------------|-------|---|---------------|-----------------|--|
| FT | Vinyl Floor Tile (12" grey) Mastic (black) | Storage Room | 160 SF | NF Cat I | Misc. | N/A | 165-FT-01 | Storage Room | 3 6 |

LF = linear feet

F= friable

NF = non-friable

Cat I = Category I

Cat II = Category II

Sur = Surfacing

TSI = Thermal System Insulation

G = good

D = damaged

SD = significantly damaged

Misc. = Miscellaneous

PD = potential for disturbance

PSD = potential for significant disturbance

ND = No Asbestos Detected

N/A = Not Applicable

EA = each

Bold = > 1% Asbestos

¹EPA, SCDHEC and OSHA defines a material as asbestos containing if an asbestos content greater than one percent (>1%) is detected in a representative sample

²Quantities are estimated, and should not be used for bidding purposes, as field conditions should be verified

³Samples analyzed by TEM to confirm negative results reported by PLM analysis

**Appendix II – Diagram of Bulk Sample Locations and Confirmed
ACMs**

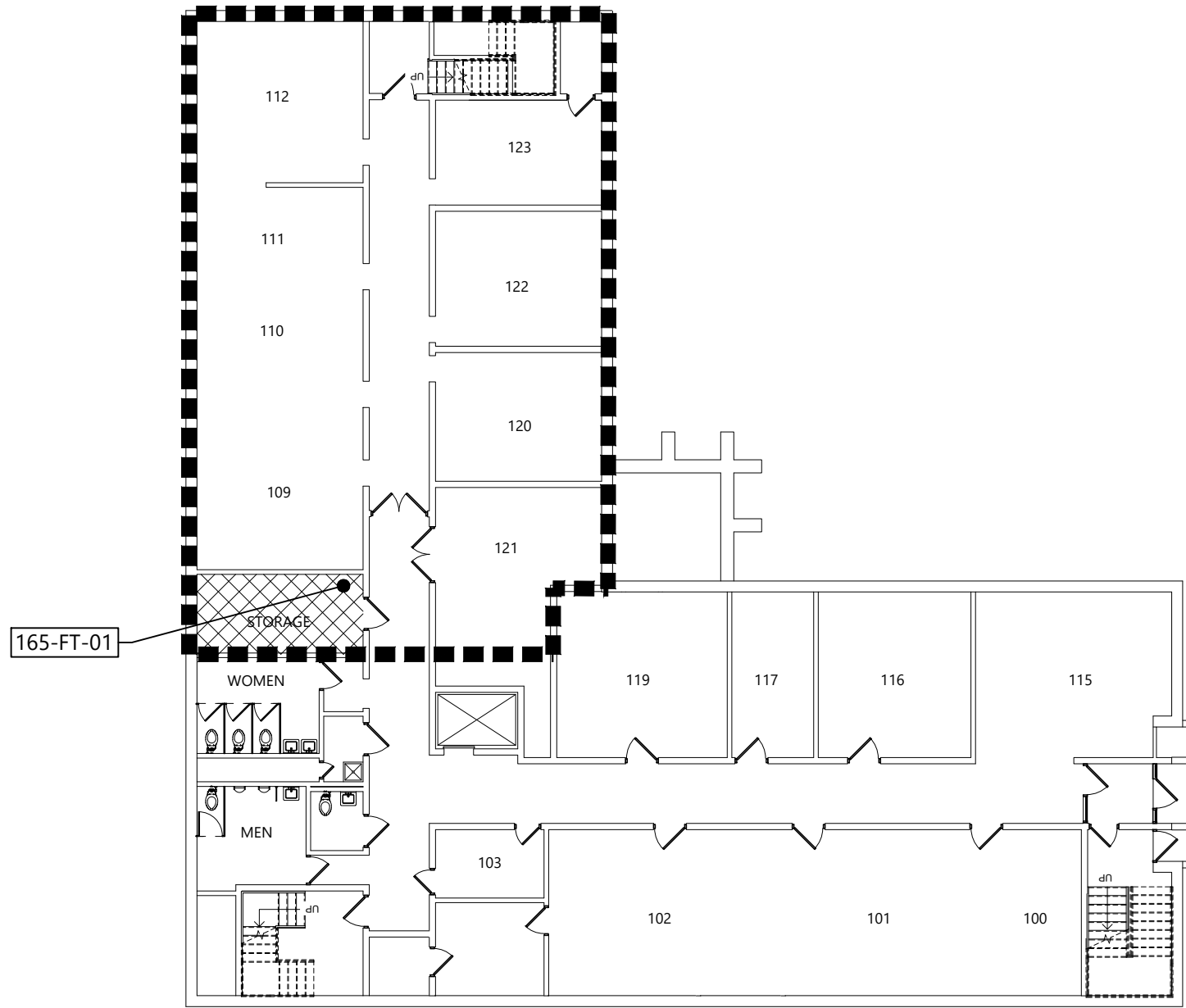

LEGEND

- 165-XX-XX** BULK SAMPLE LOCATION
- AREA INCLUDED IN ASSESSMENT

CONFIRMED ASBESTOS CONTAINING MATERIALS:

- FLOOR TILE (12" GRAY) AND ASSOCIATED MASTIC (BLACK) APPROXIMATELY 160 SQUARE FEET
- DUCT MASTIC (GRAY) LOCATED ABOVE CEILINGS APPROXIMATELY 1,440 SQUARE FEET

C:\WORK IN PROGRESS\4213-20-165\4213-20-165.dwg

LIMITED ASBESTOS ASSESSMENT UPDATE

COLLETON COUNTY OFFICE BUILDING - FIRST FLOOR
31 KLEIN STREET
WALTERBORO, SOUTH CAROLINA

SCALE:
AS SHOWN
DATE:
7-02-2020
PROJECT NUMBER
4213-20-165
FIGURE NO.

1

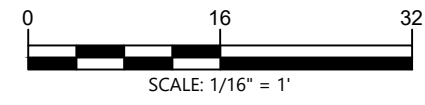

C:\WORK IN PROGRESS\4213-20-165\4213-20-165.dwg

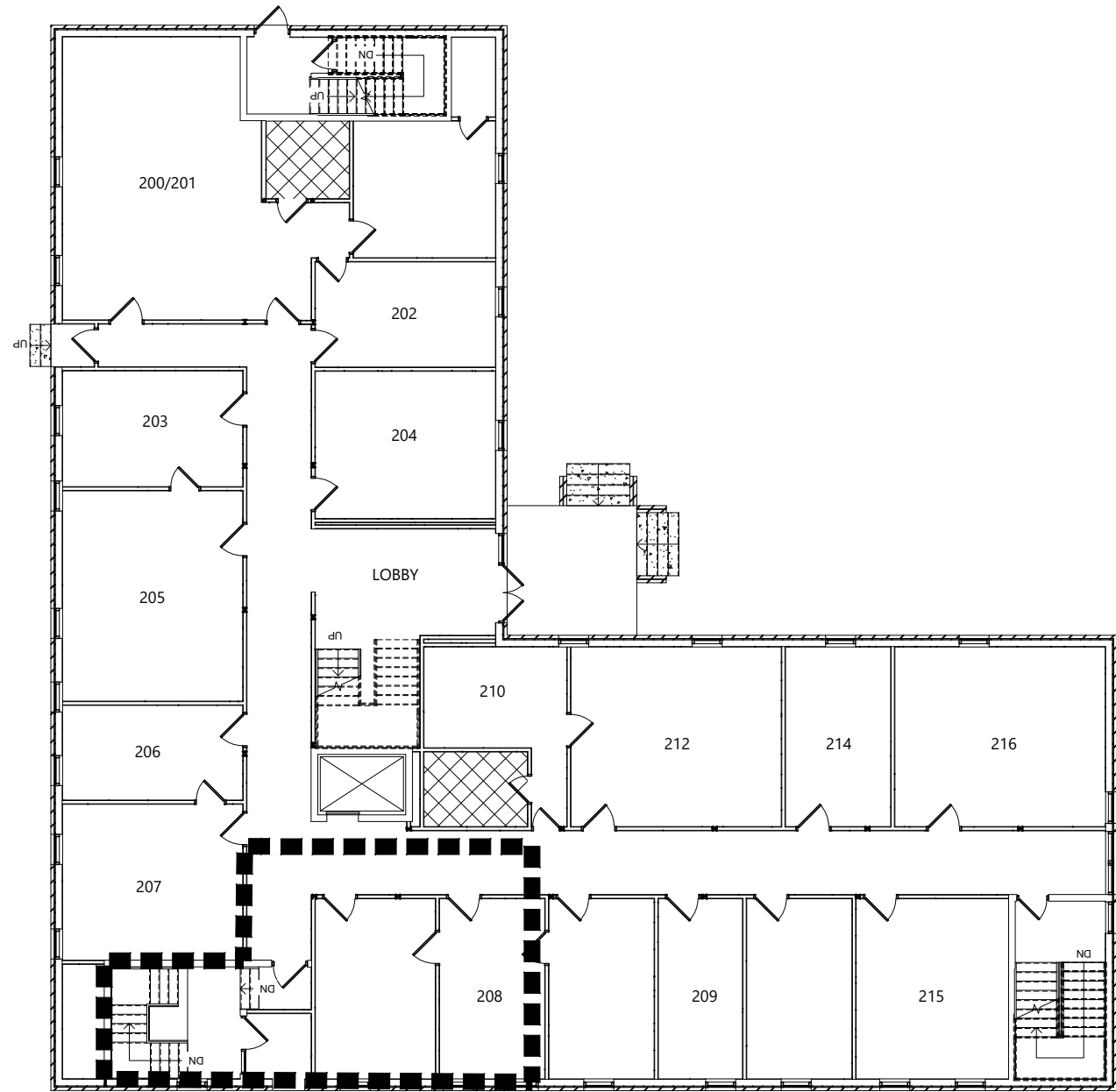

LEGEND

● 165-XX-XX BULK SAMPLE LOCATION

■■■■■ AREA INCLUDED IN ASSESSMENT

CONFIRMED ASBESTOS CONTAINING MATERIALS:

▨ FLOOR TILE (12' GRAY) AND ASSOCIATED MASTIC (BLACK)
-APPROXIMATELY 160 SQUARE FEET

■ DUCT MASTIC (GRAY) LOCATED ABOVE CEILINGS
-APPROXIMATELY 1,440 SQUARE FEET



LIMITED ASBESTOS ASSESSMENT UPDATE

COLLETON COUNTY OFFICE BUILDING - SECOND FLOOR
31 KLEIN STREET
WALTERBORO, SOUTH CAROLINA

SCALE:
AS SHOWN

DATE:
7-02-2020

PROJECT NUMBER
4213-20-165

FIGURE NO.

2

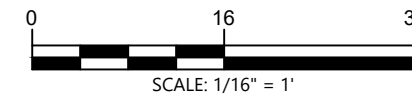

Appendix III- Copy of Inspector's SCDHEC Licenses



**South Carolina
Department of Health and Environmental Control**

Asbestos License

Bill Seaborn

SCDHEC ISSUED
Asbestos ID Card

William Seaborn



| | | |
|-------------------|-----------------|-----------------|
| CONSULTBI | BI-01317 | 01/06/21 |
| AIRSAMPLER | AS-00416 | 01/05/21 |

Expiration Date:

Air Sampler AS-00416
Building Inspector BI-01317

**Appendix IV – Laboratory Analysis Sheets and Chain of
Custody Records**



9771D Southern Pine Boulevard
 Charlotte, NC 28273
 704-940-1830 Fax 704-565-4929
 NVLAP Lab Code 102075-0

POLARIZED LIGHT MICROSCOPY

Performed by EPA 600/R-93/116 Method

Asbestos Analysis Summary

Client Name Charleston Office

620 Wando Park Blvd.
 Mt. Pleasant SC 29464

Date Received 6/26/2020

Client Job Glick Boehm Colleton Co 31 Klein St

Date Analyzed 6/26/2020

Job Number 4213-20-165

| Lab ID: | Sample #: | Appearance | Comments | Asbestos %/Type | Non-Asbestos Fibrous %/Type | Non-Fibrous %/Type |
|----------------|------------------|-------------------|-----------------|------------------------|------------------------------------|---------------------------|
| 20-8635A | 165-FT-01 | TAN NONFIBROUS | TILE | 3 CHRYSOTILE | | 97 OTHER |
| 20-8635B | 165-FT-01 | BLACK FIBROUS | MASTIC | 6 CHRYSOTILE | | 94 OTHER |

Analyzed by: Jane Wasilewski
Additional Comments:

Jane Wasilewski
 Laboratory Manager

For heterogeneous samples easily separated into subsamples, and for layered samples, each component is analyzed separately. ND = None Detected (Asbestos Not Present In Representative Sample). RCF= (Refractory Ceramic Fiber) The results relate only to the items tested. The sample may not be fully representative of the larger material in question. This sheet may not be reproduced except with permission from SME, Inc. This report may not be used to claim product endorsement by NVLAP or any agency of the U.S. Government. Although Polarized Light Microscopy (PLM/Dispersion Staining) (Method EPA 600/R-93/116) is the specified method for analysis of bulk material samples for asbestos under the EPA Asbestos Hazard Emergency Response Act, there have been reports that this method may not identify asbestos when fiber sizes are extremely small or if they are bound in a resinous material. Such materials include floor tile, mastic and asphaltic roofing. Currently, reanalysis by Transmission Electron Microscopy (TEM) to verify results of <1% or "None Detected" for these materials is recommended.

**Appendix V – Copy of the 2015 Limited Asbestos and Lead-Based
Paint Assessment**



November 19, 2015

Mead & Hunt, Inc.
878 South Lake Drive
Lexington, South Carolina 29072

Attention: Mr. Dave Yensan, AIA, LEED BD+C
dave.yensan@meadhunt.com

Reference: **Limited Asbestos and Lead-Based Paint Assessment**
Colleton County Service Center –First and Second Floor
31 Klein Street
Walterboro, South Carolina
S&ME Project No. 4213-15-257

Dear Mr. Yensan:

S&ME, Inc. (S&ME) is pleased to provide this report summarizing the asbestos bulk sampling we performed at the referenced site on October 23, 2015. Our services were performed in general accordance with S&ME Proposal No. 42-1501044R dated September 21, 2015. The enclosed report includes the executive summary, project background, assessment procedures, findings and results, and conclusions and recommendations for the proper treatment of asbestos containing materials.

This report is provided for the sole use of Mead & Hunt, Inc. Use of this report by any other parties will be at such party's sole risk and S&ME, Inc. disclaims liability for any such use or reliance by third parties. The results presented in this report are indicative of conditions only during the time of the assessment and of the specific areas referenced. The information provided in this assessment report should not be used as a bidding document, and field conditions should be verified.

We appreciate the opportunity to provide you with our industrial hygiene/environmental services. If you have any questions concerning this report, please call us at (843) 884-0005.

Sincerely,

S&ME, Inc.

Terry W. Richburg
Environmental Location Coordinator

James L. Killingsworth, CHMM
Environmental Services Area Manager, V.P.

**Limited Asbestos and Lead-Based Paint Assessment Report
Colleton County Service Center - First and Second Floor
31 Klein Street
Walterboro, South Carolina
S&ME Project No. 4213-15-257**

Assessment Performed by:

Steven C. Reichard

Steven C. Reichard (SCDHEC Accreditation# ASB-23216)

11-19-15

Date

Report Prepared by:

Terry W. Richburg

Terry W. Richburg, (SCDHEC Accreditation# MP-00110)

11-19-15

Date



Prepared for:
Mead & Hunt, Inc.
878 South Lake Drive
Lexington, South Carolina 29072

Prepared by:
S&ME, Inc.
620 Wando Park Boulevard
Mt Pleasant, SC 29464

November 19, 2015



Table of Contents

| | |
|---|----------|
| Executive Summary | 1 |
| Asbestos..... | 1 |
| Lead-based Paint Assessment | 2 |
| 1.0 Background | 3 |
| 1.1 Asbestos Assessment..... | 3 |
| 1.2 Lead-based Paint Assessment..... | 3 |
| 2.0 Asbestos Assessment..... | 3 |
| 2.1 Assessment Procedures..... | 3 |
| 2.2 Findings and Results | 4 |
| 2.3 Abbreviations and Hazard Assessment Key | 5 |
| 3.0 Lead-Based Paint Assessment | 6 |
| 3.1 Procedures | 6 |
| 3.2 Findings..... | 6 |
| 4.0 Conclusions and Recommendations | 6 |
| 4.1 Asbestos Recommendations | 7 |
| 4.2 Lead-based Paint Recommendations | 7 |

Appendices

| | |
|---|-----|
| Appendix I – Summary of Asbestos Results..... | i |
| Appendix II – Diagram of Bulk Sample Locations | ii |
| Appendix III – Copy of Inspector’s SCDHEC License | iii |
| Appendix IV – Laboratory Analysis Sheets and Chain of Custody Records | iv |
| Appendix V – Summary of XRF Lead Analyzer Readings..... | v |



Executive Summary

S&ME Inc. (S&ME) performed an asbestos and lead-based paint assessment on October 23, 2015, limited to the first and second floor of the Colleton County Service Building located at 31 Klein Street in Walterboro, South Carolina. The purpose of the assessment was to identify asbestos containing materials (ACMs) and lead based paint coatings in the referenced areas that will be impacted by planned renovation activities. The third floor, exterior and roof of the structure were not included in this assessment. The assessment also complies with the federal, state, and local asbestos requirements regarding identification of ACMs that will be disturbed due to renovation and/or demolition.

The Colleton County Service Building is a three-story building, approximately 21,000 square feet in size. The building is constructed of steel with exterior brick veneer and a flat built-up roof. Interior finishes include drywall walls and suspended acoustical ceiling tiles. The flooring was predominately vinyl floor tile. The facility was occupied and in operation on the day of our site visit.

Asbestos

The suspect ACMs sampled and analyzed as part of this assessment included acoustical ceiling tiles, vinyl floor tiles with associated mastics, mastics associated with rubber cove bases, drywall and associated joint compound, mastic associated with ductwork, stair tread and mastic, carpet mastic and window caulking. The Environmental Protection Agency (EPA) and the South Carolina Department of Health and Environmental Control (SCDHEC) define materials as asbestos containing if an asbestos content greater than one percent (>1%) is detected in a representative sample. Based on the bulk samples collected and analyzed as a part of this assessment, the following ACMs were identified:

Table -1 Summary of Confirmed Asbestos Containing Materials

| Material | HA | Location | Asbestos Type | Percent | Condition | Potential for Disturbance | *Approx. Quantity |
|---|-----|------------------|---------------|---------|-----------|---------------------------|-------------------|
| Floor tile (12" grey) and associated Mastic (black) | FT2 | See Figure 1 & 2 | Chrysotile | 2 | G, NF | PD | 160 SF |
| Mastic (grey) associated with ductwork | DM | See Figure 1 & 2 | Chrysotile | 6 | G, NF | PD | 2,880 SF |

*Note: The quantities are estimated and should be field verified for bidding purposes.

Abbreviations:

- HA = homogeneous area SF = square feet LF = linear foot
- G = good D = damaged NF = non friable F = friable
- LPD = low potential for disturbance PD = potential for disturbance PSD = potential for sig. disturbance

The identified floors tile and associated mastic, and mastic associated with ductwork are classified as Category I non-friable ACMs, in good condition, with a potential for disturbance due to the planned renovation activities. No asbestos was detected in the remaining bulk samples collected and analyzed. The EPA and OSHA define materials as asbestos containing if an asbestos content greater than one percent (>1%) is detected in a representative sample.



It should be noted that the building was occupied and open to the public on the day of our assessment. It should also be noted that batten insulation was located on the topside of the suspended ceilings, therefore access above the ceilings was limited.

We recommend proper removal and disposal of the identified ACMs, by a SCDHEC licensed asbestos abatement contractor, prior to renovation activities. If additional suspect ACMs not identified in this report are discovered during the planned renovation activities, bulk samples must be collected by a SCDHEC licensed inspector and analyzed for asbestos content prior to disturbance or disposal of the suspect materials. This report should also be provided to the contractor(s) to assist with compliance with applicable State and Federal regulations.

Lead-based Paint Assessment

A lead-based paint assessment was performed of representative painted components associated with the basement and first floor of the referenced facility. The components were analyzed using direct measurement X-Ray Fluorescence (XRF) technology using a Thermo Scientific XLp 302 (serial #25910). For the purpose of this assessment, painted surfaces with lead concentrations meeting the SCDHEC disposal limit (0.7 mg/cm²) are considered lead-based paint.

Based on the results of the representative painted components tested on October 23, 2015, no lead concentrations meeting the SCDHEC disposal limit of 0.7 mg/cm² were identified. Low levels of lead, which may be applicable to the OSHA regulations 29 CFR 1926.62 (Lead in Construction), were identified on the majority of the painted components tested. The OSHA does not recognize a threshold level of lead for definition purposes, only the airborne concentration of lead a worker is exposed.

Work activities affecting lead-containing paint coated surfaces (i.e. component removal, manual demolition, paint surface preparation, etc.), should be performed in accordance with the OSHA regulations 29 CFR 1926.62, including but not limited to training, initial exposure monitoring, the use of personal protective equipment, and medical surveillance.

Paint coatings may be present that contain low levels of lead that cannot be detected by X-ray fluorescence, which may be applicable to OSHA regulations 29 CFR 1926.62. The quantities reported by XRF may be useful in determining the relative risk associated with various demolition tasks, for example disturbances to paints with low lead levels may be less likely to result in airborne lead exposures in excess of the OSHA Action Level.

1.0 Background

S&ME was contracted by Mead and Hunt, Inc. to provide an asbestos and lead-based paint assessment of the interior of the first and second floor of the building located at 31 Klein Street in Walterboro, South Carolina, and the assessment was subsequently performed by S&ME on October 23, 2015. The purpose of the assessment was to identify asbestos containing materials (ACMs) and lead based paint coatings in the referenced areas that will be impacted by planned renovation activities. The second floor, exterior and roof of the structure were not included in this assessment. The assessment also complies with the federal, state, and local asbestos requirements regarding identification of ACMs that will be disturbed due to renovation and/or demolition.

The Colleton County Service Building is a three-story building, approximately 21,000 square feet in size. The building is constructed of steel with exterior brick veneer and a flat built-up roof. Interior finishes include drywall walls and suspended acoustical ceiling tiles. The flooring was predominately vinyl floor tile. The facility was occupied and in operation on the day of our site visit.

1.1 Asbestos Assessment

The asbestos assessment was conducted in the subject areas to assess, sample, and identify ACMs that will be disturbed, in accordance with regulatory requirements. The identification of ACMs will aid in the prevention of occupational exposures and/or environmental releases of airborne asbestos. Identification of ACMs also complies with Title 40 Code of the Federal Regulations, part 61, and State regulations 61-86.1 enforced by the South Carolina Department of Health and Environmental Control (SCDHEC), along with Title 29 Code of Federal Regulations, part 1926 enforced by the Occupational Safety and Health Administration (OSHA). The following sections describe the assessment procedures used, results of the suspect ACMs sampled and analyzed, and conclusions and recommendations related to ACMs.

1.2 Lead-based Paint Assessment

The lead-based paint assessment was conducted in the subject areas to assess, sample, and identify lead-based paint coatings that will be disturbed, in accordance with regulatory requirements. The identification of these materials will aid in the compliance of occupational exposure (OSHA) and/or environmental releases of airborne lead dust in accordance with OSHA 29 CFR 1926.62 (Lead in Construction) and provide information to determine proper disposal of lead-based paint coated components and debris in accordance with the SCDHEC and the Environmental Protection Agency (EPA).

2.0 Asbestos Assessment

2.1 Assessment Procedures

The assessment was performed by observing and sampling suspect ACMs, limited to the referenced areas of the facility. Significant destructive testing was not performed, therefore the possibility exists that suspect materials were undetected in inaccessible areas such as inside pipe chases, wall voids, or flooring overlays. If additional suspect ACMs are discovered during the planned destructive activities, bulk samples must be collected by a SCDHEC licensed inspector and analyzed for asbestos content.



A sampling strategy was developed to provide representative samples in accordance with the SCDHEC and EPA. Bulk samples of suspect ACMs were collected by a SCDHEC licensed inspector. The bulk samples were then extracted from suspect ACMs, recorded on a chain of custody record and submitted to our in-house laboratory for analysis by Polarized Light Microscopy (PLM). Transmission Electron Microscopy (TEM) for confirmation of non-friable organically bound materials reported negative via PLM were analyzed by *EMSL Analytical*. Both laboratories are located in Charlotte, North Carolina and accredited by the National Voluntary Laboratory Accreditation Program (NVLAP), which is administered by the National Institute of Standards and Technology.

Polarized Light Microscopy (PLM)

The suspect materials were analyzed by trained microscopists using PLM techniques coupled with dispersion staining in accordance with EPA Test Method Title 40 Code of Federal Regulations, Chapter I (1-1-87 edition), Part 763, Subpart F-APPENDIX A. This method identifies asbestos mineral fibers based on six optical characteristics: morphology, birefringence, refractive index, extinction angle, sign of elongation and dispersion staining colors. The laboratory analysis reports the specific type of asbestos identified (there are six asbestos minerals) and the percentage of asbestos present.

Transmission Electron Microscopy (TEM)

Suspect non-friable organically bound materials, exhibiting negative results via PLM analysis, were analyzed by trained microscopists via TEM, in accordance with SCDHEC requirements.

2.2 Findings and Results

The limited asbestos assessment performed on October 23, 2015 included a visual assessment and the bulk sampling and analysis of suspect ACMs, which included acoustical ceiling tiles, vinyl floor tiles with associated mastics, mastics associated with rubber cove bases, drywall and associated joint compound, mastic associated with ductwork, stair tread and mastic, carpet mastic and window caulking. The EPA and SCDHEC define materials as asbestos containing if an asbestos content >1% is detected in a representative sample.

Based on the bulk samples collected and analyzed as part of this assessment, the following ACMs were identified.

Table -1 Summary of Confirmed Asbestos Containing Materials

| Material | HA | Location | Asbestos Type | Percent | Condition | Potential for Disturbance | *Approx. Quantity |
|---|-----|------------------|---------------|---------|-----------|---------------------------|-------------------|
| Floor tile (12" grey) and associated Mastic (black) | FT2 | See Figure 1 & 2 | Chrysotile | 2 | G, NF | PD | 160 SF |
| Mastic (grey) associated with ductwork | DM | See Figure 1 & 2 | Chrysotile | 6 | G, NF | PD | 2,880 SF |

*Note: The quantities are estimated and should be field verified for bidding purposes.



Abbreviations:

HA = homogeneous area

SF = square feet

LF = linear foot

G = good

D = damaged

NF = non friable

F = friable

LPD = low potential for disturbance

PD = potential for disturbance

PSD = potential for sig. disturbance

The EPA classifies ACMs into two categories; friable and non-friable. A friable material creates a greater health hazard due to the fact that it may be "crumbled, pulverized or reduced to powder by the forces expected to act upon it in the course of demolition or renovation operations". The identified joint compound and associated drywall are classified as friable ACMs, in good condition, with a potential for significant disturbance due to the planned demolition activities. The identified floors tile and associated mastic, and mastic associated with ductwork are classified as Category I non-friable ACMs, in good condition, with a potential for disturbance due to the planned renovation activities. No asbestos was detected in the remaining bulk samples collected and analyzed. The EPA and OSHA define materials as asbestos containing if an asbestos content greater than one percent (>1%) is detected in a representative sample.

A summary of asbestos results is provided in Appendix I and summarizes the sample number, location, type of material tested, approximate quantity of the material sampled, condition of the material, and corresponding result for each sample. A diagram of the asbestos bulk sample locations and confirmed ACMs is provided in Appendix II, and a copy of the inspector's SCDHEC license is provided in Appendix III. Copies of the laboratory analyses and chain-of-custody records are provided in Appendix IV.

2.3 Abbreviations and Hazard Assessment Key

In accordance with the EPA and SCDHEC, confirmed ACM is assigned a hazard assessment based on its present condition and potential for disturbance. The hazard assessment is used as a tool for prioritization in remedial actions regarding ACM(s).

Present Condition

F = Friable

NF = Non-friable

G = Good (Very localized limited damage)

D = Damaged (Damage of less than 10% distributed and less than 25% localized)

SD = Significantly Damaged (Damage equal to or greater than 10% distributed, 25% localized)

Potential for Future Disturbance

LPD = Low Potential for Disturbance (Contact, Vibration, and Air Erosion all of Low Concern)

PD = Potential for Damage (Contact, Vibration, or Air Erosion of Moderate Concern)

PSD = Potential for Significant Damage (Contact, Vibration, or Air Erosion of High Concern)

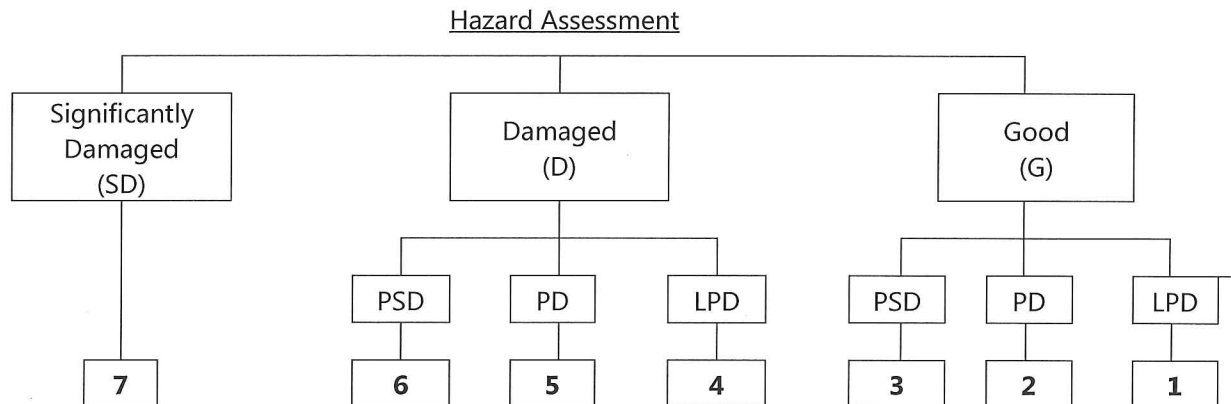

3.0 Lead-Based Paint Assessment

3.1 Procedures

Lead-based paint testing was performed on representative painted components associated with the subject areas of the subject building. The components were analyzed with a Thermo Scientific XLp-302 XRF spectrum analyzer (serial #25910). The suspect painted finishes were selected based on the color of the topcoat and the underlying paint layers and/or the substrate on which it was applied. The possibility exists that lead-based paint finishes are present in those inaccessible areas such as pipe chases, wall voids, etc. SCDHEC defines a lead-based paint as any paint containing lead at concentrations equaling 0.7 mg/cm² or greater by XRF testing. For the purpose of the assessment, paint containing 0.7 mg/cm² or greater was considered lead-based paint due to the planned activities. Lead-based paint, as defined by SCDHEC, on building components, requires disposal in a Class II or Class III lined landfill.

OSHA does not recognize a threshold level of lead for definition purposes, only the airborne concentration of lead a worker is exposed. The current OSHA regulations recognize an airborne action level of 30 micrograms per cubic meter (µg/m³) during an eight-hour day and a permissible exposure limit of 50 µg/m³.

3.2 Findings

A lead-based paint assessment was performed on October 23, 2015, limited to the first and second floor of the referenced building to identify lead-based paints and lead-containing paints. None of the painted components tested exhibited lead concentrations meeting the SCDHEC disposal limit of 0.7 mg/cm², however the majority of surfaces tested exhibited low lead levels which may be applicable to the OSHA regulations 29 CFR 1926.62 (Lead in Construction).

The summary of XRF readings is provided in Appendix V, and should be reviewed in full.

4.0 Conclusions and Recommendations

The asbestos and lead-based paint assessment performed on October 23, 2015, limited to the first and second floor of the Colleton County Service Building located at 31 Klein Street in Walterboro, South



Carolina identified Category I non-friable ACMs, and low levels of lead in paint which may be applicable to the standards of OSHA. No lead levels applicable to the SCDHEC and EPA disposal standards were identified in the subject areas. This report should be provided to the contractor(s) to assist with compliance with applicable State and Federal regulations.

It should be noted that the building was occupied and open to the public on the day of our assessment. It should also be noted that batten insulation was located on the topside of the suspended ceilings, therefore access above the ceilings was limited.

4.1 Asbestos Recommendations

We recommend proper removal and disposal of the identified ACMs, by a SCDHEC licensed asbestos abatement contractor, prior to the planned renovation activities or activities that will disturb the identified ACMs. If additional suspect ACMs not identified in this report are discovered during the planned renovation and demolition activities, bulk samples must be collected by a SCDHEC licensed inspector and analyzed for asbestos content prior to disturbance or disposal of the suspect materials.

4.2 Lead-based Paint Recommendations

Destructive actions to paint containing detectable levels of lead (e.g. component removal, demolition, sanding, grinding, burning, paint preparation, etc.) will require the contractor comply with the standards of the OSHA regulations 29 CFR 1926.62 (Lead in Construction), including but not limited to training, initial exposure monitoring, the use of personal protective equipment, and medical surveillance. Paint coatings may be present that contain low levels of lead that cannot be detected by X-ray fluorescence, which may be applicable to OSHA regulations 29 CFR 1926.62. The quantities reported by XRF may be useful in determining the relative risk associated with various demolition tasks, for example disturbances to paints with low lead levels may be less likely to result in airborne lead exposures in excess of the OSHA Action Level.

Appendix I – **Summary of Asbestos Results**



Table I: Summary of Asbestos Results

| Sample No. | Location | Material | ² Approx. Quantity | Asbestos Type | ¹ Percent | Condition | Potential for Disturbance | Hazard Assessment |
|---------------------|-----------------|--|-------------------------------|---------------|----------------------|-----------|---------------------------|-------------------|
| FT1-01 | 200 | Floor tile (12" grey) Mastic (black) | 140 SF | ND | NA | NA | NA | NA |
| FT1-02 | 200 | | | ND | NA | NA | NA | NA |
| ³ FT1-03 | 201 | | | ND | NA | NA | NA | NA |
| FT2-01 | Vault in 200 | Floor tile (12" grey) Mastic (black) | 160 SF | Chrysotile | 2 | G, NF | PD | 2 |
| FT2-02 | Vault in 200 | | | Chrysotile | 2 | G, NF | PD | 2 |
| ³ FT2-03 | Closet in 210 | | | Not Analyzed | NA | NA | NA | NA |
| FT3-01 | 123 | Floor tile (12" grey) Mastic (yellow) | 216 SF | ND | NA | NA | NA | NA |
| FT3-02 | 123 | | | ND | NA | NA | NA | NA |
| ³ FT3-03 | 123 | | | ND | NA | NA | NA | NA |
| CB1-01 | 111 | Mastic (beige) associated with rubber cove base | 448 LF | ND | NA | NA | NA | NA |
| CB1-02 | 112 | | | ND | NA | NA | NA | NA |
| ³ CB1-03 | 111 | | | ND | NA | NA | NA | NA |
| CB2-01 | 210 | Mastic (cream) associated with rubber cove base | 960 LF | ND | NA | NA | NA | NA |
| CB2-02 | 2nd floor Lobby | | | ND | NA | NA | NA | NA |
| ³ CB2-03 | 212 | | | ND | NA | NA | NA | NA |
| WC-01 | Exterior window | Window caulking | 432 LF | ND | NA | NA | NA | NA |
| WC-02 | Exterior window | | | ND | NA | NA | NA | NA |
| ³ WC-03 | Exterior window | | | ND | NA | NA | NA | NA |
| ST-01 | Stainwell | Stair tread (black) Mastic (yellow) | 62 SF | ND | NA | NA | NA | NA |
| ST-02 | Stainwell | | | ND | NA | NA | NA | NA |
| ³ ST-03 | Stainwell | | | ND | NA | NA | NA | NA |



Table I: Summary of Asbestos Results

| Sample No. | Location | Material | ² Approx. Quantity | Asbestos Type | ¹ Percent | Condition | Potential for Disturbance | Hazard Assessment |
|--------------------|-----------|--|-------------------------------|---------------|----------------------|-----------|---------------------------|-------------------|
| CG-01 | 119 | Carpet glue | 10,000 SF | ND | NA | NA | NA | NA |
| CG-02 | 100 | | | ND | NA | NA | NA | NA |
| ³ CG-03 | 214 | | | ND | NA | NA | NA | NA |
| CT1-01 | 119 | Ceiling tile (2'x4' light worm-track) | 4,250 SF | ND | NA | NA | NA | NA |
| CT1-02 | 115 | | | ND | NA | NA | NA | NA |
| CT1-03 | 109 | | | ND | NA | NA | NA | NA |
| CT2-01 | 1st floor | Ceiling tile (2'x4' heavy worm-track) | 4,000 SF | ND | NA | NA | NA | NA |
| CT2-02 | 116 | | | ND | NA | NA | NA | NA |
| CT2-03 | 111 | | | ND | NA | NA | NA | NA |
| DM-01 | 1st floor | Mastic (grey) associated with ductwork | 2,880 SF | Chrysotile | 6 | G, NF | PD | 2 |
| DM-02 | 110 | | | Chrysotile | 6 | G, NF | PD | 2 |
| ³ DM-03 | 205 | | | Not Analyzed | NA | NA | NA | NA |
| SR-01 | 122 | Drywall | | ND | NA | NA | NA | NA |
| SR-02 | 209 | | | ND | NA | NA | NA | NA |
| SR-03 | 2nd floor | | | ND | NA | NA | NA | NA |
| JC-01 | 122 | Joint compound | 6,700 SF | ND | NA | NA | NA | NA |
| JC-02 | 209 | | | ND | NA | NA | NA | NA |
| JC-03 | 2nd floor | | | ND | NA | NA | NA | NA |
| JC-04 | 205 | | | ND | NA | NA | NA | NA |
| JC-05 | 215 | | | ND | NA | NA | NA | NA |
| JC-06 | 210 | | | ND | NA | NA | NA | NA |
| JC-07 | 207 | | | ND | NA | NA | NA | NA |



Table I: Summary of Asbestos Results

| Sample No. | Location | Material | ² Approx. Quantity | Asbestos Type | ¹ Percent | Condition | Potential for Disturbance | Hazard Assessment |
|------------|----------|----------------------|-------------------------------|---------------|----------------------|-----------|---------------------------|-------------------|
| CT3-01 | 209 | Ceiling tile (2'x4') | 300 SF | ND | NA | NA | NA | NA |
| CT3-02 | 215 | | | ND | NA | NA | NA | NA |
| CT3-03 | 209 | | | ND | NA | NA | NA | NA |

ND = No Asbestos Detected

NA = Not Applicable

SF = square feet

LF = linear feet

LPD = low potential for disturbance

PD = potential for disturbance

PSD = potential for significant disturbance

G = good

D = damaged

SD = significantly damaged

F = friable

NF = non-friable

¹EPA, SCDHEC and OSHA defines a material as asbestos containing if an asbestos content greater than one percent (>1%) is detected in a representative sample.

²Quantities are estimated, and should not be used for bidding purposes, as field conditions should be verified.

³Samples analyzed by TEM to confirm negative results reported by PLM analysis.

**Appendix II – Diagram of Bulk Sample Locations and
Confirmed ACMs**

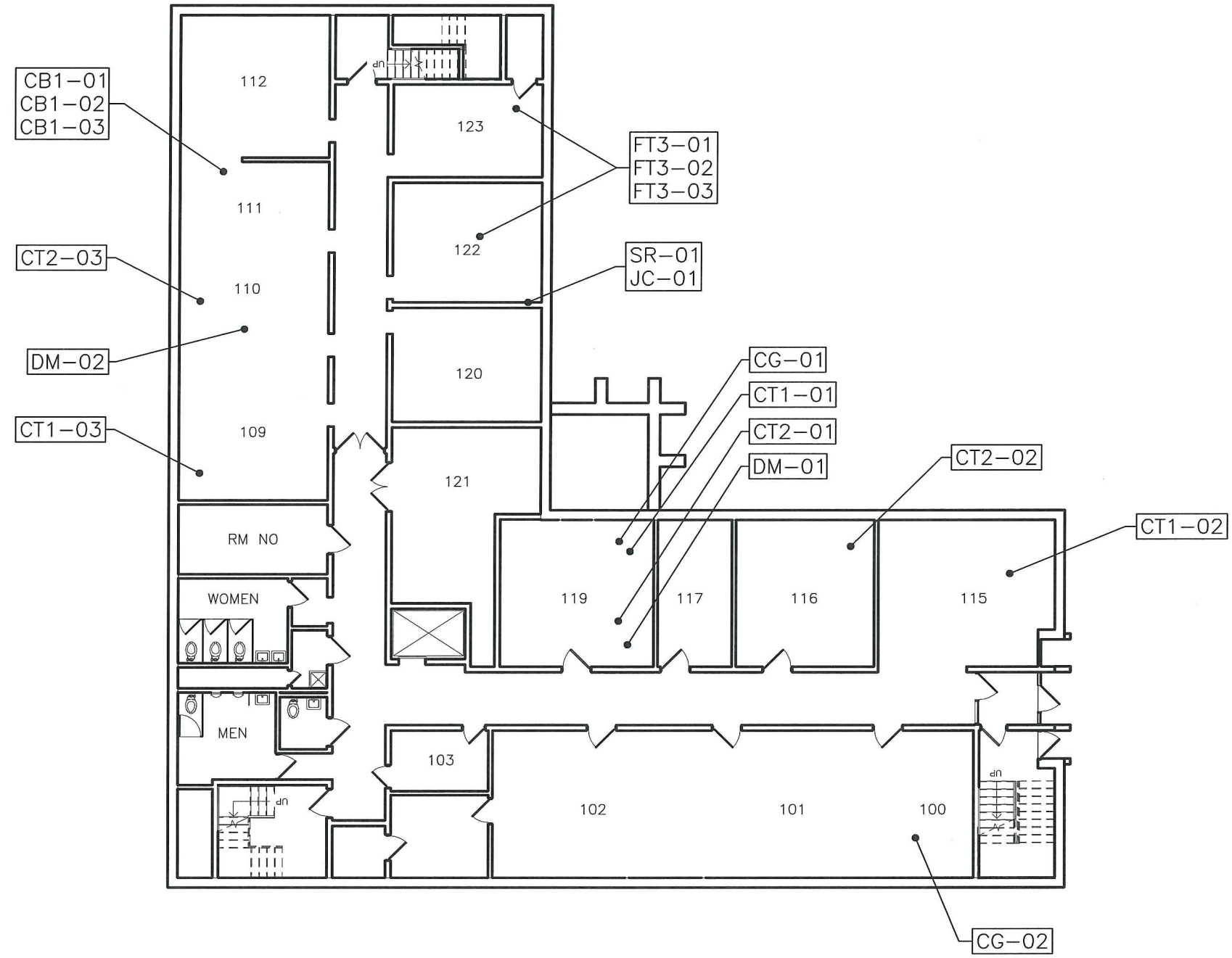

LEGEND

XX-XX BULK SAMPLE LOCATION

CONFIRMED ASBESTOS CONTAINING MATERIALS:

DUCT MASTIC (GREY) LOCATED ABOVE CEILINGS
-APPROXIMATELY 1,440 SQUARE FEET

NOTE: NO LEAD-BASED PAINT MEETING SCDHEC AND EPA DISPOSAL REQUIREMENTS WERE IDENTIFIED.

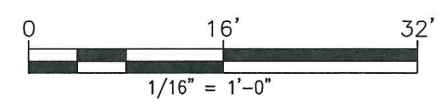

| | | |
|---|------------------|------------------|
| LIMITED ASBESTOS AND LEAD-BASED PAINT ASSESSMENT | | |
| FIRST FLOOR | | |
| 31 KLEIN STREET WALTERBORO, SOUTH CAROLINA | | |
| SCALE: AS SHOWN | DRAWN BY: LAJ | APPROVED BY: TWR |
| PROJECT NO. 4213-15-257 | DATE: 11-19-2015 | FIGURE NO. 1 |

C:\drawings\4213_2015\257_Harrison\4213-15-257.dwg

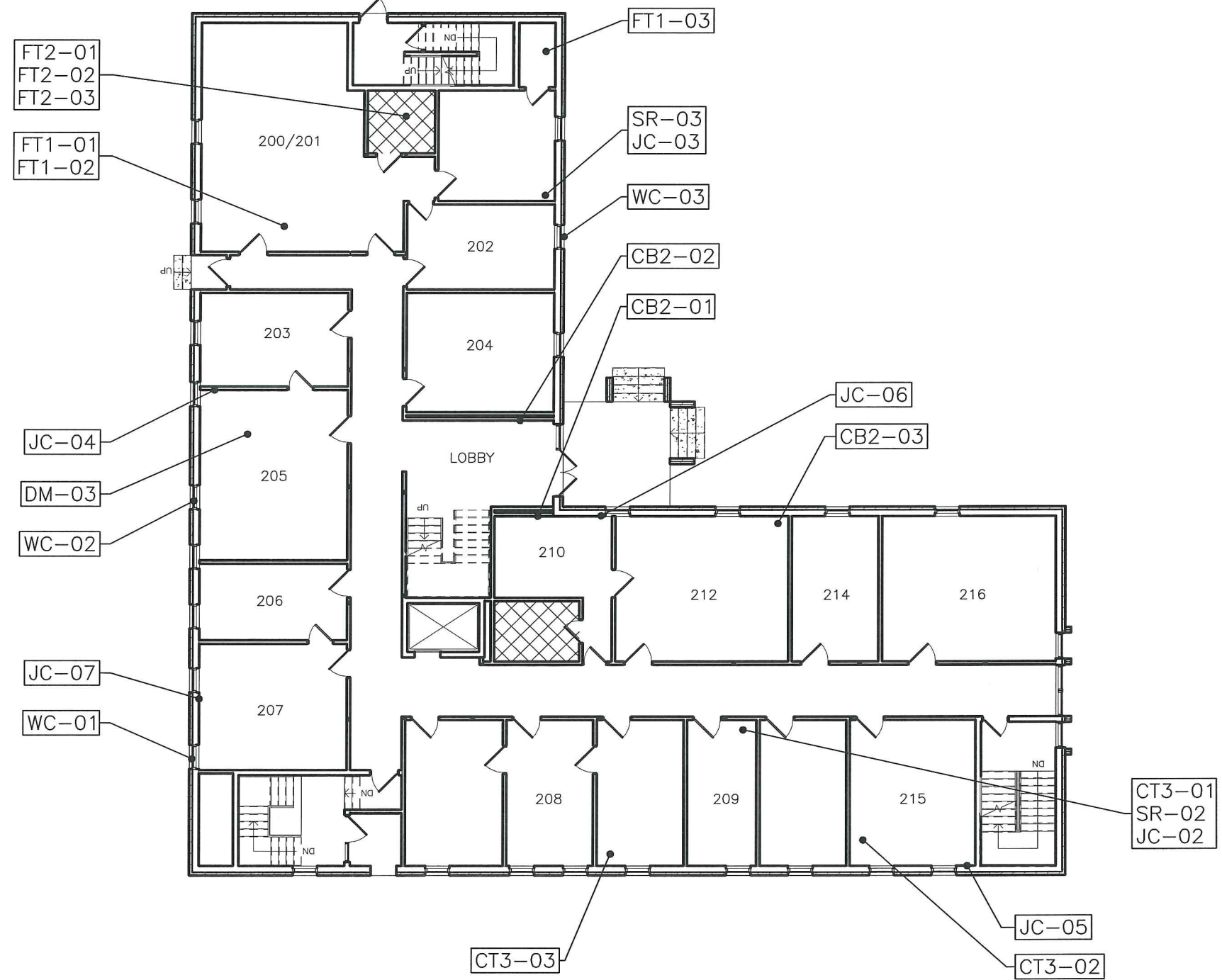

LEGEND

XX-XX BULK SAMPLE LOCATION

CONFIRMED ASBESTOS CONTAINING MATERIALS:

- FLOOR TILE (12' GREY) AND ASSOCIATED MASTIC (BLACK) - APPROXIMATELY 160 SQUARE FEET
- DUCT MASTIC (GREY) LOCATED ABOVE CEILINGS - APPROXIMATELY 1,440 SQUARE FEET

NOTE: NO LEAD-BASED PAINT MEETING SCDHEC AND EPA DISPOSAL REQUIREMENTS WERE IDENTIFIED.

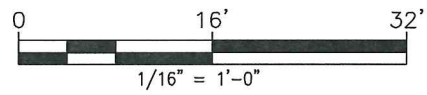

| | | |
|---|------------------|------------------|
| LIMITED ASBESTOS AND LEAD-BASED PAINT ASSESSMENT | | |
| SECOND FLOOR | | |
| 31 KLEIN STREET WALTERBORO, SOUTH CAROLINA | | |
| SCALE: AS SHOWN | DRAWN BY: LAJ | APPROVED BY: TWR |
| PROJECT NO. 4213-15-257 | DATE: 11-19-2015 | FIGURE NO. 2 |

D:\drawings\4213\2015\357 - Interiors\4213-15-257.dwg

Appendix III – Copy of Inspector’s SCDHEC License

SCDHEC ISSUED
Asbestos ID Card

Steven C Reichard

Expires

CONSULTBI
AIRSAMPLER

ASB-23216 01/15/16
AS-00152 01/14/16



SCDHEC ISSUED
Asbestos ID Card

Terry W. Richburg

Expires



| | | |
|------------|----------|----------|
| CONSULTPD | PD-00054 | 08/04/16 |
| CONSULTMP | MP-00110 | 01/15/16 |
| AIRSAMPLER | AS-00150 | 01/14/16 |

**Appendix IV – Laboratory Analysis Sheets and Chain of
Custody Records**



9771D Southern Pine Boulevard
 Charlotte, NC 28273
 704-940-1830 Fax 704-565-4929
 NVLAP Lab Code 102075-0

POLARIZED LIGHT MICROSCOPY
 Performed by EPA 600/R-93/116 Method

Asbestos Analysis Summary

Client Name Charleston Branch
Client Job Colleton Cnty Harrelson Bldg

620 Wando Park Blvd.
 Mt. Pleasant SC 29464

Date Received 10/26/2015
Date Analyzed 10/27/2015

Job Number 4213-15-257

| Lab ID: | Sample #: | Appearance | Comments | Asbestos %/Type | Non-Asbestos Fibrous %/Type | Non-Fibrous %/Type |
|-----------|-----------|------------------|----------|-----------------|-----------------------------|--------------------|
| 15-11715A | FT1-01 | GREY NONFIBROUS | TILE | ND | | 100 OTHER |
| 15-11715B | FT1-01 | BLACK NONFIBROUS | MASTIC | ND | | 100 OTHER |
| 15-11716A | FT1-02 | GREY NONFIBROUS | TILE | ND | | 100 OTHER |
| 15-11716B | FT1-02 | BLACK NONFIBROUS | MASTIC | ND | | 100 OTHER |

Analyzed by: 
 Jane Wasilewski
 Laboratory Manager

 Jane Wasilewski
 Laboratory Manager

For heterogeneous samples easily separated into subsamples, and for layered samples, each component is analyzed separately. ND = None Detected (Asbestos Not Present in Representative Sample), RCF= (Refractory Ceramic Fiber) The results relate only to the items tested. The sample may not be fully representative of the larger material in question. This sheet may not be reproduced except with permission from SME, Inc. This report may not be used to claim product endorsement by NVLAP or any agency of the U.S. Government. Although Polarized Light Microscopy (PLM/Dispersion Staining) (Method EPA 600/R-93/116) is the specified method for analysis of bulk material samples for asbestos under the EPA Asbestos Hazard Emergency Response Act, there have been reports that this method may not identify asbestos when fiber sizes are extremely small or if they are bound in a resinous material. Such materials include floor tile, mastic and asphaltic roofing. Currently, reanalysis by Transmission Electron Microscopy (TEM) to verify results of <1% or "None Detected" for these materials is recommended.

Job Number 4213-15-257

| Lab ID: | Sample #: | Appearance | Comments | Asbestos %/Type | Non-Asbestos Fibrous %/Type | Non-Fibrous %/Type |
|-----------|-----------|-------------------|----------|-----------------|-----------------------------|--------------------|
| 15-11718A | FT2-01 | GREY NONFIBROUS | TILE | 2 CHRYSOTILE | | 98 OTHER |
| 15-11718B | FT2-01 | BLACK NONFIBROUS | MASTIC | 2 CHRYSOTILE | | 98 OTHER |
| 15-11719A | FT2-02 | GREY NONFIBROUS | TILE | 2 CHRYSOTILE | | 98 OTHER |
| 15-11719B | FT2-02 | BLACK NONFIBROUS | MASTIC | 2 CHRYSOTILE | | 98 OTHER |
| 15-11721A | FT3-01 | GREY NONFIBROUS | TILE | ND | | 100 OTHER |
| 15-11721B | FT3-01 | YELLOW NONFIBROUS | MASTIC | ND | | 100 OTHER |

Analyzed by: Jane Wasilewski
Additional Comments:

Jane Wasilewski
Laboratory Manager

For heterogeneous samples easily separated into subsamples, and for layered samples, each component is analyzed separately. ND = None Detected (Asbestos Not Present In Representative Sample), RCF= (Refractory Ceramic Fiber) The results relate only to the items tested. The sample may not be fully representative of the larger material in question. This sheet may not be reproduced except with permission from SME, Inc. This report may not be used to claim product endorsement by NVLAP or any agency of the U.S. Government. Although Polarized Light Microscopy (PLM/Dispersion Staining) (Method EPA 600/R-93/116) is the specified method for analysis of bulk material samples for asbestos under the EPA Asbestos Hazard Emergency Response Act, there have been reports that this method may not identify asbestos when fiber sizes are extremely small or if they are bound in a resinous material. Such materials include floor tile, mastic and asphaltic roofing. Currently, reanalysis by Transmission Electron Microscopy (TEM) to verify results of <1% or "None Detected" for these materials is recommended.

Job Number 4213-15-257

| Lab ID: | Sample #: | Appearance | Comments | Asbestos %/Type | Non-Asbestos Fibrous %/Type | Non-Fibrous %/Type |
|-----------|-----------|-------------------|----------|-----------------|-----------------------------|--------------------|
| 15-11722A | FT3-02 | GREY NONFIBROUS | TILE | ND | | 100 OTHER |
| 15-11722B | FT3-02 | YELLOW NONFIBROUS | MASTIC | ND | | 100 OTHER |
| 15-11724 | CB1-01 | BEIGE NONFIBROUS | | ND | | 100 OTHER |
| 15-11725 | CB1-02 | BEIGE NONFIBROUS | | ND | | 100 OTHER |
| 15-11727 | CB2-01 | CREAM NONFIBROUS | | ND | | 100 OTHER |
| 15-11728 | CB2-02 | CREAM NONFIBROUS | | ND | | 100 OTHER |

Analyzed by: Jane Wasilewski
Additional Comments:

Jane Wasilewski
Laboratory Manager

For heterogeneous samples easily separated into subsamples, and for layered samples, each component is analyzed separately. ND = None Detected (Asbestos Not Present in Representative Sample), RCF= (Refractory Ceramic Fiber) The results relate only to the items tested. The sample may not be fully representative of the larger material in question. This sheet may not be reproduced except with permission from SME, Inc. This report may not be used to claim product endorsement by NVLAP or any agency of the U.S. Government. Although Polarized Light Microscopy (PLM/Dispersion Staining) (Method EPA 600/R-93/116) is the specified method for analysis of bulk material samples for asbestos under the EPA Asbestos Hazard Emergency Response Act, there have been reports that this method may not identify asbestos when fiber sizes are extremely small or if they are bound in a resinous material. Such materials include floor tile, mastic and asphaltic roofing. Currently, reanalysis by Transmission Electron Microscopy (TEM) to verify results of <1% or "None Detected" for these materials is recommended.

Job Number 4213-15-257

| Lab ID: | Sample #: | Appearance | Comments | Asbestos %/Type | Non-Asbestos Fibrous %/Type | Non-Fibrous %/Type |
|-----------|-----------|-------------------|-------------|-----------------|-----------------------------|--------------------|
| 15-11730 | WC-01 | GREY PLIABLE | | ND | | 100 OTHER |
| 15-11731 | WC-02 | GREY PLIABLE | | ND | | 100 OTHER |
| 15-11733A | ST-01 | BLACK PLIABLE | STAIR TREAD | ND | | 100 OTHER |
| 15-11733B | ST-01 | YELLOW NONFIBROUS | MASTIC | ND | | 100 OTHER |
| 15-11734A | ST-02 | BLACK PLIABLE | STAIR TREAD | ND | | 100 OTHER |
| 15-11734B | ST-02 | YELLOW NONFIBROUS | MASTIC | ND | | 100 OTHER |

Analyzed by: Jane Wasilewski
Additional Comments:

Jane Wasilewski
Laboratory Manager

For heterogeneous samples easily separated into subsamples, and for layered samples, each component is analyzed separately. ND = None Detected (Asbestos Not Present in Representative Sample), RCF= (Refractory Ceramic Fiber) The results relate only to the items tested. The sample may not be fully representative of the larger material in question. This sheet may not be reproduced except with permission from SME, Inc. This report may not be used to claim product endorsement by NVLAP or any agency of the U.S. Government. Although Polarized Light Microscopy (PLM/Dispersion Staining) (Method EPA 600/R-93/116) is the specified method for analysis of bulk material samples for asbestos under the EPA Asbestos Hazard Emergency Response Act, there have been reports that this method may not identify asbestos when fiber sizes are extremely small or if they are bound in a resinous material. Such materials include floor tile, mastic and asphaltic roofing. Currently, reanalysis by Transmission Electron Microscopy (TEM) to verify results of <1% or "None Detected" for these materials is recommended.

Job Number 4213-15-257

| Lab ID: | Sample #: | Appearance | Comments | Asbestos %/Type | Non-Asbestos Fibrous %/Type | Non-Fibrous %/Type |
|----------|-----------|-------------------|----------|-----------------|-----------------------------|--------------------|
| 15-11736 | CG-01 | YELLOW NONFIBROUS | | ND | | 100 OTHER |
| 15-11737 | CG-02 | YELLOW NONFIBROUS | | ND | | 100 OTHER |
| 15-11739 | DM-01 | GREY PLIABLE | | 6 CHRYSOTILE | | 94 OTHER |
| 15-11740 | DM-02 | GREY PLIABLE | | 6 CHRYSOTILE | | 94 OTHER |
| 15-11742 | SR-01 | TAN/BEIGE FIBROUS | | ND | 5 CELLULOSE | 95 GYPSUM |
| 15-11743 | SR-02 | TAN/BEIGE FIBROUS | | ND | 20 CELLULOSE | 80 GYPSUM |

Analyzed by: Jane Wasilewski
 Additional Comments:

Jane Wasilewski
 Laboratory Manager

For heterogeneous samples easily separated into subsamples, and for layered samples, each component is analyzed separately. ND = None Detected (Asbestos Not Present in Representative Sample), RCF= (Refractory Ceramic Fiber) The results relate only to the items tested. The sample may not be fully representative of the larger material in question. This sheet may not be reproduced except with permission from SME, Inc. This report may not be used to claim product endorsement by NVLAP or any agency of the U.S. Government. Although Polarized Light Microscopy (PLM/Dispersion Staining) (Method EPA 600/R-93/116) is the specified method for analysis of bulk material samples for asbestos under the EPA Asbestos Hazard Emergency Response Act, there have been reports that this method may not identify asbestos when fiber sizes are extremely small or if they are bound in a resinous material. Such materials include floor tile, mastic and asphaltic roofing. Currently, reanalysis by Transmission Electron Microscopy (TEM) to verify results of <1% or "None Detected" for these materials is recommended.

Job Number 4213-15-257

| Lab ID: | Sample #: | Appearance | Comments | Asbestos %/Type | Non-Asbestos Fibrous %/Type | Non-Fibrous %/Type |
|----------|-----------|-------------------|----------|-----------------|--------------------------------|--------------------|
| 15-11744 | SR-03 | TAN/BEIGE FIBROUS | | ND | 10 CELLULOSE | 90 GYPSUM |
| 15-11745 | CT1-01 | GREY FIBROUS | | ND | 65 CELLULOSE 2 MINERAL WOOL | 33 PERLITE |
| 15-11746 | CT1-02 | GREY FIBROUS | | ND | 65 CELLULOSE 2 MINERAL WOOL | 33 PERLITE |
| 15-11747 | CT1-03 | GREY FIBROUS | | ND | 65 CELLULOSE 2 MINERAL WOOL | 33 PERLITE |
| 15-11748 | CT2-01 | GREY FIBROUS | | ND | 65 CELLULOSE 2 MINERAL WOOL | 33 PERLITE |
| 15-11749 | CT2-02 | GREY FIBROUS | | ND | 65 CELLULOSE 2 MINERAL WOOL | 33 PERLITE |

Analyzed by: Jane Wasilewski
Additional Comments:

Jane Wasilewski
Laboratory Manager

For heterogeneous samples easily separated into subsamples, and for layered samples, each component is analyzed separately. ND = None Detected (Asbestos Not Present in Representative Sample), RCF= (Refractory Ceramic Fiber) The results relate only to the items tested. The sample may not be fully representative of the larger material in question. This sheet may not be reproduced except with permission from SME, Inc. This report may not be used to claim product endorsement by NYLAP or any agency of the U.S. Government. Although Polarized Light Microscopy (PLM/Dispersion Staining) (Method EPA 600/R-93/116) is the specified method for analysis of bulk material samples for asbestos under the EPA Asbestos Hazard Emergency Response Act, there have been reports that this method may not identify asbestos when fiber sizes are extremely small or if they are bound in a resinous material. Such materials include floor tile, mastic and asphaltic roofing. Currently, reanalysis by Transmission Electron Microscopy (TEM) to verify results of <1% or "None Detected" for these materials is recommended.

Job Number 4213-15-257

| Lab ID: | Sample #: | Appearance | Comments | Asbestos %/Type | Non-Asbestos Fibrous %/Type | Non-Fibrous %/Type |
|----------|-----------|------------------|----------|-----------------|---------------------------------|--------------------|
| 15-11750 | CT2-03 | GREY FIBROUS | | ND | 65 CELLULOSE 2 MINERAL WOOL | 33 PERLITE |
| 15-11751 | CT3-01 | GREY FIBROUS | | ND | 75 MINERAL WOOL 23 CELLULOSE | 2 PERLITE |
| 15-11752 | CT3-02 | GREY FIBROUS | | ND | 75 MINERAL WOOL 23 CELLULOSE | 2 PERLITE |
| 15-11753 | CT3-03 | GREY FIBROUS | | ND | 75 MINERAL WOOL 23 CELLULOSE | 2 PERLITE |
| 15-11754 | JC-01 | WHITE NONFIBROUS | | ND | | 100 OTHER |
| 15-11755 | JC-02 | WHITE NONFIBROUS | | ND | | 100 OTHER |

Analyzed by: Jane Wasilewski
Additional Comments:

Jane Wasilewski
Laboratory Manager

For heterogeneous samples easily separated into subsamples, and for layered samples, each component is analyzed separately. ND = None Detected (Asbestos Not Present in Representative Sample), RCF= (Refractory Ceramic Fiber) The results relate only to the items tested. The sample may not be fully representative of the larger material in question. This sheet may not be reproduced except with permission from SME, Inc. This report may not be used to claim product endorsement by NVLAP or any agency of the U.S. Government. Although Polarized Light Microscopy (PLM/Dispersion Staining) (Method EPA 600/R-93/116) is the specified method for analysis of bulk material samples for asbestos under the EPA Asbestos Hazard Emergency Response Act, there have been reports that this method may not identify asbestos when fiber sizes are extremely small or if they are bound in a resinous material. Such materials include floor tile, mastic and asphaltic roofing. Currently, reanalysis by Transmission Electron Microscopy (TEM) to verify results of <1% or "None Detected" for these materials is recommended.

Job Number 4213-15-257

| Lab ID: | Sample #: | Appearance | Comments | Asbestos %/Type | Non-Asbestos Fibrous %/Type | Non-Fibrous %/Type |
|----------|-----------|------------------|----------|-----------------|-----------------------------|--------------------|
| 15-11756 | JC-03 | WHITE NONFIBROUS | | ND | | 100 OTHER |
| 15-11757 | JC-04 | WHITE NONFIBROUS | | ND | | 100 OTHER |
| 15-11758 | JC-05 | WHITE NONFIBROUS | | ND | | 100 OTHER |
| 15-11759 | JC-06 | WHITE NONFIBROUS | | ND | | 100 OTHER |
| 15-11760 | JC-07 | WHITE NONFIBROUS | | ND | | 100 OTHER |

Analyzed by: Jane Wasilewski
Additional Comments:

Jane Wasilewski
Laboratory Manager

For heterogeneous samples easily separated into subsamples, and for layered samples, each component is analyzed separately. ND = None Detected (Asbestos Not Present in Representative Sample), RCF= (Refractory Ceramic Fiber) The results relate only to the items tested. The sample may not be fully representative of the larger material in question. This sheet may not be reproduced except with permission from SME, Inc. This report may not be used to claim product endorsement by NVLAP or any agency of the U.S. Government. Although Polarized Light Microscopy (PLM/Dispersion Staining) (Method EPA 600/R-93/116) is the specified method for analysis of bulk material samples for asbestos under the EPA Asbestos Hazard Emergency Response Act, there have been reports that this method may not identify asbestos when fiber sizes are extremely small or if they are bound in a resinous material. Such materials include floor tile, mastic and asphaltic roofing. Currently, reanalysis by Transmission Electron Microscopy (TEM) to verify results of <1% or "None Detected" for these materials is recommended.



BULK SAMPLE
CHAIN OF CUSTODY RECORD

Page 1 of 3

| PROJECT NO. 4213-15-257 | | PROJECT NAME COLLETON CNTY | | RELINQUISHED BY: S. Beckhard | DATE 10/23/15 | RECEIVED BY: | DATE 10/26/15 | | | |
|----------------------------|------------------|-------------------------------|------------|---------------------------------|-------------------|----------------|------------------|-----------|-------------------|----------------------|
| FACILITY HARRELSON BLDG | | DATE TAKEN 10/23/15 | | RELINQUISHED BY: | DATE | RECEIVED BY: | DATE | | | |
| SAMPLER(S) SR/FS | | LAB NUMBER | | RELINQUISHED BY: | DATE | RECEIVED BY: | DATE | | | |
| SAMPLE # | HOMOGENEOUS AREA | MATERIAL TYPE | LAB NUMBER | DATE ANALYZED | ANALYSTS INITIALS | ASBESTOS + N/D | ARCHIVE NUMBER | DATE ARCH | ARCHIVER INITIALS | SPECIAL INSTRUCTIONS |
| FT1-01 | 1 | J | 15-11715 | | | | | | | w/ BLK MASTR |
| 02 | | | 16 | | | | | | | |
| 03 | | | 17 | | | | | | | TEM IF REQUIRED |
| FT2-01 | 2 | J | 18 | | | | | | | w/ BLK MASTR |
| 02 | | | 17 | | | | | | | |
| 03 | | | 20 | | | | | | | TEM IF REQUIRED |
| FT3-01 | 3 | J | 21 | | | | | | | w/ GLUE |
| 02 | | | 22 | | | | | | | |
| 03 | | | 23 | | | | | | | TEM IF REQUIRED |
| CB1-01 | 4 | COVERBASE | 24 | | | | GLUE ONLY | | | |
| 02 | | | 25 | | | | " | " | | |
| 03 | | | 26 | | | | " | " | | TEM IF REQUIRED |
| CB2-01 | 5 | COVERBASE | 27 | | | | GLUE ONLY | | | |
| 02 | | | 28 | | | | " | " | | |
| 03 | | | 17 29 | | | | " | " | | TEM IF REQUIRED |

ALL SAMPLES WILL BE DISPOSED OF NINETY DAYS AFTER ANALYSIS UNLESS OTHERWISE REQUESTED

MATERIAL TYPES

- A - <4" Pipe Fitting
- B - 4-8" Pipe Fitting
- C - 9-14" Pipe Fitting
- D - >14" Pipe Fitting
- E - <4" Pipe
- F - 4-8" Pipe
- G - 9-14" Pipe
- H - >14" Pipe
- I - Spray-On/Trowel
- J - Floor Tile
- K - Tanks/Boiler
- L - A.H.U. Insul.
- M - A.H.U. Exp. Jt.
- N - Ceiling/Wall Tile
- O - Fiberboard
- P - Other

(See notes - Front or back)

TAT

PLM - 3 DAY
TEM - 3 DAY



BULK SAMPLE
CHAIN OF CUSTODY RECORD

Page 2 of 3

| PROJECT NO. | | PROJECT NAME | | RELINQUISHED BY: | DATE | TIME | RECEIVED BY: | | |
|----------------|------------------|-----------------|------------|-------------------|----------------|----------------|--------------|-------------------|----------------------|
| 423-15-257 | | COLLETON Cnty | | S. Richard | 10/23/15 | | 10/26/15 | | |
| FACILITY | | DATE TAKEN | | RELINQUISHED BY: | DATE | TIME | RECEIVED BY: | | |
| HARRELSON BLDG | | 10/23/15 | | | | | | | |
| SAMPLER(S) | | DATE TAKEN | | RELINQUISHED BY: | DATE | TIME | RECEIVED BY: | | |
| SR/FS | | 10/23/15 | | | | | | | |
| SAMPLE # | HOMOGENEOUS AREA | MATERIAL TYPE | LAB NUMBER | ANALYSTS INITIALS | ASBESTOS + N/D | ARCHIVE NUMBER | DATE ARCH | ARCHIVER INITIALS | SPECIAL INSTRUCTIONS |
| WC-01 | 6 | WINDOW CAULKING | 15-11730 | | | | | | |
| 02 | | | 31 | | | | | | |
| 03 | | | 32 | | | | | | |
| ST-01 | 7 | STAIR TREAD | 33 | | | | | | TEM IF REQUIRED |
| 02 | | | 34 | | | | | | |
| 03 | | | 35 | | | | | | TEM IF REQUIRED |
| CG-01 | 8 | CARPET GLUE | 36 | | | | | | |
| 02 | | | 37 | | | | | | |
| 03 | | | 38 | | | | | | |
| DM-01 | 9 | DUST MASTE | 39 | | | | | | TEM IF REQUIRED |
| 02 | | | 40 | | | | | | |
| 03 | | | 41 | | | | | | |
| SR-01 | 10 | SHEET ROCK | 42 | | | | | | TEM IF REQUIRED |
| 02 | | | 43 | | | | | | |
| 03 | | | 11744 | | | | | | |

ALL SAMPLES WILL BE DISPOSED OF NINETY DAYS AFTER ANALYSIS UNLESS OTHERWISE REQUESTED

MATERIAL TYPES

- A - <4" Pipe Fitting
- B - 4-8" Pipe Fitting
- C - 9-14" Pipe Fitting
- D - >14" Pipe Fitting
- E - <4" Pipe
- F - 4-8" Pipe
- G - 9-14" Pipe
- H - >14" Pipe
- I - Spray-On/Trowel
- J - Floor Tile
- K - Tanks/Boiler
- L - A.H.U. Insul.
- M - A.H.U. Exp. Jt.
- N - Ceiling/Wall Tile
- O - Fiberboard
- P - Other

(See notes - Front or back)

TAT
PLM - 3 DAY
TEM - 3 DAY



BULK SAMPLE

CHAIN OF CUSTODY RECORD

Page 3 of 3

| PROJECT NO. 4213-15-257 | | PROJECT NAME COLLETON CPTY | | RELINQUISHED BY: S. Richard | DATE 10/23/15 | RECEIVED BY: | | | | |
|----------------------------|------------------|-------------------------------|------------|--------------------------------|-------------------|----------------|----------------|-----------|-------------------|----------------------|
| FACILITY HARRELSON BODG | | DATE TAKEN 10/23/15 | | RELINQUISHED BY: | DATE 10/26/15 | RECEIVED BY: | | | | |
| SAMPLER(S) SR/FS | | | | RELINQUISHED BY: | DATE | RECEIVED BY: | | | | |
| SAMPLE # | HOMOGENEOUS AREA | MATERIAL TYPE | LAB NUMBER | DATE ANALYZED | ANALYSTS INITIALS | ASBESTOS + N/D | ARCHIVE NUMBER | DATE ARCH | ARCHIVER INITIALS | SPECIAL INSTRUCTIONS |
| CT1-01 | 11 | N | 15-71745 | | | | | | | |
| 02 | | | 46 | | | | | | | |
| 03 | | | 47 | | | | | | | |
| CT2-01 | 12 | N | 48 | | | | | | | |
| 02 | | | 49 | | | | | | | |
| 03 | | | 50 | | | | | | | |
| CT3-01 | 13 | N | 51 | | | | | | | |
| 02 | | | 52 | | | | | | | |
| 03 | | | 53 | | | | | | | |
| JE-01 | 14 | I | 54 | | | | | | | |
| 02 | | | 55 | | | | | | | |
| 03 | | | 56 | | | | | | | |
| 04 | | | 57 | | | | | | | |
| 05 | | | 58 | | | | | | | |
| 06 | | | 59 | | | | | | | |
| 07 | | | 11760 | | | | | | | |

ALL SAMPLES WILL BE DISPOSED OF NINETY DAYS AFTER ANALYSIS UNLESS OTHERWISE REQUESTED

MATERIAL TYPES

- A - <4" Pipe Fitting
 - B - 4-8" Pipe Fitting
 - C - 9-14" Pipe Fitting
 - D - >14" Pipe Fitting
 - E - <4" Pipe
 - F - 4-8" Pipe
 - G - 9-14" Pipe
 - H - >14" Pipe
 - I - Spray-On/Trowel
 - J - Floor Tile
 - K - Tanks/Boiler
 - L - A.H.U. Insul.
 - M - A.H.U. Exp. Jt.
 - N - Ceiling/Wall Tile
 - O - Fiberboard
 - P - Other
- (See notes - Front or back)

TAT
PLM - 3 DAY
TEAM - 3 DAY

**EMSL Analytical, Inc.**

376 Crompton Street, Charlotte, NC 28273
 Phone/Fax: (704) 525-2205 / (704) 525-2382
<http://www.EMSL.com> charlottelab@emsl.com

EMSL Order: 411508087
 CustomerID: SMEI54
 CustomerPO: 62962
 ProjectID:

Attn: **Jane Wasilewski**
S&ME, Inc.
9771D Southern Pine Blvd.
Charlotte, NC 28273

Phone:
 Fax: (704) 565-4929
 Received: 10/27/15 1:50 PM
 Analysis Date: 10/29/2015
 Collected:

Project: 4213-15-257

**Test Report: Asbestos Analysis of Non-Friable Organically Bound Materials by TEM
 via EPA/600/R-93/116 Section 2.5.5.1**

| SAMPLE ID | DESCRIPTION | APPEARANCE | % MATRIX MATERIAL | % NON-ASBESTOS FIBERS | ASBESTOS TYPES |
|--------------------------|------------------|-------------------------------------|-------------------|-----------------------|----------------------|
| FT1-03 411508087-0001 | - Tile | Gray Non-Fibrous Homogeneous | 99.0 | 1.0 Fibrous (other) | No Asbestos Detected |
| FT1-03 411508087-0002 | - Mastic (Black) | Black Non-Fibrous Homogeneous | 99.1 | 0.91 Fibrous (other) | No Asbestos Detected |
| FT3-03 411508087-0003 | - Tile | White Non-Fibrous Homogeneous | 100 | None | No Asbestos Detected |
| FT3-03 411508087-0004 | - Mastic | Tan Non-Fibrous Homogeneous | 100 | <0.31 Fibrous (other) | No Asbestos Detected |
| CB1-03 411508087-0005 | - Mastic Only | Gray Non-Fibrous Homogeneous | 100 | <0.1 Fibrous (other) | No Asbestos Detected |
| CB2-03 411508087-0006 | - Mastic Only | Beige Non-Fibrous Homogeneous | 99.9 | 0.12 Fibrous (other) | No Asbestos Detected |
| WC-03 411508087-0007 | - Caulk | Gray Non-Fibrous Homogeneous | 99.6 | 0.37 Fibrous (other) | No Asbestos Detected |
| CG-03 411508087-0008 | - Mastic | Tan Non-Fibrous Homogeneous | 100 | None | No Asbestos Detected |
| ST-03 411508087-0009 | - Stair Tread | Black Non-Fibrous Homogeneous | 100 | None | No Asbestos Detected |

Analyst(s)

Aaron Hartley (10)

Lee Plumley, Laboratory Manager
 or other approved signatory

This laboratory is not responsible for % asbestos in total sample when the residue only is submitted for analysis. The above report relates only to the items tested. This report may not be reproduced, except in full, without written approval by EMSL Analytical, Inc. Samples received in good condition unless otherwise noted. Unless requested by the client, building materials manufactured with multiple layers (i.e. linoleum, wallboard, etc.) are reported as a single sample.
 Samples analyzed by EMSL Analytical, Inc. Charlotte, NC

Initial report from 10/29/2015 13:52:26



EMSL Analytical, Inc.

376 Crompton Street, Charlotte, NC 28273
Phone/Fax: (704) 525-2205 / (704) 525-2382
<http://www.EMSL.com> charlottelab@emsl.com

EMSL Order: 411508087
CustomerID: SMEI54
CustomerPO: 62962
ProjectID:

Attn: **Jane Wasilewski**
S&ME, Inc.
9771D Southern Pine Blvd.
Charlotte, NC 28273

Phone:
Fax: (704) 565-4929
Received: 10/27/15 1:50 PM
Analysis Date: 10/29/2015
Collected:

Project: 4213-15-257

**Test Report: Asbestos Analysis of Non-Friable Organically Bound Materials by TEM
via EPA/600/R-93/116 Section 2.5.5.1**

| SAMPLE ID | DESCRIPTION | APPEARANCE | % MATRIX MATERIAL | % NON-ASBESTOS FIBERS | ASBESTOS TYPES |
|-------------------------|-------------|-----------------------------------|-------------------|-----------------------|----------------------|
| ST-03 411508087-0010 | - Mastic | Tan Non-Fibrous Homogeneous | 100 | None | No Asbestos Detected |

Analyst(s) _____

Aaron Hartley (10)

Lee Plumley, Laboratory Manager
or other approved signatory

This laboratory is not responsible for % asbestos in total sample when the residue only is submitted for analysis. The above report relates only to the items tested. This report may not be reproduced, except in full, without written approval by EMSL Analytical, Inc. Samples received in good condition unless otherwise noted. Unless requested by the client, building materials manufactured with multiple layers (i.e. linoleum, wallboard, etc.) are reported as a single sample.
Samples analyzed by EMSL Analytical, Inc. Charlotte, NC

Initial report from 10/29/2015 13:52:26



EMSL ANALYTICAL, INC.
LABORATORY-PRODUCTS-TRAINING

Asbestos Chain of Custody

EMSL Order Number (Lab Use Only):

411508087

EMSL ANALYTICAL, INC.
376 CROMPTON ST
CHARLOTTE, NC 28273
PHONE: 704-525-2205
FAX: 704-525-2382

| | | | |
|---------------------------------------|--------------------|--|-----------------------|
| Company : S&ME Inc. | | EMSL-Bill to: <input type="checkbox"/> Same <input checked="" type="checkbox"/> Different If Bill to is Different note instructions in Comments** | |
| Street: 9771D Southern Pine Blvd. | | Third Party Billing requires written authorization from third party | |
| City: Charlotte | State/Province: NC | Zip/Postal Code: 28273 | Country: |
| Report To (Name): Jane Wasilewski | | Telephone #: 704-940-1830 | |
| Email Address: jwasilewski@smeinc.com | | Fax #: | Purchase Order: 62962 |
| Project Name/Number: | | Please Provide Results: <input type="checkbox"/> Fax <input checked="" type="checkbox"/> Email | |
| U.S. State Samples Taken: | | CT Samples: <input type="checkbox"/> Commercial/Taxable <input type="checkbox"/> Residential/Tax Exempt | |

Turnaround Time (TAT) Options - Please Check

3 Hour 6 Hour 24 Hour 48 Hour 72 Hour 96 Hour 1 Week 2 Week

*For TEM Air 3 hr through 6 hr, please call ahead to schedule. There is a premium charge for 3 Hour TEM AHERA or EPA Level II TAT. You will be asked to sign an authorization form for this service. Analysis completed in accordance with EMSL's Terms and Conditions located in the Analytical Price Guide.

| | | |
|--|---|---|
| PCM - Air <input type="checkbox"/> Check if samples are from NY <input type="checkbox"/> NIOSH 7400 <input type="checkbox"/> w/ OSHA 8hr. TWA PLM - Bulk (reporting limit) <input type="checkbox"/> PLM EPA 600/R-93/116 (<1%) <input type="checkbox"/> PLM EPA NOB (<1%) Point Count <input type="checkbox"/> 400 (<0.25%) <input type="checkbox"/> 1000 (<0.1%) Point Count w/Gravimetric <input type="checkbox"/> 400 (<0.25%) <input type="checkbox"/> 1000 (<0.1%) <input type="checkbox"/> NYS 198.1 (friable in NY) <input type="checkbox"/> NYS 198.6 NOB (non-friable-NY) <input type="checkbox"/> NIOSH 9002 (<1%) | TEM - Air <input type="checkbox"/> 4-4.5hr TAT (AHERA only) <input type="checkbox"/> AHERA 40 CFR, Part 763 <input type="checkbox"/> NIOSH 7402 <input type="checkbox"/> EPA Level II <input type="checkbox"/> ISO 10312 TEM - Bulk <input checked="" type="checkbox"/> TEM EPA NOB <input type="checkbox"/> NYS NOB 198.4 (non-friable-NY) <input type="checkbox"/> Chatfield SOP <input type="checkbox"/> TEM Mass Analysis-EPA 600 sec. 2.5 TEM - Water: EPA 100.2 Fibers >10µm <input type="checkbox"/> Waste <input type="checkbox"/> Drinking All Fiber Sizes <input type="checkbox"/> Waste <input type="checkbox"/> Drinking | TEM- Dust <input type="checkbox"/> Microvac - ASTM D 5755 <input type="checkbox"/> Wipe - ASTM D6480 <input type="checkbox"/> Carpet Sonication (EPA 600/J-93/167) Soil/Rock/Vermiculite <input type="checkbox"/> PLM CARB 435 - A (0.25% sensitivity) <input type="checkbox"/> PLM CARB 435 - B (0.1% sensitivity) <input type="checkbox"/> TEM CARB 435 - B (0.1% sensitivity) <input type="checkbox"/> TEM CARB 435 - C (0.01% sensitivity) <input type="checkbox"/> TEM Qual. via Filtration Technique <input type="checkbox"/> TEM Qual. via Drop-Mount Technique Other: <input type="checkbox"/> |
|--|---|---|

Check For Positive Stop - Clearly Identify Homogenous Group Filter Pore Size (Air Samples): 0.8µm 0.45µm

Samplers Name: _____ Samplers Signature: _____

| Sample # | Sample Description | Volume/Area (Air) HA # (Bulk) | Date/Time Sampled |
|----------|--------------------|----------------------------------|----------------------|
| F71-03 | Tile | | |
| ↓ | Mastic (Black) | | |
| FT3-03 | Tile | | |
| ↓ | Mastic | | |
| CB1-03 | Mastic only | | |
| CB2-03 | Mastic only | | |
| WC-03 | caulk | | |
| CG-03 | Mastic | | |

Client Sample # (s): - Total # of Samples: 10

Relinquished (Client): _____ Date: 10/27/15 Time: _____

Received (Lab): *Kyle N...* Date: 10/27/15 Time: 1:50 pm W/IN

Comments/Special Instructions: Bill to S&ME, Inc., 9751 Southern Pine Blvd., Charlotte NC 28273

4213-15-257

Appendix V – Summary of XRF Lead Analyzer Readings



| XLN No. | Site | Floor | Side | Room | Component | Color | Substrate | Condition | Results | Action Level | Lead | Units |
|---------|-----------------|-------|------|----------|-------------|-------|-----------|-----------|----------|--------------|------|--------------------|
| 1 | | | | | | | | CALIBRATE | | | 1 | mg/cm ² |
| 2 | | | | | | | | CALIBRATE | | | 1.1 | mg/cm ² |
| 3 | | | | | | | | CALIBRATE | | | 1.1 | mg/cm ² |
| 4 | 31 Klein Street | B | A | 102 | Wall | Beige | CMU | Intact | Negative | 0.7 | 0 | mg/cm ² |
| 5 | 31 Klein Street | B | B | 102 | Wall | Beige | CMU | Intact | Negative | 0.7 | 0.02 | mg/cm ² |
| 6 | 31 Klein Street | B | B | 102 | Door | Stain | CMU | Intact | Negative | 0.7 | 0 | mg/cm ² |
| 7 | 31 Klein Street | B | B | 102 | Door | Brown | Metal | Intact | Negative | 0.7 | 0.01 | mg/cm ² |
| 8 | 31 Klein Street | B | D | 119 | Door | Brown | Metal | Intact | Negative | 0.7 | 0 | mg/cm ² |
| 9 | 31 Klein Street | B | D | 119 | Door | Stain | Wood | Intact | Negative | 0.7 | 0 | mg/cm ² |
| 10 | 31 Klein Street | B | D | 119 | Door Casing | Brown | Wood | Intact | Negative | 0.7 | 0.06 | mg/cm ² |
| 11 | 31 Klein Street | B | B | 119 | Wall | Beige | CMU | Intact | Negative | 0.7 | 0 | mg/cm ² |
| 12 | 31 Klein Street | B | C | 119 | Wall | Beige | CMU | Intact | Negative | 0.7 | 0.01 | mg/cm ² |
| 13 | 31 Klein Street | B | A | 109 | Wall | Beige | CMU | Intact | Negative | 0.7 | 0 | mg/cm ² |
| 14 | 31 Klein Street | B | C | 109 | Wall | Beige | CMU | Intact | Negative | 0.7 | 0 | mg/cm ² |
| 15 | 31 Klein Street | B | C | 109 | Door | Stain | Wood | Intact | Negative | 0.7 | 0 | mg/cm ² |
| 16 | 31 Klein Street | B | C | 109 | Door Casing | Brown | Metal | Intact | Negative | 0.7 | 0.01 | mg/cm ² |
| 17 | 31 Klein Street | B | C | Hall | Wall | Beige | CMU | Intact | Negative | 0.7 | 0 | mg/cm ² |
| 18 | 31 Klein Street | B | A | Hall | Wall | Beige | CMU | Intact | Negative | 0.7 | 0 | mg/cm ² |
| 19 | 31 Klein Street | B | A | Bathroom | Wall | Grey | Ceramic | Intact | Negative | 0.7 | 0.3 | mg/cm ² |
| 20 | 31 Klein Street | B | D | Bathroom | Wall | Grey | Ceramic | Intact | Negative | 0.7 | 0.08 | mg/cm ² |
| 21 | 31 Klein Street | B | D | Bathroom | Floor | Grey | Ceramic | Intact | Negative | 0.7 | 0 | mg/cm ² |
| 22 | 31 Klein Street | 1 | D | 20 | Wall | Beige | Drywall | Intact | Negative | 0.7 | 0 | mg/cm ² |
| 23 | 31 Klein Street | 1 | B | 20 | Wall | Beige | Drywall | Intact | Negative | 0.7 | 0 | mg/cm ² |
| 24 | 31 Klein Street | 1 | B | 20 | Baseboard | Beige | Wood | Intact | Negative | 0.7 | 0 | mg/cm ² |
| 25 | 31 Klein Street | 1 | B | 20 | Door | Brown | Metal | Intact | Negative | 0.7 | 0 | mg/cm ² |
| 26 | 31 Klein Street | 1 | B | 20 | Door | Stain | Wood | Intact | Negative | 0.7 | 0 | mg/cm ² |
| 27 | 31 Klein Street | 1 | B | 212 | Door | Stain | Wood | Intact | Negative | 0.7 | 0 | mg/cm ² |
| 28 | 31 Klein Street | 1 | B | 212 | Door | Brown | Metal | Intact | Negative | 0.7 | 0 | mg/cm ² |
| 29 | 31 Klein Street | 1 | C | 212 | Wall | Beige | Drywall | Intact | Negative | 0.7 | 0 | mg/cm ² |
| 30 | 31 Klein Street | 1 | C | 212 | Wall | Beige | Drywall | Intact | Negative | 0.7 | 0 | mg/cm ² |
| 31 | 31 Klein Street | 1 | A | 206 | Wall | Beige | Drywall | Intact | Negative | 0.7 | 0 | mg/cm ² |
| 32 | 31 Klein Street | 1 | A | 206 | Door | Brown | Metal | Intact | Negative | 0.7 | 0.01 | mg/cm ² |
| 33 | 31 Klein Street | 1 | A | 206 | Door | Stain | Wood | Intact | Negative | 0.7 | 0 | mg/cm ² |
| 34 | 31 Klein Street | 1 | C | 204 | Door | Stain | Wood | Intact | Negative | 0.7 | 0 | mg/cm ² |
| 35 | 31 Klein Street | 1 | C | 204 | Door | Brown | Metal | Intact | Negative | 0.7 | 0.01 | mg/cm ² |
| 36 | 31 Klein Street | 1 | C | 204 | Wall | Beige | Drywall | Intact | Negative | 0.7 | 0 | mg/cm ² |



| XLN No. | Site | Floor | Side | Room | Component | Color | Substrate | Condition | Results | Action Level | Lead | Units |
|---------|-----------------|-------|------|------|-------------|-------|-----------|-----------|----------|--------------|------|--------------------|
| 37 | 31 Klein Street | 1 | B | 200 | Wall | Beige | Drywall | Intact | Negative | 0.7 | 0 | mg/cm ² |
| 38 | 31 Klein Street | 1 | B | 200 | Door | Brown | Metal | Intact | Negative | 0.7 | 0 | mg/cm ² |
| 39 | 31 Klein Street | 1 | B | 200 | Baseboard | Brown | Wood | Intact | Negative | 0.7 | 0 | mg/cm ² |
| 40 | 31 Klein Street | 1 | A | 200 | Handrail | Brown | Metal | Intact | Negative | 0.7 | 0 | mg/cm ² |
| 41 | 31 Klein Street | 1 | A | 200 | Door | Brown | Metal | Intact | Negative | 0.7 | 0.02 | mg/cm ² |
| 42 | 31 Klein Street | 1 | A | 200 | Door Casing | Brown | Metal | Intact | Negative | 0.7 | 0.01 | mg/cm ² |
| 43 | 31 Klein Street | 1 | A | 200 | Window | Brown | Metal | Intact | Negative | 0.7 | 0.14 | mg/cm ² |
| 44 | 31 Klein Street | 1 | D | 200 | Window | Brown | Metal | Intact | Negative | 0.7 | 0.21 | mg/cm ² |
| 45 | | | | | | | | CALIBRATE | | | 0.8 | mg/cm ² |
| 46 | | | | | | | | CALIBRATE | | | 0.21 | mg/cm ² |
| 47 | | | | | | | | CALIBRATE | | | 0.4 | mg/cm ² |

mg/cm² = milligram per square centimeter
 SCDHEC requires special disposal for paint containing lead >0.7 mg/cm²
 OSHA does not recognize a concentration of lead for definition purposes, only the airborne concentration a worker is exposed.
Bold = Paint Readings meeting or exceeding SCDHEC disposal level of 0.7 mg/cm²

SECTION 01 32 16
CONSTRUCTION PROGRESS SCHEDULE**PART 1 GENERAL****101 SECTION INCLUDES**

- A. Preliminary schedule.
- B. Construction progress schedule, bar chart type.

102 REFERENCES

- A. AGC (CPSM) - Construction Planning and Scheduling Manual; 2004.
- B. M-H (CPM) - CPM in Construction Management - Project Management with CPM; O'Brien; 2006.

103 SUBMITTALS

- A. Within 10 days after date of Agreement, submit preliminary schedule defining planned operations for the first 60 days of Work, with a general outline for remainder of Work.
- B. If preliminary schedule requires revision after review, submit revised schedule within 10 days.
- C. Within 20 days after review of preliminary schedule, submit draft of proposed complete schedule for review.
- D. Within 10 days after joint review, submit complete schedule.
- E. Submit updated schedule with each Application for Payment.

104 QUALITY ASSURANCE

- A. Scheduler: Contractor's personnel or specialist Consultant specializing in CPM scheduling with one years minimum experience in scheduling construction work of a complexity comparable to this Project, and having use of computer facilities capable of delivering a detailed graphic printout within 48 hours of request.

105 SCHEDULE FORMAT

- A. Listings: In chronological order according to the start date for each activity. Identify each activity with the applicable specification section number.

PART 2 PRODUCTS - NOT USED**PART 3 EXECUTION****301 PRELIMINARY SCHEDULE**

- A. Prepare preliminary schedule in the form of a horizontal bar chart.

302 CONTENT

- A. Show complete sequence of construction by activity, with dates for beginning and completion of each element of construction.
- B. Denote critical path items.
- C. Identify each item by specification section number.
- D. Include critical submittal items
- E. Show accumulated percentage of completion of each item, and total percentage of Work completed, as of the first day of each month.
- F. Indicate delivery dates for owner-furnished products.
- G. Provide legend for symbols and abbreviations used.

303 BAR CHARTS

- A. Include a separate bar for each major portion of Work or operation.
- B. Identify the first work day of each week.

304 NETWORK ANALYSIS

- A. Prepare network analysis diagrams and supporting mathematical analyses using the Critical Path Method.
- B. Illustrate order and interdependence of activities and sequence of work; how start of a given activity depends on completion of preceding activities, and how completion of the activity may restrain start of subsequent activities.
- C. Mathematical Analysis: Tabulate each activity of detailed network diagrams, using calendar dates, and identify for each activity:
 - 1. Preceding and following event numbers.
 - 2. Activity description.
 - 3. Estimated duration of activity, in maximum 15 day intervals.
 - 4. Earliest start date.
 - 5. Earliest finish date.
 - 6. Actual start date.
 - 7. Actual finish date.
 - 8. Latest start date.
 - 9. Latest finish date.
 - 10. Total and free float; float time shall accrue to Owner and to Owner's benefit.
 - 11. Monetary value of activity, keyed to Schedule of Values.
 - 12. Percentage of activity completed.
 - 13. Responsibility.
- D. Analysis Program: Capable of accepting revised completion dates, and recomputation of all dates and float.
- E. Required Reports: List activities in sorts or groups:
 - 1. By preceding work item or event number from lowest to highest.
 - 2. By amount of float, then in order of early start.

305 REVIEW AND EVALUATION OF SCHEDULE

- A. Participate in joint review and evaluation of schedule with Architect at each submittal.
- B. Evaluate project status to determine work behind schedule and work ahead of schedule.
- C. After review, revise as necessary as result of review, and resubmit within 10 days.

306 UPDATING SCHEDULE

- A. Maintain schedules to record actual start and finish dates of completed activities.
- B. Indicate progress of each activity to date of revision, with projected completion date of each activity.
- C. Annotate diagrams to graphically depict current status of Work.
- D. Identify activities modified since previous submittal, major changes in Work, and other identifiable changes.
- E. Indicate changes required to maintain Date of Substantial Completion.
- F. Submit reports required to support recommended changes.

307 DISTRIBUTION OF SCHEDULE

- A. Distribute copies of updated schedules to Contractor's project site file, to Subcontractors, suppliers, Architect, Owner, and other concerned parties.
- B. Include updated schedule with Application for Payments.
- C. Instruct recipients to promptly report, in writing, problems anticipated by projections shown in schedules.

END OF SECTION

SECTION 02 41 00
DEMOLITION**PART 1 GENERAL****1.01 SECTION INCLUDES**

- A. Selective demolition of building elements for alteration purposes.

1.02 SUBMITTALS

- a. Project Record Documents: Accurately record actual locations of capped and active utilities and subsurface construction.

PART 3 EXECUTION**2.01 SCOPE**

- A. Remove portions of existing buildings as indicated on the drawings.

2.02 GENERAL PROCEDURES AND PROJECT CONDITIONS

- A. Comply with applicable codes and regulations for demolition operations and safety of adjacent structures and the public.
 - 1. Obtain required permits.
 - 2. Take precautions to prevent catastrophic or uncontrolled collapse of structures to be removed; do not allow worker or public access within range of potential collapse of unstable structures.
 - 3. Provide, erect, and maintain temporary barriers and security devices.
 - 4. Use physical barriers to prevent access to areas that could be hazardous to workers or the public.
 - 5. Conduct operations to minimize effects on and interference with adjacent structures and occupants.
 - 6. Do not close or obstruct roadways or sidewalks without permit.
 - 7. Conduct operations to minimize obstruction of public and private entrances and exits; do not obstruct required exits at any time; protect persons using entrances and exits from removal operations.
- B. Do not begin removal until receipt of notification to proceed from Owner.
- C. Protect existing structures and other elements that are not to be removed.
 - 1. Provide bracing and shoring.
 - 2. Prevent movement or settlement of adjacent structures.
 - 3. Stop work immediately if adjacent structures appear to be in danger.
- D. If hazardous materials are discovered during removal operations, stop work and notify Architect and Owner; hazardous materials include regulated asbestos containing materials, lead, PCB's, and mercury.
- E. Perform demolition in a manner that maximizes salvage and recycling of materials.
 - 1. Dismantle existing construction and separate materials.
 - 2. Set aside reusable, recyclable, and salvageable materials; store and deliver to collection point or point of reuse.

2.03 EXISTING UTILITIES

- A. Coordinate work with utility companies; notify before starting work and comply with their requirements; obtain required permits.
- B. Protect existing utilities to remain from damage.
- C. Do not disrupt public utilities without permit from authority having jurisdiction.
- D. Do not close, shut off, or disrupt existing life safety systems that are in use without at least 7 days prior written notification to Owner.
- E. Do not close, shut off, or disrupt existing utility branches or take-offs that are in use without at least 3 days prior written notification to Owner.

- F. Locate and mark utilities to remain; mark using highly visible tags or flags, with identification of utility type; protect from damage due to subsequent construction, using substantial barricades if necessary.
- G. Remove exposed piping, valves, meters, equipment, supports, and foundations of disconnected and abandoned utilities.

2.04 SELECTIVE DEMOLITION FOR ALTERATIONS

- A. Drawings showing existing construction and utilities are based on casual field observation and existing record documents only.
 - 1. Verify that construction and utility arrangements are as indicated.
 - 2. Report discrepancies to Architect before disturbing existing installation.
 - 3. Beginning of demolition work constitutes acceptance of existing conditions that would be apparent upon examination prior to starting demolition.
- B. Separate areas in which demolition is being conducted from other areas that are still occupied.
 - 1. Provide, erect, and maintain temporary dustproof partitions of construction between existing areas to remain and demolition areas .
- C. Maintain weatherproof exterior building enclosure except for interruptions required for replacement or modifications; take care to prevent water and humidity damage.
- D. Remove existing work as indicated and as required to accomplish new work.
 - 1. Remove items indicated on drawings.
- E. Protect existing work to remain.
 - 1. Prevent movement of structure; provide shoring and bracing if necessary.
 - 2. Perform cutting to accomplish removals neatly and as specified for cutting new work.
 - 3. Repair adjacent construction and finishes damaged during removal work.
 - 4. Patch as specified for patching new work.

2.05 DEBRIS AND WASTE REMOVAL

- A. Remove debris, junk, and trash from site.
- B. Leave site in clean condition, ready for subsequent work.
- C. Clean up spillage and wind-blown debris from public and private lands.

END OF SECTION

**SECTION 06 10 00
ROUGH CARPENTRY****PART 1 GENERAL****1.01 SECTION INCLUDES**

- A. Rough opening framing for doors, windows, and roof openings.
- B. Concealed wood blocking, nailers, and supports.

1.02 REFERENCE STANDARDS

- A. ASTM A153/A153M - Standard Specification for Zinc Coating (Hot-Dip) on Iron and Steel Hardware; 2009.
- B. ASTM E84 - Standard Test Method for Surface Burning Characteristics of Building Materials; 2013a.
- C. AWPA U1 - Use Category System: User Specification for Treated Wood; American Wood Protection Association; 2012.
- D. PS 20 - American Softwood Lumber Standard; National Institute of Standards and Technology, Department of Commerce; 2010.

1.03 DELIVERY, STORAGE, AND HANDLING

- A. General: Cover wood products to protect against moisture. Support stacked products to prevent deformation and to allow air circulation.

PART 2 PRODUCTS**2.01 GENERAL REQUIREMENTS**

- A. Dimension Lumber: Comply with PS 20 and requirements of specified grading agencies.
 - 1. If no species is specified, provide any species graded by the agency specified; if no grading agency is specified, provide lumber graded by any grading agency meeting the specified requirements.
 - 2. Grading Agency: Any grading agency whose rules are approved by the Board of Review, American Lumber Standard Committee (www.alsc.org) and who provides grading service for the species and grade specified; provide lumber stamped with grade mark unless otherwise indicated.
- B. Lumber fabricated from old growth timber is not permitted.

2.02 DIMENSION LUMBER FOR CONCEALED APPLICATIONS

- A. Sizes: Nominal sizes as indicated on drawings, S4S.
- B. Moisture Content: S-dry or MC19.
- C. Miscellaneous Framing, Blocking, Nailers, Grounds, and Furring:
 - 1. Lumber: S4S, No. 2 or Standard Grade.
 - 2. Boards: Standard or No. 3.

2.03 ACCESSORIES

- A. Fasteners and Anchors:
 - 1. Metal and Finish: Hot-dipped galvanized steel per ASTM A 153/A 153M for high humidity and preservative-treated wood locations, unfinished steel elsewhere.

PART 3 EXECUTION**3.01 INSTALLATION - GENERAL**

- A. Select material sizes to minimize waste.
- B. Reuse scrap to the greatest extent possible; clearly separate scrap for use on site as accessory components, including: shims, bracing, and blocking.
- C. Where treated wood is used on interior, provide temporary ventilation during and immediately after installation sufficient to remove indoor air contaminants.

3.02 BLOCKING, NAILERS, AND SUPPORTS

- A. Provide framing and blocking members as indicated or as required to support finishes, fixtures, specialty items, and trim.
- B. In framed assemblies that have concealed spaces, provide solid wood fireblocking as required by applicable local code, to close concealed draft openings between floors and between top story and roof/attic space; other material acceptable to code authorities may be used in lieu of solid wood blocking.
- C. In metal stud walls, provide continuous blocking around door and window openings for anchorage of frames, securely attached to stud framing.
- D. In walls, provide blocking attached to studs as backing and support for wall-mounted items, unless item can be securely fastened to two or more studs or other method of support is explicitly indicated.
- E. Where ceiling-mounting is indicated, provide blocking and supplementary supports above ceiling, unless other method of support is explicitly indicated.

3.03 TOLERANCES

- A. Framing Members: 1/4 inch from true position, maximum.
- B. Variation from Plane (Other than Floors): 1/4 inch in 10 feet maximum, and 1/4 inch in 30 feet maximum.

END OF SECTION

SECTION 06 20 00
FINISH CARPENTRY**PART 1 GENERAL****101 SECTION INCLUDES**

- A. Finish carpentry items.
- B. Wood casings and moldings.

102 RELATED REQUIREMENTS

- A. Section 09 90 00 - Painting and Coatings: Painting and finishing of finish carpentry items.

103 REFERENCE STANDARDS

- A. AWI/AWMAC/WI (AWS) - Architectural Woodwork Standards; 2014.
- B. AWMAC/WI (NAAWS) - North American Architectural Woodwork Standards, U.S. Version 3.0; 2016.

104 SUBMITTALS

- A. See Section 01 30 00 - Administrative Requirements for submittal procedures.
- B. Shop Drawings: Indicate materials, component profiles, fastening methods, jointing details, and accessories.
 - 1. Scale of Drawings: 1-1/2 inch to 1 foot, minimum.
 - 2. Provide the information required by AWI/AWMAC/WI (AWS) or AWMAC/WI (NAAWS).

105 QUALITY ASSURANCE

- A. Fabricator Qualifications: Company specializing in fabricating the products specified in this section with minimum five years of documented experience.

106 DELIVERY, STORAGE, AND HANDLING

- A. Protect work from moisture damage.

PART 2 PRODUCTS**201 FINISH CARPENTRY ITEMS**

- A. Quality Standard: Custom Grade, in accordance with AWI/AWMAC/WI (AWS) or AWMAC/WI (NAAWS), unless noted otherwise.
- B. Interior Woodwork Items:
 - 1. Moldings, Bases, Casings, Sills and Miscellaneous Trim: Poplar; prepare for paint finish.

202 WOOD-BASED COMPONENTS

- A. Wood fabricated from old growth timber is not permitted.

203 FASTENINGS

- A. Adhesive for Purposes Other Than Laminate Installation: Suitable for the purpose; not containing formaldehyde or other volatile organic compounds.
- B. Fasteners: Of size and type to suit application.

204 ACCESSORIES

- A. Primer: Alkyd primer sealer.
- B. Wood Filler: Solvent base, tinted to match surface finish color.

205 FABRICATION

- A. Shop assemble work for delivery to site, permitting passage through building openings.

- B. When necessary to cut and fit on site, provide materials with ample allowance for cutting. Provide trim for scribing and site cutting.

PART 3 EXECUTION

301 EXAMINATION

- A. Verify adequacy of backing and support framing.

302 INSTALLATION

- A. Install work in accordance with AWI/AWMAC/WI (AWS) requirements for custom grade installation.
- B. Set and secure materials and components in place, plumb and level.
- C. Carefully scribe work abutting other components, with maximum gaps of 1/32 inch. Do not use additional overlay trim to conceal larger gaps.

303 PREPARATION FOR SITE FINISHING

- A. Set exposed fasteners. Apply wood filler in exposed fastener indentations. Sand work smooth.
- B. Site Finishing: See Section 09 90 00.
- C. Before installation, prime paint surfaces of items or assemblies to be in contact with cementitious materials.

304 TOLERANCES

- A. Maximum Variation from True Position: 1/16 inch.
- B. Maximum Offset from True Alignment with Abutting Materials: 1/32 inch.

END OF SECTION

SECTION 07 84 00
FIRESTOPPING**PART 1 GENERAL****SECTION INCLUDES**

- A. Firestopping systems.
- B. Firestopping of all joints and penetrations in fire-resistance rated and smoke-resistant assemblies.

RELATED REQUIREMENTS

- A. Section 09 21 16 - Gypsum Board Assemblies: Gypsum wallboard fireproofing.

REFERENCE STANDARDS

- A. ASTM E814 - Standard Test Method for Fire Tests of Penetration Firestop Systems; 2013a.
- B. ASTM E1966 - Standard Test Method for Fire Resistive Joint Systems; 2007 (Reapproved 2011).
- C. ASTM E2307 - Standard Test Method for Determining Fire Resistance of Perimeter Fire Barriers Using Intermediate-Scale, Multi-story Test Apparatus; 2010.
- D. ASTM E2837 - Standard Test Method for Determining Fire Resistance of Continuity Head-of-Wall Joint Systems Installed Between Rated Wall Assemblies and Nonrated Horizontal Assemblies; 2011.
- E. SCAQMD 1168 - South Coast Air Quality Management District Rule No.1168; current edition; www.aqmd.gov.
- F. UL 2079 - Standard for Tests for Fire Resistance of Building Joint Systems; Underwriters Laboratories Inc.; 2004.
- G. UL (FRD) - Fire Resistance Directory; Underwriters Laboratories Inc.; current edition.

SUBMITTALS

- A. See Section 01 30 00 - Administrative Requirements, for submittal procedures.
- B. Schedule of Firestopping: List each type of penetration, fire rating of the penetrated assembly, and firestopping test or design number.
- C. Product Data: Provide data on product characteristics, performance ratings, and limitations.
- D. Manufacturer's Installation Instructions: Indicate preparation and installation instructions.

FIELD CONDITIONS

- A. Comply with firestopping manufacturer's recommendations for temperature and conditions during and after installation. Maintain minimum temperature before, during, and for 3 days after installation of materials.

PART 2 PRODUCTS**FIRESTOPPING - GENERAL REQUIREMENTS**

- A. Firestopping: Any material meeting requirements.
- B. Firestopping Materials with Volatile Content: Provide only products having lower volatile organic compound (VOC) content than required by South Coast Air Quality Management District Rule No.1168.
- C. Primers, Sleeves, Forms, Insulation, Packing, Stuffing, and Accessories: Type required for tested assembly design.
- D. Fire Ratings: See Drawings for required wall ratings.

FIRESTOPPING ASSEMBLY REQUIREMENTS

- A. Perimeter Fire Containment Firestopping: Use any system that has been tested according to ASTM E2307 to have fire resistance F Rating equal to required fire rating of the floor assembly.

- B. Head-of-Wall Firestopping at Joints Between Non-Rated Floor and Fire-Rated Wall: Use any system that has been tested according to ASTM E2837 to have fire resistance F Rating equal to required fire rating of floor or wall, whichever is greater.
- C. Floor-to-Floor, Wall-to-Wall, and Wall-to-Floor Joints, Except Perimeter, Where Both Are Fire-Rated: Use any system that has been tested according to ASTM E1966 or UL 2079 to have fire resistance F Rating equal to required fire rating of the assembly in which the joint occurs.
- D. Through Penetration Firestopping: Use any system that has been tested according to ASTM E814 to have fire resistance F Rating equal to required fire rating of penetrated assembly.

FIRESTOPPING SYSTEMS

- A. Firestopping: Any material meeting requirements.
 - 1. Fire Ratings: Use any system listed by UL or tested in accordance with ASTM E814 that has F Rating equal to fire rating of penetrated assembly and T Rating Equal to F Rating and that meets all other specified requirements.

PART 3 EXECUTION**EXAMINATION**

- A. Verify openings are ready to receive the work of this section.

PREPARATION

- A. Clean substrate surfaces of dirt, dust, grease, oil, loose material, or other matter that could adversely affect bond of firestopping material.
- B. Remove incompatible materials that could adversely affect bond.

INSTALLATION

- A. Install materials in manner described in fire test report and in accordance with manufacturer's instructions, completely closing openings.

CLEANING

- A. Clean adjacent surfaces of firestopping materials.

PROTECTION

- A. Protect adjacent surfaces from damage by material installation.

END OF SECTION

SECTION 07 90 05
JOINT SEALERS**PART 1 GENERAL****1.01 SECTION INCLUDES**

- A. Sealants and joint backing.

1.02 REFERENCE STANDARDS

- A. ASTM C834 - Standard Specification for Latex Sealants; 2014.
- B. ASTM C920 - Standard Specification for Elastomeric Joint Sealants; 2014.
- C. ASTM C1193 - Standard Guide for Use of Joint Sealants; 2013.

1.03 ADMINISTRATIVE REQUIREMENTS

- A. Coordinate the work with other sections referencing this section.

1.04 SUBMITTALS

- A. See Section 01 30 00 - Administrative Requirements, for submittal procedures.
- B. Product Data: Provide data indicating sealant chemical characteristics, performance criteria, and substrate preparation.
- C. Manufacturer's Installation Instructions: Indicate surface preparation.

1.05 QUALITY ASSURANCE

- A. Manufacturer Qualifications: Company specializing in manufacturing the Products specified in this section with minimum three years documented experience.

1.06 FIELD CONDITIONS

- A. Maintain temperature and humidity recommended by the sealant manufacturer during and after installation.

1.07 WARRANTY

- A. See Section 01 78 00 - Closeout Submittals, for additional warranty requirements.
- B. Correct defective work within a five year period after Date of Substantial Completion.
- C. Warranty: Include coverage for installed sealants and accessories which fail to achieve airtight seal, exhibit loss of adhesion or cohesion, or do not cure.

PART 2 PRODUCTS**2.01 SEALANTS**

- A. General Purpose Exterior Sealant: Polyurethane; ASTM C920, Grade NS, Class 25 minimum; Uses M, G, and A; single component.
 - 1. Color: Match adjacent finished surfaces.
- B. Exterior Metal Lap Joint Sealant: Butyl or polyisobutylene, nondrying, nonskinning, noncuring.
 - 1. Applications: Use for:
 - a. Concealed sealant bead in sheet metal work.
 - b. Concealed sealant bead in siding overlaps.
- C. General Purpose Interior Sealant: Acrylic emulsion latex; ASTM C834, Type OP, Grade NF single component, paintable.
 - 1. Color: Match adjacent finished surfaces.

2.02 ACCESSORIES

- A. Primer: Non-staining type, recommended by sealant manufacturer to suit application.
- B. Joint Cleaner: Non-corrosive and non-staining type, recommended by sealant manufacturer; compatible with joint forming materials.
- C. Joint Backing: Round foam rod compatible with sealant; ASTM D 1667, closed cell PVC; oversized 30 to 50 percent larger than joint width.

- D. Bond Breaker: Pressure sensitive tape recommended by sealant manufacturer to suit application.

PART 3 EXECUTION

3.01 EXAMINATION

- A. Verify that substrate surfaces are ready to receive work.
- B. Verify that joint backing and release tapes are compatible with sealant.

3.02 PREPARATION

- A. Remove loose materials and foreign matter that could impair adhesion of sealant.
- B. Clean and prime joints in accordance with manufacturer's instructions.
- C. Perform preparation in accordance with manufacturer's instructions and ASTM C1193.
- D. Protect elements surrounding the work of this section from damage or disfigurement.

3.03 INSTALLATION

- A. Perform work in accordance with sealant manufacturer's requirements for preparation of surfaces and material installation instructions.
- B. Perform installation in accordance with ASTM C1193.
- C. Measure joint dimensions and size joint backers to achieve width-to-depth ratio, neck dimension, and surface bond area as recommended by manufacturer.
- D. Install bond breaker where joint backing is not used.
- E. Install sealant free of air pockets, foreign embedded matter, ridges, and sags.
- F. Apply sealant within recommended application temperature ranges. Consult manufacturer when sealant cannot be applied within these temperature ranges.
- G. Tool joints concave.

3.04 CLEANING

- A. Clean adjacent soiled surfaces.

3.05 PROTECTION

- A. Protect sealants until cured.

END OF SECTION

SECTION 08 11 13
HOLLOW METAL FRAMES**PART 1 GENERAL****1.01 SECTION INCLUDES**

- A. Non-fire-rated and fire rated hollow metal frames.

1.02 RELATED REQUIREMENTS

- A. Section 08 71 00 - DOOR HARDWARE.
- B. Section 09 90 00 - Painting and Coating: Field painting.

1.03 REFERENCE STANDARDS

- A. ANSI/SDI A250.4 - Test Procedure and Acceptance Criteria for Physical Endurance for Steel Doors, Frames and Frame Anchors; 2011.
- B. ANSI/SDI A250.8 - Specifications for Standard Steel Doors and Frames (SDI-100); 2014.
- C. ANSI/SDI A250.10 - Test Procedure and Acceptance Criteria for Prime Painted Steel Surfaces for Steel Doors and Frames; 2011.
- D. ASTM A653/A653M - Standard Specification for Steel Sheet, Zinc-Coated (Galvanized) or Zinc-Iron Alloy-Coated (Galvannealed) by the Hot-Dip Process; 2015.
- E. ASTM A1008/A1008M - Standard Specification for Steel, Sheet, Cold-Rolled, Carbon, Structural, High-Strength, Low Alloy, and High-Strength Low-Alloy with Improved Formability, Solution Hardened, and Bake Hardenable; 2015.
- F. ASTM A1011/A1011M - Standard Specification for Steel, Sheet and Strip, Hot-Rolled, Carbon, Structural, High-Strength Low-Alloy, High-Strength Low-Alloy with Improved Formability, and Ultra-High Strength; 2014.
- G. NAAMM HMMA 840 - Guide Specifications for Installation and Storage of Hollow Metal Doors and Frames; 2007.

1.04 SUBMITTALS

- A. Product Data: Materials and details of design and construction, hardware locations, reinforcement type and locations, anchorage and fastening methods, and finishes; and one copy of referenced standards/guidelines.
- B. Shop Drawings: Details of each opening, showing elevations, frame profiles, and any indicated finish requirements.
- C. Installation Instructions: Manufacturer's published instructions, including any special installation instructions relating to this project.

1.05 QUALITY ASSURANCE

- A. Manufacturer Qualifications: Company specializing in manufacturing the products specified in this section with minimum three years documented experience.
- B. Copies of Documents at Project Site: Maintain at the project site a copy of each referenced document that prescribes installation requirements.

1.06 DELIVERY, STORAGE, AND HANDLING

- A. Comply with NAAMM HMMA 840 or ANSI/SDI A250.8 (SDI-100) in accordance with specified requirements.
- B. Protect with resilient packaging; avoid humidity build-up under coverings; prevent corrosion and adverse effects on factory applied painted finish.

PART 2 PRODUCTS**2.01 FRAMES**

- A. Requirements for All Frames:
 - 1. Steel used for fabrication of doors and frames shall comply with one or more of the following requirements; Galvannealed steel conforming to ASTM A653/A653M, cold-rolled steel conforming to ASTM A1008/A1008M, or hot-rolled pickled and oiled (HRPO) steel conforming to ASTM A1011/A1011M, Commercial Steel (CS) Type B for each.
 - 2. Finish: Factory primed, for field finishing.
 - 3. Fire-Rated Assemblies: Assemblies complying with NFPA 80 that are listed and labeled by a qualified testing agency acceptable to authorities having jurisdiction for fire-protection ratings indicated on Drawings, based on testing at positive pressure according to NFPA 252 or UL 10C.

2.02 HOLLOW METAL FRAMES

- A. Comply with standards and/or custom guidelines as indicated for corresponding door in accordance with applicable door frame requirements.
- B. General:
 - 1. Finish: Factory primed, for field finishing.
- C. Exterior Door Frames: Full profile/continuously welded type.
 - 1. Weatherstripping: Separate, see Section 08 71 00.
- D. Frames for Wood Doors: Comply with frame requirements in accordance with corresponding door.

2.04 ACCESSORIES

- A. Silencers: Resilient rubber, fitted into drilled hole; 3 on strike side of single door, 3 on center mullion of pairs, and 2 on head of pairs without center mullions.
- B. Temporary Frame Spreaders: Provide for factory- or shop-assembled frames.

2.05 FINISHES

- A. Primer: Rust-inhibiting, complying with ANSI/SDI A250.10, door manufacturer's standard.

PART 3 EXECUTION**3.01 EXAMINATION**

- A. Verify existing conditions before starting work.
- B. Verify that opening sizes and tolerances are acceptable.
- C. Verify that finished walls are in plane to ensure proper door alignment.

3.02 INSTALLATION

- A. Install doors and frames in accordance with manufacturer's instructions and related requirements of specified door and frame standards or custom guidelines indicated.
- B. Coordinate frame anchor placement with wall construction.
- C. Coordinate installation of hardware.

3.03 TOLERANCES

- A. Clearances Between Door and Frame: Comply with related requirements of specified door and frame standards or custom guidelines indicated.
- B. Maximum Diagonal Distortion: 1/16 in measured with straight edge, corner to corner.

3.04 ADJUSTING

- A. Adjust for smooth and balanced door movement.

END OF SECTION

SECTION 08 43 13
ALUMINUM-FRAMED STOREFRONTS**PART 1 GENERAL****1.01 SECTION INCLUDES**

- A. Aluminum-framed storefront, with vision glass.
- B. Aluminum doors and frames.

1.02 RELATED REQUIREMENTS

- A. Section 07 92 00 - Joint Sealants: Sealing joints between frames and adjacent construction.
- B. Section 08 80 00 - Glazing: Glass and glazing accessories.

1.03 REFERENCE STANDARDS

- A. AAMA CW-10 - Care and Handling of Architectural Aluminum from Shop to Site; 2015.
- B. AAMA 611 - Voluntary Specification for Anodized Architectural Aluminum; 2012.
- C. ASTM B221 - Standard Specification for Aluminum and Aluminum-Alloy Extruded Bars, Rods, Wire, Profiles, and Tubes; 2014.
- D. ASTM B221M - Standard Specification for Aluminum and Aluminum-Alloy Extruded Bars, Rods, Wire, Profiles, and Tubes [Metric]; 2013.

1.04 ADMINISTRATIVE REQUIREMENTS

- A. Coordinate with installation of other components that comprise the exterior enclosure.

1.05 SUBMITTALS

- A. See Section 01 30 00 - Administrative Requirements, for submittal procedures.
- B. Product Data: Provide component dimensions, describe components within assembly, anchorage and fasteners, glass and infill, internal drainage details.
- C. Shop Drawings: Indicate system dimensions, framed opening requirements and tolerances, affected related Work, attachment requirements to meet IBC wind load requirements, expansion and contraction joint location and details, and field welding required.
- D. Manufacturer's Certificate: Certify that the products supplied meet or exceed the specified requirements.
- E. Warranty: Submit manufacturer warranty and ensure forms have been completed in Owner's name and registered with manufacturer.

1.06 QUALITY ASSURANCE

- A. Manufacturer Qualifications: Company specializing in performing work of type specified and with at least 5 years of documented experience.
- B. Installer Qualifications: Company specializing in performing work of type specified and with at least three years of experience.

1.07 DELIVERY, STORAGE, AND HANDLING

- A. Handle products of this section in accordance with AAMA CW-10.
- B. Protect finished aluminum surfaces with wrapping. Do not use adhesive papers or sprayed coatings that bond to aluminum when exposed to sunlight or weather.

1.08 WARRANTY

- A. See Section 01 78 00 - Closeout Submittals, for additional warranty requirements.
- B. Correct defective Work within a five year period after Date of Substantial Completion.
- C. Provide five-year manufacturer warranty against excessive degradation of exterior finish. Include provision for replacement of units with excessive fading, chalking, or flaking.

PART 2 PRODUCTS**2.01 MANUFACTURERS**

- A. Aluminum-Framed Storefront and Doors:
 - 1. Kawneer North America: www.kawneer.com.
 - 2. Oldcastle BuildingEnvelope: www.oldcastlebe.com.

3. YKK AP America Inc: www.ykkap.com.
4. Substitutions: See Section 01 60 00 - Product Requirements.

2.02 STOREFRONT

- A. Aluminum-Framed Storefront: Factory fabricated, factory finished aluminum framing members with infill, and related flashings, anchorage and attachment devices.
 1. Glazing Position: Centered (front to back).
 2. Vertical Mullion Dimensions: Size required to meet wind load required by IBC 2018.
 3. Finish: Class I color anodized.
 - a. Factory finish all surfaces that will be exposed in completed assemblies.
 4. Finish Color: Color noted on the drawings.
 5. Fabrication: Joints and corners flush, hairline, and weatherproof, accurately fitted and secured; prepared to receive anchors and hardware; fasteners and attachments concealed from view; reinforced as required for imposed loads.
 6. Construction: Eliminate noises caused by wind and thermal movement, prevent vibration harmonics, and prevent "stack effect" in internal spaces.
 7. System Internal Drainage: Drain to the exterior by means of a weep drainage network any water entering joints, condensation occurring in glazing channel, and migrating moisture occurring within system.
 8. Expansion/Contraction: Provide for expansion and contraction within system components caused by cycling temperature range of 170 degrees F over a 12 hour period without causing detrimental effect to system components, anchorages, and other building elements.
 9. Movement: Allow for movement between storefront and adjacent construction, without damage to components or deterioration of seals.
 10. Perimeter Clearance: Minimize space between framing members and adjacent construction while allowing expected movement.

2.03 COMPONENTS

- A. Aluminum Framing Members: Tubular aluminum sections, thermally broken with interior section insulated from exterior, drainage holes and internal weep drainage system.
 1. Glazing Stops: Flush.
- B. Glazing: As specified in Section 08 80 00.
- C. Swing Doors: Glazed aluminum.
 1. Thickness: 1-3/4 inches.
 2. Top Rail: 5 inches minimum wide.
 3. Vertical Stiles: 5 inches minimum wide.
 4. Bottom Rail: 10 inches minimum wide.
 5. Finish: Same as storefront.

2.04 MATERIALS

- A. Extruded Aluminum: ASTM B221 (ASTM B221M).
- B. Fasteners: Stainless steel.
- C. Exposed Flashings and Column Covers: Aluminum sheet, 20 gage, 0.032 inch minimum thickness; finish to match framing members.
- D. Glazing Gaskets: Type to suit application to achieve weather, moisture, and air infiltration requirements.

2.05 FINISHES

- A. Class I Color Anodized Finish: AAMA 611 AA-M12C22A42 Integrally colored anodic coating not less than 0.7 mils thick.

2.06 HARDWARE

- A. See Hardware Schedule.

PART 3 EXECUTION**3.01 EXAMINATION**

- A. Verify dimensions, tolerances, and method of attachment with other work.
- B. Verify that wall openings and adjoining air and vapor seal materials are ready to receive work of this section.

3.02 INSTALLATION

- A. Install wall system in accordance with manufacturer's instructions.
- B. Attach to structure to permit sufficient adjustment to accommodate construction tolerances and other irregularities.
- C. Provide alignment attachments and shims to permanently fasten system to building structure.
- D. Align assembly plumb and level, free of warp or twist. Maintain assembly dimensional tolerances, aligning with adjacent work.
- E. Touch-up minor damage to factory applied finish; replace components that cannot be satisfactorily repaired.

3.03 TOLERANCES

- A. Maximum Variation from Plumb: 0.06 inches every 3 ft non-cumulative or 1/16 inches per 10 ft, whichever is less.
- B. Maximum Misalignment of Two Adjoining Members Abutting in Plane: 1/32 inch.

3.04 ADJUSTING

- A. Adjust operating hardware and sash for smooth operation.

3.05 CLEANING

- A. Remove protective material from pre-finished aluminum surfaces.
- B. Wash down surfaces with a solution of mild detergent in warm water, applied with soft, clean wiping cloths. Take care to remove dirt from corners. Wipe surfaces clean.

3.06 PROTECTION

- A. Protect installed products from damage until Date of Substantial Completion.

END OF SECTION

SECTION 08 71 00
DOOR HARDWARE**PART 1 - GENERAL****1.01 SUMMARY**

- A. Section includes:
 - 1. Mechanical and electrified door hardware
 - 2. Electronic access control system components
 - 3. Field verification, preparation and modification of existing doors and frames to receive new door hardware.
- B. Section excludes:
 - 1. Windows
 - 2. Cabinets (casework), including locks in cabinets
 - 3. Signage
 - 4. Toilet accessories
 - 5. Overhead doors
- C. Related Sections:
 - 1. Division 01 Section "Alternates" for alternates affecting this section.
 - 2. Division 06 Section "Rough Carpentry"
 - 3. Division 06 Section "Finish Carpentry"
 - 4. Division 07 Section "Joint Sealants" for sealant requirements applicable to threshold installation specified in this section.
 - 5. Division 08 Sections:
 - a. "Metal Doors and Frames"
 - b. "Flush Wood Doors"
 - c. "Stile and Rail Wood Doors"
 - d. "Interior Aluminum Doors and Frames"
 - e. "Aluminum-Framed Entrances and Storefronts"
 - f. "Stainless Steel Doors and Frames"
 - g. "Special Function Doors"
 - h. "Entrances"
 - 6. Division 09 sections for touchup, finishing or refinishing of existing openings modified by this section.
 - 7. Division 26 "Electrical" sections for connections to electrical power system and for low-voltage wiring.
 - 8. Division 28 "Electronic Safety and Security" sections for coordination with other components of electronic access control system and fire alarm system.

1.02 REFERENCES

- A. UL LLC
 - 1. UL 10B - Fire Test of Door Assemblies
 - 2. UL 10C - Positive Pressure Test of Fire Door Assemblies
 - 3. UL 1784 - Air Leakage Tests of Door Assemblies
 - 4. UL 305 - Panic Hardware
- B. DHI - Door and Hardware Institute
 - 1. Sequence and Format for the Hardware Schedule
 - 2. Recommended Locations for Builders Hardware
 - 3. Keying Systems and Nomenclature
 - 4. Installation Guide for Doors and Hardware
- C. NFPA – National Fire Protection Association
 - 1. NFPA 70 – National Electric Code
 - 2. NFPA 80 – 2016 Edition – Standard for Fire Doors and Other Opening Protectives
 - 3. NFPA 101 – Life Safety Code
 - 4. NFPA 105 – Smoke and Draft Control Door Assemblies
 - 5. NFPA 252 – Fire Tests of Door Assemblies

- D. ANSI - American National Standards Institute
 - 1. ANSI A117.1 – 2017 Edition – Accessible and Usable Buildings and Facilities
 - 2. ANSI/BHMA A156.1 - A156.29, and ANSI/BHMA A156.31 - Standards for Hardware and Specialties
 - 3. ANSI/BHMA A156.28 - Recommended Practices for Keying Systems
 - 4. ANSI/WDMA I.S. 1A - Interior Architectural Wood Flush Doors
 - 5. ANSI/SDI A250.8 - Standard Steel Doors and Frames

1.03 SUBMITTALS

- A. General:
 - 1. Submit in accordance with Conditions of Contract and Division 01 Submittal Procedures.
 - 2. Prior to forwarding submittal:
 - a. Comply with procedures for verifying existing door and frame compatibility for new hardware, as specified in PART 3, "EXAMINATION" article, herein.
 - b. Review drawings and Sections from related trades to verify compatibility with specified hardware.
 - c. Highlight, encircle, or otherwise specifically identify on submittals: deviations from Contract Documents, issues of incompatibility or other issues which may detrimentally affect the Work.
- B. Action Submittals:
 - 1. Product Data: Submit technical product data for each item of door hardware, installation instructions, maintenance of operating parts and finish, and other information necessary to show compliance with requirements.
 - 2. Riser and Wiring Diagrams: After final approval of hardware schedule, submit details of electrified door hardware, indicating:
 - a. Wiring Diagrams: For power, signal, and control wiring and including:
 - 1) Details of interface of electrified door hardware and building safety and security systems.
 - 2) Schematic diagram of systems that interface with electrified door hardware.
 - 3) Point-to-point wiring.
 - 4) Risers.
 - 3. Samples for Verification: If requested by Architect, submit production sample of requested door hardware unit in finish indicated and tagged with full description for coordination with schedule.
 - a. Samples will be returned to supplier. Units that are acceptable to Architect may, after final check of operations, be incorporated into Work, within limitations of key coordination requirements.
 - 4. Door Hardware Schedule:
 - a. Submit concurrent with submissions of Product Data, Samples, and Shop Drawings. Coordinate submission of door hardware schedule with scheduling requirements of other work to facilitate fabrication of other work critical in Project construction schedule.
 - b. Submit under direct supervision of a Door Hardware Institute (DHI) certified Architectural Hardware Consultant (AHC) or Door Hardware Consultant (DHC) with hardware sets in vertical format as illustrated by Sequence of Format for the Hardware Schedule published by DHI.
 - c. Indicate complete designations of each item required for each opening, include:
 - 1) Door Index: door number, heading number, and Architect's hardware set number.
 - 2) Quantity, type, style, function, size, and finish of each hardware item.
 - 3) Name and manufacturer of each item.
 - 4) Fastenings and other pertinent information.
 - 5) Location of each hardware set cross-referenced to indications on Drawings.
 - 6) Explanation of all abbreviations, symbols, and codes contained in schedule.
 - 7) Mounting locations for hardware.
 - 8) Door and frame sizes and materials.
 - 9) Degree of door swing and handing.

- 10) Operational Description of openings with electrified hardware covering egress, ingress (access), and fire/smoke alarm connections.
5. Key Schedule:
 - a. After Keying Conference, provide keying schedule that includes levels of keying, explanations of key system's function, key symbols used, and door numbers controlled.
 - b. Use ANSI/BHMA A156.28 "Recommended Practices for Keying Systems" as guideline for nomenclature, definitions, and approach for selecting optimal keying system.
 - c. Provide 3 copies of keying schedule for review prepared and detailed in accordance with referenced DHI publication. Include schematic keying diagram and index each key to unique door designations.
 - d. Index keying schedule by door number, keyset, hardware heading number, cross keying instructions, and special key stamping instructions.
 - e. Provide one complete bitting list of key cuts and one key system schematic illustrating system usage and expansion. Forward bitting list, key cuts and key system schematic directly to Owner, by means as directed by Owner.
 - f. Prepare key schedule by or under supervision of supplier, detailing Owner's final keying instructions for locks.
- C. Informational Submittals:
 1. Provide Qualification Data for Supplier, Installer and Architectural Hardware Consultant.
 2. Provide Product Data:
 - a. Certify that door hardware approved for use on types and sizes of labeled fire-rated doors complies with listed fire-rated door assemblies.
 - b. Include warranties for specified door hardware.
- D. Closeout Submittals:
 1. Operations and Maintenance Data: Provide in accordance with Division 01 and include:
 - a. Complete information on care, maintenance, and adjustment; data on repair and replacement parts, and information on preservation of finishes.
 - b. Catalog pages for each product.
 - c. Final approved hardware schedule edited to reflect conditions as installed.
 - d. Final keying schedule
 - e. Copy of warranties including appropriate reference numbers for manufacturers to identify project.
 - f. As-installed wiring diagrams for each opening connected to power, both low voltage and 110 volts.
- E. Inspection and Testing:
 1. Submit written reports to the Owner and Authority Having Jurisdiction (AHJ) of the results of functional testing and inspection for:
 - a. Fire door assemblies, in compliance with NFPA 80.
 - b. Required egress door assemblies, in compliance with NFPA 101.

1.04 QUALITY ASSURANCE

- A. Qualifications and Responsibilities:
 1. Supplier: Recognized architectural hardware supplier with a minimum of 5 years documented experience supplying both mechanical and electromechanical door hardware similar in quantity, type, and quality to that indicated for this Project. Supplier to be recognized as a factory direct distributor by the manufacturer of the primary materials with a warehousing facility in the Project's vicinity. Supplier to have on staff, a certified Architectural Hardware Consultant (AHC) or Door Hardware Consultant (DHC) available to Owner, Architect, and Contractor, at reasonable times during the Work for consultation.
 2. Installer: Qualified tradesperson skilled in the application of commercial grade hardware with experience installing door hardware similar in quantity, type, and quality as indicated for this Project.

3. Architectural Hardware Consultant: Person who is experienced in providing consulting services for door hardware installations that are comparable in material, design, and extent to that indicated for this Project and meets these requirements:
 - a. For door hardware: DHI certified AHC or DHC.
 - b. Can provide installation and technical data to Architect and other related subcontractors.
 - c. Can inspect and verify components are in working order upon completion of installation.
 - d. Capable of producing wiring diagram and coordinating installation of electrified hardware with Architect and electrical engineers.
 4. Single Source Responsibility: Obtain each type of door hardware from single manufacturer.
- B. Certifications:
1. Fire-Rated Door Openings:
 - a. Provide door hardware for fire-rated openings that complies with NFPA 80 and requirements of authorities having jurisdiction.
 - b. Provide only items of door hardware that are listed products tested by UL LLC, Intertek Testing Services, or other testing and inspecting organizations acceptable to authorities having jurisdiction for use on types and sizes of doors indicated, based on testing at positive pressure and according to NFPA 252 or UL 10C and in compliance with requirements of fire-rated door and door frame labels.
 2. Smoke and Draft Control Door Assemblies:
 - a. Provide door hardware that meets requirements of assemblies tested according to UL 1784 and installed in compliance with NFPA 105
 - b. Comply with the maximum air leakage of 0.3 cfm/sq. ft. (3 cu. m per minute/sq. m) at tested pressure differential of 0.3-inch wg (75 Pa) of water.
 3. Electrified Door Hardware
 - a. Listed and labeled as defined in NFPA 70, Article 100, by testing agency acceptable to authorities having jurisdiction.
 4. Accessibility Requirements:
 - a. Comply with governing accessibility regulations cited in "REFERENCES" article 087100, 1.02.D3 herein for door hardware on doors in an accessible route. This project must comply with all Federal Americans with Disability Act regulations and all Local Accessibility Regulations.
- C. Pre-Installation Meetings
1. Keying Conference
 - a. Incorporate keying conference decisions into final keying schedule after reviewing door hardware keying system including:
 - 1) Function of building, flow of traffic, purpose of each area, degree of security required, and plans for future expansion.
 - 2) Preliminary key system schematic diagram.
 - 3) Requirements for access control.
 - 4) Address for delivery of keys.
 2. Pre-installation Conference
 - a. Review and finalize construction schedule and verify availability of materials, Installer's personnel, equipment, and facilities needed to make progress and avoid delays.
 - b. Inspect and discuss preparatory work performed by other trades.
 - c. Inspect and discuss electrical roughing-in for electrified door hardware.
 - d. Review sequence of operation for each type of electrified door hardware.
 - e. Review required testing, inspecting, and certifying procedures.
 - f. Review questions or concerns related to proper installation and adjustment of door hardware.
 3. Electrified Hardware Coordination Conference:
 - a. Prior to ordering electrified hardware, schedule and hold meeting to coordinate door hardware with security, electrical, doors and frames, and other related suppliers.

1.05 DELIVERY, STORAGE, AND HANDLING

- A. Inventory door hardware on receipt and provide secure lock-up for hardware delivered to Project site. Promptly replace products damaged during shipping.
- B. Tag each item or package separately with identification coordinated with final door hardware schedule, and include installation instructions, templates, and necessary fasteners with each item or package. Deliver each article of hardware in manufacturer's original packaging.
- C. Maintain manufacturer-recommended environmental conditions throughout storage and installation periods.
- D. Provide secure lock-up for door hardware delivered to Project. Control handling and installation of hardware items so that completion of Work will not be delayed by hardware losses both before and after installation.
- E. Handle hardware in manner to avoid damage, marring, or scratching. Correct, replace or repair products damaged during Work. Protect products against malfunction due to paint, solvent, cleanser, or any chemical agent.
- F. Deliver keys to manufacturer of key control system for subsequent delivery to Owner.

1.06 COORDINATION

- A. Coordinate layout and installation of floor-recessed door hardware with floor construction. Cast anchoring inserts into concrete.
- B. Installation Templates: Distribute for doors, frames, and other work specified to be factory or shop prepared. Check Shop Drawings of other work to confirm that adequate provisions are made for locating and installing door hardware to comply with indicated requirements.
- C. Security: Coordinate installation of door hardware, keying, and access control with Owner's security consultant.
- D. Electrical System Roughing-In: Coordinate layout and installation of electrified door hardware with connections to power supplies and building safety and security systems.
- E. Existing Openings: Where existing doors, frames and/or hardware are to remain, field verify existing functions, conditions and preparations and coordinate to suit opening conditions and to provide proper door operation.

1.07 WARRANTY

- A. Manufacturer's standard form in which manufacturer agrees to repair or replace components of door hardware that fail in materials or workmanship within published warranty period.
 - 1. Warranty does not cover damage or faulty operation due to improper installation, improper use or abuse.
 - 2. Warranty Period: Beginning from date of Substantial Completion, for durations indicated in manufacturer's published listings.
 - a. Mechanical Warranty
 - 1) Locks
 - a) Falcon: 10 years
 - 2) Exit Devices
 - a) Falcon: 10 years
 - 3) Closers
 - a) Falcon SC Series: 10 years

1.08 MAINTENANCE

- A. Furnish complete set of special tools required for maintenance and adjustment of hardware, including changing of cylinders.
- B. Turn over unused materials to Owner for maintenance purposes.

PART 2 - PRODUCTS**2.01 MANUFACTURERS**

- A. Approval of manufacturers and/or products other than those listed as "Scheduled Manufacturer" or "Acceptable Manufacturers" in the individual article for the product category shall be in accordance with QUALITY ASSURANCE article, herein.

- B. Approval of products from manufacturers indicated in "Acceptable Manufacturers" is contingent upon those products providing all functions and features and meeting all requirements of scheduled manufacturer's product.
- C. Where specified hardware is not adaptable to finished shape or size of members requiring hardware, furnish suitable types having same operation and quality as type specified, subject to Architect's approval.

2.02 MATERIALS

- A. Fabrication
 - 1. Provide door hardware manufactured to comply with published templates generally prepared for machine, wood, and sheet metal screws. provide screws according to manufacturer's recognized installation standards for application intended.
 - 2. Finish exposed screws to match hardware finish, or, if exposed in surfaces of other work, to match finish of this other work including prepared for paint surfaces to receive painted finish.
 - 3. Provide concealed fasteners wherever possible for hardware units exposed when door is closed. Coordinate with "Metal Doors and Frames", "Flush Wood Doors", "Stile and Rail Wood Doors" to ensure proper reinforcements. Advise the Architect where visible fasteners, such as thru bolts, are required.
- B. Modification and Preparation of Existing Doors: Where existing door hardware is indicated to be removed and reinstalled.
 - 1. Provide necessary fillers, Dutchmen, reinforcements, and fasteners, compatible with existing materials, as required for mounting new opening hardware and to cover existing door and frame preparations.
 - 2. Use materials which match materials of adjacent modified areas.
 - 3. When modifying existing fire-rated openings, provide materials permitted by NFPA 80 as required to maintain fire-rating.
- C. Provide screws, bolts, expansion shields, drop plates and other devices necessary for hardware installation.
 - 1. Where fasteners are exposed to view: Finish to match adjacent door hardware material.
- D. Cable and Connectors:
 - 1. Where scheduled in the hardware sets, provide each item of electrified hardware and wire harnesses with number and gage of wires enough to accommodate electric function of specified hardware.
 - 2. Provide Molex connectors that plug directly into connectors from harnesses, electric locking and power transfer devices.
 - 3. Provide through-door wire harness for each electrified locking device installed in a door and wire harness for each electrified hinge, electrified continuous hinge, electrified pivot, and electric power transfer for connection to power supplies.

2.03 HINGES

- A. Manufacturers and Products:
 - 1. Scheduled Manufacturer and Product:
 - a. Ives 5BB series
 - 2. Acceptable Manufacturers and Products:
 - a. Hager BB1191/1279 series
 - b. McKinney TB series
- B. Requirements:
 - 1. Provide hinges conforming to ANSI/BHMA A156.1.
 - 2. Provide five knuckle, ball bearing hinges.
 - 3. 1-3/4 inch (44 mm) thick doors, up to and including 36 inches (914 mm) wide:
 - a. Exterior: Standard weight, bronze or stainless steel, 4-1/2 inches (114 mm) high
 - b. Interior: Standard weight, steel, 4-1/2 inches (114 mm) high
 - 4. 1-3/4 inch (44 mm) thick doors over 36 inches (914 mm) wide:
 - a. Exterior: Heavy weight, bronze/stainless steel, 5 inches (127 mm) high
 - b. Interior: Heavy weight, steel, 5 inches (127 mm) high
 - 5. Adjust hinge width for door, frame, and wall conditions to allow proper degree of opening.

6. Provide three hinges per door leaf for doors 90 inches (2286 mm) or less in height, and one additional hinge for each 30 inches (762 mm) of additional door height.
7. Where new hinges are specified for existing doors or existing frames, provide new hinges of identical size to hinge preparation present in existing door or existing frame.
8. Hinge Pins: Except as otherwise indicated, provide hinge pins as follows:
 - a. Steel Hinges: Steel pins
 - b. Non-Ferrous Hinges: Stainless steel pins
 - c. Out-Swinging Exterior Doors: Non-removable pins
 - d. Out-Swinging Interior Lockable Doors: Non-removable pins
 - e. Interior Non-lockable Doors: Non-rising pins
9. Provide hinges with electrified options as scheduled in the hardware sets. Provide with number and gage of wires enough to accommodate electric function of specified hardware. Locate electric hinge at second hinge from bottom or nearest to electrified locking component. Provide mortar guard for each electrified hinge specified.

2.04 FLUSH BOLTS

- A. Manufacturers:
 1. Scheduled Manufacturer:
 - a. Ives
 2. Acceptable Manufacturers:
 - a. Trimco
 - b. Don-Jo
 - c. Hager
- B. Requirements:
 1. Provide automatic, constant latching, and manual flush bolts with forged bronze or stainless-steel face plates, extruded brass levers, and with wrought brass guides and strikes. Provide 12 inch (305 mm) steel or brass rods at doors up to 90 inches (2286 mm) in height. For doors over 90 inches (2286 mm) in height increase top rods by 6 inches (152 mm) for each additional 6 inches (152 mm) of door height. Provide dust-proof strikes at each bottom flush bolt.

2.05 MORTISE LOCKS

- A. Manufacturers and Products:
 1. Scheduled Manufacturer and Product:
 - a. Falcon MA series
 2. Acceptable Manufacturers and Products:
 - a. Dorma ML9000 series
 - b. Schlage L Series
- B. Requirements:
 1. Provide mortise locks conforming to ANSI/BHMA A156.13 Series 1000, Grade 1, and UL Listed for 3-hour fire doors.
 2. Provide locks manufactured from heavy gauge steel, containing components of steel with a zinc dichromate plating for corrosion resistance.
 3. Provide lock case that is multi-function and field reversible for handing without opening case. Cylinders: Refer to "KEYING" article, herein.
 4. Provide locks with standard 2-3/4 inches (70 mm) backset with full 3/4 inch (19 mm) throw stainless steel mechanical anti-friction latchbolt. Provide deadbolt with full 1-inch (25 mm) throw, constructed of stainless steel.
 5. Provide standard ASA strikes unless extended lip strikes are necessary to protect trim.
 6. Provide electrified options as scheduled in the hardware sets. Where scheduled, provide a request to exit (RX) switch that is actuated with rotation of inside lever.
 7. Lever Trim: Solid brass, bronze, or stainless steel, cast or forged in design specified, with wrought roses and external lever spring cages. Provide thru-bolted levers with 2-piece spindles.
 - a. Lever Design: Dane

2.06 EXIT DEVICES

- A. Manufacturers and Products:
 - 1. Scheduled Manufacturer and Product:
 - a. Falcon 24/25 series
 - 2. Acceptable Manufacturers and Products:
 - a. Sargent 19-43-GL-80 series
 - b. Precision Apex series
- B. Requirements:
 - 1. Provide exit devices tested to ANSI/BHMA A156.3 Grade 1 and UL listed for Panic Exit or Fire Exit Hardware.
 - 2. Cylinders: Refer to "KEYING" article, herein.
 - 3. Provide touchpad type exit devices, fabricated of brass, bronze, stainless steel, or aluminum, plated to standard architectural finishes to match balance of door hardware.
 - 4. Touchpad must extend a minimum of one half of door width. No plastic inserts are allowed in touchpads.
 - 5. Provide exit devices with deadlatching feature for security and for future addition of alarm kits and/or other electrified requirements.
 - 6. Provide flush end caps for exit devices.
 - 7. Provide exit devices with manufacturer's approved strikes.
 - 8. Provide exit devices cut to door width and height. Install exit devices at height recommended by exit device manufacturer, allowable by governing building codes, and approved by Architect.
 - 9. Mount mechanism case flush on face of doors or provide spacers to fill gaps behind devices. Where glass trim or molding projects off face of door, provide glass bead kits.
 - 10. Provide cylinder or hex-key dogging as specified at non fire-rated openings.
 - 11. Provide electrified options as scheduled.
 - 12. Provide exit devices with optional trim designs to match other lever and pull designs used on the project.

2.07 CYLINDERS

- A. Manufacturers:
 - 1. Scheduled Manufacturer and Product:
 - a. AS REQUIRED TO MATCH OWNER'S EXISTING SYSTEM.
 - 2. Acceptable Manufacturers and Products:
- B. Requirements:
 - 1. Provide cylinders/cores to match Owner's existing key system, compliant with ANSI/BHMA A156.5; latest revision; cylinder face finished to match lockset, manufacturer's series as indicated. Refer to "KEYING" article, herein.

2.08 KEYING

- A. Scheduled System:
 - 1. Existing factory registered system:
 - a. Provide cylinders/cores keyed into Owner's existing factory registered keying system. Comply with guidelines in ANSI/BHMA A156.28, incorporating decisions made at keying conference.
- B. Requirements:
 - 1. Construction Keying:
 - a. Replaceable Construction Cores.
 - 1) Provide temporary construction cores replaceable by permanent cores, furnished in accordance with the following requirements.
 - a) 3 construction control keys
 - b) 12 construction change (day) keys.
 - 2) Owner or Owner's Representative will replace temporary construction cores with permanent cores.
 - 2. Permanent Keying:
 - a. Provide permanent cylinders/cores keyed by the manufacturer according to the following key system.

- 1) Master Keying system as directed by the Owner.
- b. Forward biting list and keys separately from cylinders, by means as directed by Owner. Failure to comply with forwarding requirements will be cause for replacement of cylinders/cores involved at no additional cost to Owner.
- c. Provide keys with the following features:
 - 1) Material: Nickel silver; minimum thickness of .107-inch (2.3mm)
 - 2) Patent Protection: Keys and blanks protected by one or more utility patent(s).
- d. Identification:
 - 1) Mark permanent cylinders/cores and keys with applicable blind code for identification. Do not provide blind code marks with actual key cuts.
 - 2) Identification stamping provisions must be approved by the Architect and Owner.
 - 3) Stamp cylinders/cores and keys with Owner's unique key system facility code as established by the manufacturer; key symbol and embossed or stamped with "DO NOT DUPLICATE" along with the "PATENTED" or patent number to enforce the patent protection.
 - 4) Failure to comply with stamping requirements will be cause for replacement of keys involved at no additional cost to Owner.
 - 5) Forward permanent cylinders/cores to Owner, separately from keys, by means as directed by Owner.
- e. Quantity: Furnish in the following quantities.
 - 1) Change (Day) Keys: 3 per cylinder/core.
 - 2) Permanent Control Keys: 3.
 - 3) Master Keys: 6.

2.09 DOOR CLOSERS

- A. Manufacturers and Products:
 1. Scheduled Manufacturer and Product:
 - a. Falcon SC80A series
 2. Acceptable Manufacturers and Products:
 - a. LCN 1450 series
 - b. Norton 8000 series
- B. Requirements:
 1. Provide door closers conforming to ANSI/BHMA A156.4 Grade 1 requirements by BHMA certified independent testing laboratory.
 2. Provide door closers with fully hydraulic, full rack and pinion action with aluminum cylinder.
 3. Closer Body: 1-1/4-inch (32 mm) diameter, with 5/8-inch (16 mm) diameter heat-treated pinion journal.
 4. Hydraulic Fluid: Fireproof, passing requirements of UL10C, and requiring no seasonal closer adjustment for temperatures ranging from 120 degrees F to -30 degrees F.
 5. Spring Power: Continuously adjustable over full range of closer sizes, and providing reduced opening force as required by accessibility codes and standards.
 6. Hydraulic Regulation: By tamper-proof, non-critical valves, with separate adjustment for latch speed, general speed, and backcheck.
 7. Pressure Relief Valve (PRV) Technology: Not permitted.
 8. Provide special templates, drop plates, mounting brackets, or adapters for arms as required for details, overhead stops, and other door hardware items interfering with closer mounting.

2.10 PROTECTION PLATES

- A. Manufacturers:
 1. Scheduled Manufacturer:
 - a. Ives
 2. Acceptable Manufacturers:
 - a. Burns
 - b. Trimco

- B. Requirements:
 - 1. Provide protection plates with a minimum of 0.050 inch (1 mm) thick, beveled four edges as scheduled. Furnish with sheet metal or wood screws, finished to match plates.
 - 2. Sizes plates 2 inches (51 mm) less width of door on single doors, pairs of doors with a mullion, and doors with edge guards. Size plates 1 inch (25 mm) less width of door on pairs without a mullion or edge guards.
 - 3. At fire rated doors, provide protection plates over 16 inches high with UL label.

2.11 OVERHEAD STOPS AND OVERHEAD STOP/HOLDERS

- A. Manufacturers:
 - 1. Scheduled Manufacturers:
 - a. Glynn-Johnson
 - 2. Acceptable Manufacturers:
 - a. Rixson
 - b. Sargent
 - c. ABH
- B. Requirements:
 - 1. Provide overhead stop at any door where conditions do not allow for a wall stop or floor stop presents tripping hazard.
 - 2. Provide friction type at doors without closer and positive type at doors with closer.

2.12 DOOR STOPS AND HOLDERS

- A. Manufacturers:
 - 1. Scheduled Manufacturer:
 - a. Ives
 - 2. Acceptable Manufacturers:
 - a. Trimco
 - b. Burns
 - c. Rockwood
- B. Provide door stops at each door leaf:
 - 1. Provide wall stops wherever possible. Provide concave type where lockset has a push button of thumbturn.
 - 2. Where a wall stop cannot be used, provide universal floor stops.
 - 3. Where wall or floor stop cannot be used, provide overhead stop.
 - 4. Provide roller bumper where doors open into each other and overhead stop cannot be used.

2.13 THRESHOLDS, SEALS, DOOR SWEEPS, AUTOMATIC DOOR BOTTOMS, AND GASKETING

- A. Manufacturers:
 - 1. Scheduled Manufacturer:
 - a. Zero International
 - 2. Acceptable Manufacturers:
 - a. National Guard
 - b. Reese
 - c. Legacy
 - d. Pemko
- B. Requirements:
 - 1. Provide thresholds, weather-stripping, and gasketing systems as specified and per architectural details. Match finish of other items.
 - 2. Smoke- and Draft-Control Door Assemblies: Where smoke- and draft-control door assemblies are required, provide door hardware that meets requirements of assemblies tested according to UL 1784 and installed in compliance with NFPA 105.
 - 3. Provide door sweeps, seals, astragals, and auto door bottoms only of type where resilient or flexible seal strip is easily replaceable and readily available.
 - 4. Size thresholds 1/2 inch (13 mm) high by 5 inches (127 mm) wide by door width unless otherwise specified in the hardware sets or detailed in the drawings.

2.14 SILENCERS

- A. Manufacturers:
 - 1. Scheduled Manufacturer:
 - a. Ives
 - 2. Acceptable Manufacturers:
 - a. Burns
 - b. Rockwood
 - c. Trimco
- B. Requirements:
 - 1. Provide "push-in" type silencers for hollow metal or wood frames.
 - 2. Provide one silencer per 30 inches (762 mm) of height on each single frame, and two for each pair frame.
 - 3. Omit where gasketing is specified.

2.15 FINISHES

- A. FINISH: BHMA 626/652 (US26D); EXCEPT:
 - 1. Hinges at Exterior Doors: BHMA 630 (US32D)
 - 2. Aluminum Geared Continuous Hinges: BHMA 628 (US28)
 - 3. Push Plates, Pulls, and Push Bars: BHMA 630 (US32D)
 - 4. Protection Plates: BHMA 630 (US32D)
 - 5. Overhead Stops and Holders: BHMA 630 (US32D)
 - 6. Door Closers: Powder Coat to Match
 - 7. Wall Stops: BHMA 630 (US32D)
 - 8. Latch Protectors: BHMA 630 (US32D)
 - 9. Weatherstripping: Clear Anodized Aluminum
 - 10. Thresholds: Mill Finish Aluminum

PART 3 - EXECUTION**3.01 EXAMINATION**

- A. Prior to installation of hardware, examine doors and frames, with Installer present, for compliance with requirements for installation tolerances, labeled fire-rated door assembly construction, wall and floor construction, and other conditions affecting performance. Verify doors, frames, and walls have been properly reinforced for hardware installation.
- B. Field verify existing doors and frames receiving new hardware and existing conditions receiving new openings. Verify that new hardware is compatible with existing door and frame preparation and existing conditions.
- C. Examine roughing-in for electrical power systems to verify actual locations of wiring connections before electrified door hardware installation.
- D. Submit a list of deficiencies in writing and proceed with installation only after unsatisfactory conditions have been corrected.

3.02 PREPARATION

- A. Where on-site modification of doors and frames is required:
 - 1. Carefully remove existing door hardware and components being reused. Clean, protect, tag, and store in accordance with storage and handling requirements specified herein.
 - 2. Field modify and prepare existing doors and frames for new hardware being installed.
 - 3. When modifications are exposed to view, use concealed fasteners, when possible.
 - 4. Prepare hardware locations and reinstall in accordance with installation requirements for new door hardware and with:
 - a. Steel Doors and Frames: For surface applied door hardware, drill and tap doors and frames according to ANSI/SDI A250.6.
 - b. Wood Doors: DHI WDHS.5 "Recommended Hardware Reinforcement Locations for Mineral Core Wood Flush Doors."
 - c. Doors in rated assemblies: NFPA 80 for restrictions on on-site door hardware preparation.

3.03 INSTALLATION

- A. Mount door hardware units at heights to comply with the following, unless otherwise indicated or required to comply with governing regulations.
 - 1. Standard Steel Doors and Frames: ANSI/SDI A250.8.
 - 2. Custom Steel Doors and Frames: HMMA 831.
 - 3. Interior Architectural Wood Flush Doors: ANSI/WDMA I.S. 1A
 - 4. Installation Guide for Doors and Hardware: DHI TDH-007-20
- B. Install door hardware in accordance with NFPA 80, NFPA 101 and provide post-install inspection, testing as specified in section 1.03.E unless otherwise required to comply with governing regulations.
- C. Install each hardware item in compliance with manufacturer's instructions and recommendations, using only fasteners provided by manufacturer.
- D. Do not install surface mounted items until finishes have been completed on substrate. Protect all installed hardware during painting.
- E. Set units level, plumb and true to line and location. Adjust and reinforce attachment substrate as necessary for proper installation and operation.
- F. Drill and countersink units that are not factory prepared for anchorage fasteners. Space fasteners and anchors according to industry standards.
- G. Install operating parts so they move freely and smoothly without binding, sticking, or excessive clearance.
- H. Hinges: Install types and in quantities indicated in door hardware schedule but not fewer than quantity recommended by manufacturer for application indicated.
- I. Lock Cylinders:
 - 1. Install construction cores to secure building and areas during construction period.
 - 2. Replace construction cores with permanent cores as indicated in keying section.
- J. Wiring: Coordinate with Division 26, ELECTRICAL and Division 28 ELECTRONIC SAFETY AND SECURITY sections for:
 - 1. Conduit, junction boxes and wire pulls.
 - 2. Connections to and from power supplies to electrified hardware.
 - 3. Connections to fire/smoke alarm system and smoke evacuation system.
 - 4. Connection of wire to door position switches and wire runs to central room or area, as directed by Architect.
 - 5. Connections to panel interface modules, controllers, and gateways.
 - 6. Testing and labeling wires with Architect's opening number.
- K. Key Control System: Tag keys and place them on markers and hooks in key control system cabinet, as determined by final keying schedule.
- L. Door Closers: Mount closers on room side of corridor doors, inside of exterior doors, and stair side of stairway doors from corridors. Mount closers so they are not visible in corridors, lobbies and other public spaces unless approved by Architect.
- M. Power Supplies: Locate power supplies as indicated or, if not indicated, above accessible ceilings or in equipment room, or alternate location as directed by Architect.
- N. Thresholds: Set thresholds in full bed of sealant complying with requirements specified in Division 07 Section "Joint Sealants."
- O. Stops: Provide floor stops for doors unless wall or other type stops are indicated in door hardware schedule. Do not mount floor stops where they may impede traffic or present tripping hazard.
- P. Perimeter Gasketing: Apply to head and jamb, forming seal between door and frame.
- Q. Meeting Stile Gasketing: Fasten to meeting stiles, forming seal when doors are closed.
- R. Door Bottoms and Sweeps: Apply to bottom of door, forming seal with threshold when door is closed.

3.04 ADJUSTING

- A. Initial Adjustment: Adjust and check each operating item of door hardware and each door to ensure proper operation or function of every unit. Replace units that cannot be adjusted to operate as intended. Adjust door control devices to compensate for final operation of heating and ventilating equipment and to comply with referenced accessibility requirements.

- 1. Door Closers: Adjust sweep period to comply with accessibility requirements and requirements of authorities having jurisdiction.
- B. Occupancy Adjustment: Approximately three to six months after date of Substantial Completion, examine and readjust each item of door hardware, including adjusting operating forces, as necessary to ensure function of doors and door hardware.

3.05 CLEANING AND PROTECTION

- A. Clean adjacent surfaces soiled by door hardware installation.
- B. Clean operating items per manufacturer's instructions to restore proper function and finish.
- C. Provide final protection and maintain conditions that ensure door hardware is without damage or deterioration at time of Substantial Completion.

3.06 DOOR HARDWARE SCHEDULE

- A. The intent of the hardware specification is to specify the hardware for interior and exterior doors, and to establish a type, continuity, and standard of quality. However, it is the door hardware supplier's responsibility to thoroughly review existing conditions, schedules, specifications, drawings, and other Contract Documents to verify the suitability of the hardware specified.
- B. Discrepancies, conflicting hardware, and missing items are to be brought to the attention of the architect with corrections made prior to the bidding process. Omitted items not included in a hardware set should be scheduled with the appropriate additional hardware required for proper application.
- C. Hardware items are referenced in the following hardware schedule. Refer to the above specifications for special features, options, cylinders/keying, and other requirements.
- D. Hardware Sets:

Hardware Group No. HW-01

For use on Door #(s):

109

Provide each door(s) with the following:

| QTY | | DESCRIPTION | CATALOG NUMBER | | FINISH | MFR |
|-----|----|-------------------|-------------------------------|--|--------|-----|
| 3 | EA | HINGE | 5BB1 4.5 X 4.5 | | 652 | IVE |
| 1 | EA | STOREROOM LOCK | MA581L DG | | 626 | FAL |
| 1 | EA | CYLINDER | AS REQUIRED TO MATCH EXISTING | | 626 | |
| 1 | EA | ELECTRIC STRIKE | PROVIDED BY SECURITY | | | |
| 1 | EA | SURFACE CLOSER | SC81A REG OR PA AS REQ | | 689 | FAL |
| 1 | EA | KICK PLATE | 8400 10" X 2" LDW B-CS | | 630 | IVE |
| 1 | EA | WALL STOP | WS406/407CCV | | 630 | IVE |
| 3 | EA | SILENCER | SR64/65 AS REQ | | GRY | IVE |
| | | | AT NON-RATED | | | |
| 1 | EA | CREDENTIAL READER | PROVIDED BY SECURITY | | | |
| 1 | EA | POWER SUPPLY | PROVIDED BY SECURITY | | | |

1. DOOR FUNCTION: DOOR NORMALLY CLOSED AND LOCKED. PRESENTING VALID CREDENTIAL AT READER WILL RELEASE ELECTRIC STRIKE AND ALLOW FOR ENTRY. DOOR ALWAYS AVAILABLE FOR FREE EGRESS.

2. ACCESS CONTROL PROVIDED BY SECURITY VENDOR.

Hardware Group No. HW-02

For use on Door #(s):

108

Provide each door(s) with the following:

| QTY | | DESCRIPTION | CATALOG NUMBER | | FINISH | MFR |
|-----|----|-------------------|-------------------------------|---|--------|-----|
| 3 | EA | HINGE | 5BB1 5 X 4.5 NRP | | 652 | IVE |
| 1 | EA | STOREROOM LOCK | MA581L DG | | 626 | FAL |
| 1 | EA | CYLINDER | AS REQUIRED TO MATCH EXISTING | | 626 | |
| 1 | EA | ELECTRIC STRIKE | PROVIDED BY SECURITY | ⚡ | | |
| 1 | EA | SURFACE CLOSER | SC81A REG OR PA AS REQ | | 689 | FAL |
| 1 | EA | WALL STOP | WS406/407CCV | | 630 | IVE |
| 3 | EA | SILENCER | SR64/65 AS REQ | | GRY | IVE |
| | | | AT NON-RATED | | | |
| 1 | EA | CREDENTIAL READER | PROVIDED BY SECURITY | ⚡ | | |
| 1 | EA | POWER SUPPLY | PROVIDED BY SECURITY | ⚡ | | |
| 1 | EA | WIRING DIAGRAM | AS REQUIRED | ⚡ | | DLR |

1. DOOR FUNCTION: DOOR NORMALLY CLOSED AND LOCKED. PRESENTING VALID CREDENTIAL AT READER WILL RELEASE ELECTRIC STRIKE AND ALLOW FOR ENTRY. DOOR ALWAYS AVAILABLE FOR FREE EGRESS.

2. ACCESS CONTROL PROVIDED BY SECURITY VENDOR.

Hardware Group No. HW-03

For use on Door #(s):

110

Provide each door(s) with the following:

| QTY | | DESCRIPTION | CATALOG NUMBER | | FINISH | MFR |
|-----|----|-------------------|-------------------------------|---|--------|-----|
| 3 | EA | HINGE | 5BB1 5 X 4.5 | | 652 | IVE |
| 1 | EA | STOREROOM LOCK | MA581L DG | | 626 | FAL |
| 1 | EA | CYLINDER | AS REQUIRED TO MATCH EXISTING | | 626 | |
| 1 | EA | ELECTRIC STRIKE | PROVIDED BY SECURITY | ⚡ | | |
| 1 | EA | SURFACE CLOSER | SC81A REG OR PA AS REQ | | 689 | FAL |
| 1 | EA | KICK PLATE | 8400 10" X 2" LDW B-CS | | 630 | IVE |
| 1 | EA | WALL STOP | WS406/407CCV | | 630 | IVE |
| 3 | EA | SILENCER | SR64/65 AS REQ | | GRY | IVE |
| | | | AT NON-RATED | | | |
| 1 | EA | CREDENTIAL READER | PROVIDED BY SECURITY | ⚡ | | |
| 1 | EA | POWER SUPPLY | PROVIDED BY SECURITY | ⚡ | | |
| 1 | EA | WIRING DIAGRAM | AS REQUIRED | ⚡ | | DLR |

1. DOOR FUNCTION: DOOR NORMALLY CLOSED AND LOCKED. PRESENTING VALID CREDENTIAL AT READER WILL RELEASE ELECTRIC STRIKE AND ALLOW FOR ENTRY. DOOR ALWAYS AVAILABLE FOR FREE EGRESS.







2. ACCESS CONTROL PROVIDED BY SECURITY VENDOR.

Hardware Group No. HW-04

For use on Door #(s):

112

Provide each door(s) with the following:

| QTY | | DESCRIPTION | CATALOG NUMBER | | FINISH | MFR |
|-----|----|----------------------------|------------------------------------|---|--------|-----|
| 3 | EA | HINGE | 5BB1 4.5 X 4.5 NRP |  | 652 | IVE |
| 1 | EA | DOOR CORD | PROVIDED BY SECURITY | | | |
| 1 | EA | ELEC FIRE EXIT HARDWARE | RX-FSA-F-25-R-L-DANE-CYL 24 VDC |  ⚡ | 622 | FAL |
| 1 | EA | CYLINDER | AS REQUIRED TO MATCH EXISTING | | 626 | |
| 1 | EA | ELECTRIC STRIKE | PROVIDED BY SECURITY | ⚡ | | |
| 1 | EA | SURFACE CLOSER | SC81A SS |  | 689 | FAL |
| 1 | EA | KICK PLATE | 8400 10" X 2" LDW B-CS |  | 630 | IVE |
| 1 | EA | WALL STOP | WS406/407CCV |  | 630 | IVE |
| 1 | EA | GASKETING | 488SBK PSA |  | BK | ZER |
| 1 | EA | CREDENTIAL READER | PROVIDED BY SECURITY | ⚡ | | |
| 1 | EA | POWER SUPPLY | PROVIDED BY SECURITY | ⚡ | | |

1. THE HARDWARE SUPPLIER SHALL COORDINATE THE ELECTRIFIED HARDWARE WITH ALL RELATED TRADES.

2. DOOR FUNCTION: DOOR NORMALLY CLOSED AND LOCKED. PRESENTING VALID CREDENTIAL AT READER WILL UNLOCK ELECTRIFIED LOCK TRIM AND ALLOW FOR ENTRY. DOOR ALWAYS AVAILABLE FOR FREE EGRESS. LOSS OF POWER, SIGNAL FROM FIRE ALARM SYSTEM WILL RELEASE LOCKING.

3. CREDENTIALS, READER, POWER SUPPLY AND CONNECTIONS TO THE OWNER'S NETWORK PROVIDED BY ACCESS CONTROL PROVIDER. ALL OTHER WORK PROVIDED BY ELECTRICAL CONTRACTOR.

Hardware Group No. HW-05

For use on Door #(s):

121

Provide each door(s) with the following:

| QTY | | DESCRIPTION | CATALOG NUMBER | | FINISH | MFR |
|-----|-----|---------------------|--------------------------------|--|--------|-----|
| 6 | EA | HINGE | 5BB1 4.5 X 4.5 NRP | | 652 | IVE |
| 1 | EA | DOOR CORD | PROVIDED BY SECURITY | | | |
| 1 | SET | CONST LATCHING BOLT | FB61P | | 630 | IVE |
| 1 | EA | DUST PROOF STRIKE | DP2 | | 626 | IVE |
| 1 | EA | STOREROOM LOCK | MA581L DG | | 626 | FAL |
| 1 | EA | CYLINDER | AS REQUIRED TO MATCH EXISTING | | 626 | |
| 1 | EA | ELECTRIC STRIKE | PROVIDED BY SECURITY | | | |
| 2 | EA | SURFACE CLOSER | SC81A SS | | 689 | FAL |
| 2 | EA | KICK PLATE | 8400 10" X 1" LDW B-CS | | 630 | IVE |
| 2 | EA | SILENCER | SR64/65 AS REQ AT NON-RATED | | GRY | IVE |
| 1 | EA | CREDENTIAL READER | PROVIDED BY SECURITY | | | |
| 1 | EA | POWER SUPPLY | PROVIDED BY SECURITY | | | |
| 1 | EA | WIRING DIAGRAM | AS REQUIRED | | | DLR |

1. DOOR FUNCTION: DOOR NORMALLY CLOSED AND LOCKED. PRESENTING VALID CREDENTIAL AT READER WILL RELEASE ELECTRIC STRIKE AND ALLOW FOR ENTRY. DOOR ALWAYS AVAILABLE FOR FREE EGRESS.

2. ACCESS CONTROL PROVIDED BY SECURITY VENDOR.

Hardware Group No. HW-06

For use on Door #(s):

120

122

123

Provide each door(s) with the following:

| QTY | | DESCRIPTION | CATALOG NUMBER | | FINISH | MFR |
|-----|----|-------------------|--------------------------------|--|--------|-----|
| 3 | EA | HINGE | 5BB1 4.5 X 4.5 | | 652 | IVE |
| 1 | EA | STOREROOM LOCK | MA581L DG | | 626 | FAL |
| 1 | EA | CYLINDER | AS REQUIRED TO MATCH EXISTING | | 626 | |
| 1 | EA | ELECTRIC STRIKE | PROVIDED BY SECURITY | | | |
| 1 | EA | OH STOP | 90S | | 689 | GLY |
| 1 | EA | SURFACE CLOSER | SC81A REG OR PA AS REQ | | 689 | FAL |
| 1 | EA | KICK PLATE | 8400 10" X 2" LDW B-CS | | 630 | IVE |
| 3 | EA | SILENCER | SR64/65 AS REQ AT NON-RATED | | GRY | IVE |
| 1 | EA | CREDENTIAL READER | PROVIDED BY SECURITY | | | |
| 1 | EA | POWER SUPPLY | PROVIDED BY SECURITY | | | |

1. DOOR FUNCTION: DOOR NORMALLY CLOSED AND LOCKED. PRESENTING VALID CREDENTIAL AT READER WILL RELEASE ELECTRIC STRIKE AND ALLOW FOR ENTRY. DOOR ALWAYS AVAILABLE FOR FREE EGRESS.

2. ACCESS CONTROL PROVIDED BY SECURITY VENDOR.

END OF SECTION

SECTION 08 80 00
GLAZING**PART 1 GENERAL****1.01 SECTION INCLUDES**

- A. Glass.

1.02 RELATED REQUIREMENTS

- A. Section 07 90 05 - Joint Sealers: Sealant and back-up material.
- B. Section 08 14 16 – Flush Wood Doors: Glazed lites in doors.
- C. Section 08 43013 – Aluminum-Framed Storefronts: Glazed lites in doors and frames.

1.03 REFERENCE STANDARDS

- A. 16 CFR 1201 - Safety Standard for Architectural Glazing Materials; current edition.
- B. ASTM C864 - Standard Specification for Dense Elastomeric Compression Seal Gaskets, Setting Blocks, and Spacers; 2005 (Reapproved 2011).
- C. ASTM C920 - Standard Specification for Elastomeric Joint Sealants; 2014.
- D. ASTM C1036 - Standard Specification for Flat Glass; 2011.
- E. ASTM C1048 - Standard Specification for Heat-Strengthened and Fully Tempered Flat Glass; 2012.
- F. ASTM C1172 - Standard Specification for Laminated Architectural Flat Glass; 2014.
- G. ASTM C1193 - Standard Guide for Use of Joint Sealants; 2013.
- H. ASTM E1300 - Standard Practice for Determining Load Resistance of Glass in Buildings; 2012a.
- I. ASTM E2190 - Standard Specification for Insulating Glass Unit Performance and Evaluation; 2010.
- J. GANA (GM) - GANA Glazing Manual; 2009.
- K. GANA (SM) - GANA Sealant Manual; 2008.

1.04 ADMINISTRATIVE REQUIREMENTS

- A. Preinstallation Meeting: Convene a preinstallation meeting one week before starting work of this section; require attendance by all affected installers.

1.05 SUBMITTALS

- A. Product Data on Glass Types: Provide structural, physical and environmental characteristics, size limitations, special handling or installation requirements.
- B. Product Data on Glazing Compounds: Provide chemical, functional, and environmental characteristics, limitations, special application requirements. Identify available colors.

1.06 QUALITY ASSURANCE

- A. Perform Work in accordance with GANA Glazing Manual and GANA Sealant Manual for glazing installation methods.
- B. Installer Qualifications: Company specializing in performing the work of this section with minimum three years documented experience.

1.07 FIELD CONDITIONS

- A. Do not install glazing when ambient temperature is less than 50 degrees F.
- B. Maintain minimum ambient temperature before, during and 24 hours after installation of glazing compounds.

1.08 WARRANTY

- A. See Section 01 78 00 - Closeout Submittals, for additional warranty requirements.
- B. Laminated Glass: Provide a five (5) year warranty to include coverage for delamination, including replacement of failed units.

PART 2 PRODUCTS**2.01 GLAZING UNITS**

- A. Type GL-1 - Single Vision Glazing:
 - 1. Type: Fully tempered 20-minute fire rated glass.
 - 2. Tint: Clear.
 - 3. Thickness: 1/4 inch.
 - 4. Glazing Method: Gasket glazing.
- B. Type GL-2 - Single Vision Glazing:
 - 1. Type: Fully tempered glass.
 - 2. Tint: Clear.
 - 3. Thickness: 1/4 inch.
 - 4. Glazing Method: Gasket glazing.

2.02 GLASS MATERIALS

- A. Float Glass: Provide float glass based glazing unless noted otherwise.
 - 1. Annealed Type: ASTM C1036, Type I - Transparent Flat, Class 1 - Clear, Quality-Q3.
 - 2. Heat-Strengthened and Fully Tempered Types: ASTM C1048, Kind HS and Kind FT.
 - 3. Tinted Types: ASTM C1036, Class 2 - Tinted, color and performance characteristics as indicated.
 - 4. Thicknesses: As indicated; for exterior glazing comply with requirements indicated for wind load design regardless of thickness indicated.

2.03 GLAZING COMPOUNDS

- A. Silicone Sealant: Single component; neutral curing; capable of water immersion without loss of properties; non-bleeding, non-staining; ASTM C920, Type S, Grade NS, Class 25, Uses M, A, and G; with cured Shore A hardness range of 15 to 25; color as selected.

2.07 GLAZING ACCESSORIES

- A. Glazing Gaskets: Resilient silicone extruded shape to suit glazing channel retaining slot; ASTM C864 Option II; Black color.
- B. Glazing Clips: Manufacturer's standard type.

PART 3 EXECUTION**3.01 EXAMINATION**

- A. Verify that openings for glazing are correctly sized and within tolerance.
- B. Verify that surfaces of glazing channels or recesses are clean, free of obstructions that may impede moisture movement, weeps are clear, and ready to receive glazing.

3.02 PREPARATION

- A. Clean contact surfaces with solvent and wipe dry.
- B. Seal porous glazing channels or recesses with substrate compatible primer or sealer.
- C. Prime surfaces scheduled to receive sealant.
- D. Install sealants in accordance with ASTM C1193 and GANA Sealant Manual.
- E. Install sealants in accordance with manufacturer's instructions.

3.03 INSTALLATION - INTERIOR DRY METHOD (TAPE AND TAPE)

- A. Cut glazing tape to length and set against permanent stops, projecting 1/16 inch above sight line.

- B. Place setting blocks at 1/4 points with edge block no more than 6 inch from corners.
- C. Rest glazing on setting blocks and push against tape for full contact at perimeter of pane or unit.
- D. Place glazing tape on free perimeter of glazing in same manner described above.
- E. Install removable stop without displacement of tape. Exert pressure on tape for full continuous contact.
- F. Knife trim protruding tape.

3.04 CLEANING

- A. Remove glazing materials from finish surfaces.
- B. Remove labels after Work is complete.
- C. Clean glass and adjacent surfaces.

END OF SECTION

SECTION 09 21 16
GYPSUM BOARD ASSEMBLIES**PART 1 GENERAL****101 SECTION INCLUDES**

- A. Gypsum wallboard.
- B. Joint treatment and accessories.

102 REFERENCE STANDARDS

- A. ASTM C1396/C1396M - Standard Specification for Gypsum Board; 2014.
- B. ASTM C475/C475M - Standard Specification for Joint Compound and Joint Tape for Finishing Gypsum Board; 2015.
- C. ASTM C840 - Standard Specification for Application and Finishing of Gypsum Board; 2013.
- D. ASTM C1002 - Standard Specification for Steel Self-Piercing Tapping Screws for Application of Gypsum Panel Products or Metal Plaster Bases to Wood Studs or Steel Studs; 2014.
- E. ASTM C1047 - Standard Specification for Accessories For Gypsum Wallboard and Gypsum Veneer Base; 2014a.
- F. ASTM C1396/C1396M - Standard Specification for Gypsum Board; 2014.
- G. GA-216 - Application and Finishing of Gypsum Board; 2013.

103 SUBMITTALS

- A. Product Data: Provide data on gypsum board, accessories, and joint finishing system.

104 QUALITY ASSURANCE

- A. Installer Qualifications: Company specializing in performing gypsum board installation and finishing, with minimum years of experience, with minimum 3 years of documented experience.

PART 2 PRODUCTS**201 BOARD MATERIALS**

- A. Gypsum Wallboard: Paper-faced gypsum panels as defined in ASTM C1396/C1396M; sizes to minimize joints in place; ends square cut.
 - 1. Application: Use for vertical surfaces and ceilings, unless otherwise indicated.
 - 2. At Assemblies with Fire-Rating: Use type required by indicated tested assembly; if no tested assembly is indicated, use Type X board, UL listed.
 - 3. Thickness:
 - a. Vertical Surfaces: 5/8 inch.
 - b. Ceilings: 5/8 inch.

202 ACCESSORIES

- A. Beads, Joint Accessories, and Other Trim: ASTM C1047, galvanized steel or rolled zinc, unless noted otherwise.
- B. Joint Materials: ASTM C475/C475M and as recommended by gypsum board manufacturer for project conditions.
 - 1. Tape: 2 inch wide, coated glass fiber tape for joints and corners.
 - 2. Tape: 2 inch wide, creased paper tape for joints and corners, except as otherwise indicated.
 - 3. Ready-mixed vinyl-based joint compound.
- C. Screws for Fastening of Gypsum Panel Products to Cold-Formed Steel Studs Less than 0.033 inch in Thickness and Wood Members: ASTM C1002; self-piercing tapping screws, corrosion resistant.

PART 3 EXECUTION**301 EXAMINATION**

- A. Verify that project conditions are appropriate for work of this section to commence.

302 INSTALLATION OF TRIM AND ACCESSORIES

- A. Control Joints: Place control joints consistent with lines of building spaces and as indicated.
 - 1. Not more than 30 feet apart on walls and ceilings over 50 feet long.
- B. Corner Beads: Install at external corners, using longest practical lengths.
- C. Edge Trim: Install at locations where gypsum board abuts dissimilar materials.

303 JOINT TREATMENT

- A. Paper Faced Gypsum Board: Use paper joint tape, bedded with ready-mixed vinyl-based joint compound and finished with ready-mixed vinyl-based joint compound.
- B. Finish gypsum board in accordance with levels defined in ASTM C840, as follows:
 - 1. Level 4: Walls and ceilings to receive paint finish or wall coverings, unless otherwise indicated.
- C. Tape, fill, and sand exposed joints, edges, and corners to produce smooth surface ready to receive finishes.
 - 1. Feather coats of joint compound so that camber is maximum 1/32 inch.

304 TOLERANCES

- A. Maximum Variation of Finished Gypsum Board Surface from True Flatness: 1/8 inch in 10 feet in any direction.

END OF SECTION

SECTION 09 51 00
ACOUSTICAL CEILINGS**PART 1 GENERAL****1.01 SECTION INCLUDES**

- A. Suspended metal grid ceiling system.
- B. Acoustical units.

1.02 REFERENCE STANDARDS

- A. ASTM C635/C635M - Standard Specification for the Manufacture, Performance, and Testing of Metal Suspension Systems for Acoustical Tile and Lay-in Panel Ceilings; 2013a.
- B. ASTM C636/C636M - Standard Practice for Installation of Metal Ceiling Suspension Systems for Acoustical Tile and Lay-In Panels; 2013.
- C. ASTM E580/E580M - Standard Practice for Installation of Ceiling Suspension Systems for Acoustical Tile and Lay-in Panels in Areas Subject to Earthquake Ground Motions; 2014.

1.03 SUBMITTALS

- A. Product Data: Provide data on suspension system components.
- B. Samples: Submit two samples 6" by 6" inch in size illustrating material and finish of acoustical units.
- C. Samples: Submit two samples each, 6" inches long, of suspension system main runner.
- D. Manufacturer's Installation Instructions: Indicate special procedures.

1.04 QUALITY ASSURANCE

- A. Suspension System Manufacturer Qualifications: Company specializing in manufacturing the products specified in this section with minimum three years documented experience.

PART 2 PRODUCTS**2.01 ACOUSTICAL UNITS**

- A. Manufacturers:
 - 1. USG: www.usg.com.
 - 2. Armstrong: www.armstrongceilings.com
 - 3. Substitutions: Permitted if products meet the requirements of this specification.
- B. ACT-1 Acoustical Units – Mars High-NRC SLT 87200 by USG.
 - 1. Size: 24 by 48 inches.
 - 2. Thickness: 1 inch.
 - 3. Edge: Square Edge.
 - 4. Surface Color: White.

2.02 SUSPENSION SYSTEM(S)

- A. Suspension Systems - General: Complying with ASTM C635/C635M; die cut and interlocking components, with clips, splices, and perimeter moldings as required.
- B. Exposed Steel Suspension System: Formed steel, commercial quality cold rolled; heavy-duty.
 - 1. Profile: Tee; 15/16 inch wide face.
 - 2. Construction: Double web.
 - 3. Finish: White painted.

2.03 ACCESSORIES

- A. Support Channels and Hangers: Galvanized steel; size and type to suit application, seismic requirements, and ceiling system flatness requirement specified.
- B. Perimeter Moldings: Same material and finish as grid.
 - 1. At Exposed Grid: Provide L-shaped molding for mounting at same elevation as face of grid.
- C. Touch-up Paint: Type and color to match acoustical and grid units.

PART 3 EXECUTION**3.01 EXAMINATION**

- A. Verify existing conditions before starting work.
- B. Verify that layout of hangers will not interfere with other work.

3.02 INSTALLATION - SUSPENSION SYSTEM

- A. Install suspension system in accordance with ASTM C636/C636M, ASTM E580/E580M, and manufacturer's instructions and as supplemented in this section.
- B. Install suspension system in accordance with ASTM E 580 for Areas Subject to Severe Severe Seismic Disturbance.
- C. Rigidly secure system, including integral mechanical and electrical components, for maximum deflection of 1:360.
- D. Lay out system to a balanced grid design with edge units no less than 50 percent of acoustical unit size.
- E. Install after major above-ceiling work is complete. Coordinate the location of hangers with other work.
- F. Hang suspension system independent of walls, columns, ducts, pipes and conduit. Where carrying members are spliced, avoid visible displacement of face plane of adjacent members.
- G. Where ducts or other equipment prevent the regular spacing of hangers, reinforce the nearest affected hangers and related carrying channels to span the extra distance.
- H. Do not support components on main runners or cross runners if weight causes total dead load to exceed deflection capability.
- I. Support fixture loads using supplementary hangers located within 6 inches of each corner, or support components independently.
- J. Do not eccentrically load system or induce rotation of runners.
- K. Perimeter Molding: Install at intersection of ceiling and vertical surfaces and at junctions with other interruptions.
 - 1. Use longest practical lengths.
 - 2. Overlap and rivet corners.

3.03 INSTALLATION - ACOUSTICAL UNITS

- A. Install acoustical units in accordance with manufacturer's instructions.
- B. Fit acoustical units in place, free from damaged edges or other defects detrimental to appearance and function.
- C. Fit border trim neatly against abutting surfaces.
- D. Install units after above-ceiling work is complete.
- E. Install acoustical units level, in uniform plane, and free from twist, warp, and dents.
- F. Cutting Acoustical Units:
 - 1. Make field cut edges of same profile as factory edges.
 - 2. Double cut and field paint exposed reveal edges.

3.04 TOLERANCES

- A. Maximum Variation from Flat and Level Surface: 1/8 inch in 10 feet.
- B. Maximum Variation from Plumb of Grid Members Caused by Eccentric Loads: 2 degrees.

END OF SECTION

**SECTION 09 65 00
RESILIENT FLOORING****PART 1 GENERAL****1.01 SECTION INCLUDES**

- A. Resilient tile flooring.
- B. Installation accessories.

1.02 REFERENCE STANDARDS

- A. ASTM F710 - Standard Practice for Preparing Concrete Floors to Receive Resilient Flooring; 2011.
- B. ASTM F1700 - Standard Specification for Solid Vinyl Tile; 2013a.

1.03 SUBMITTALS

- A. See Section 01 30 00 - Administrative Requirements, for submittal procedures.
- B. Product Data: Provide data on specified products, describing physical and performance characteristics; including sizes, patterns and colors available; and installation instructions.
- C. Verification Samples: Submit two samples, 12 by 12 inch in size illustrating color and pattern for each resilient flooring product specified.
- D. Concrete Testing Standard: Submit a copy of ASTM F710.
- E. Maintenance Data: Include maintenance procedures, recommended maintenance materials, and suggested schedule for cleaning, stripping, and re-waxing.

1.04 DELIVERY, STORAGE, AND HANDLING

- A. Upon receipt, immediately remove any shrink-wrap and check materials for damage and the correct style, color, quantity and run numbers.
- B. Store all materials off of the floor in an acclimatized, weather-tight space.
- C. Maintain temperature in storage area between 55 degrees F and 90 degrees F.

PART 2 PRODUCTS**2.01 TILE FLOORING**

- A. High Performance Luxury Vinyl Tile.
 - 1. Manufacturer: Mohawk Group
 - a. Hot & Heavy Collection.
 - b. See drawings for color selections
 - 2. Minimum Requirements: Comply with ASTM F1700, of Class corresponding to type specified.
 - 3. Plank Size: 9 inches x 59 inches
 - 4. Wear Layer Thickness: 20 mil
 - 5. Total Thickness: 5mm

2.02 RESILIENT BASE

- A. Resilient Base: ASTM F1861, Type TS rubber, vulcanized thermoset; top set Style B, Cove, and as follows:
 - 1. Height: 4 inch.
 - 2. Thickness: 0.125 inch thick.
 - 3. Finish: Satin.
 - 4. Color: Color as selected from manufacturer's standards.

2.03 ACCESSORIES

- A. Subfloor Filler: White premix latex; type recommended by adhesive material manufacturer.
- B. Adhesives: Type recommended by flooring manufacturer.

PART 3 EXECUTION**3.01 EXAMINATION**

- A. Verify that surfaces are flat to tolerances acceptable to flooring manufacturer, free of cracks that might telegraph through flooring, clean, dry, and free of curing compounds, surface hardeners, and other chemicals that might interfere with bonding of flooring to substrate.
- B. Verify that wall surfaces are smooth and flat within the tolerances specified for that type of work, are dust-free, and are ready to receive resilient base.
- C. Cementitious Sub-floor Surfaces: Verify that substrates are dry enough and ready for resilient flooring installation by testing for moisture and pH.
 - 1. Test in accordance with ASTM F710.
 - 2. Obtain instructions if test results are not within limits recommended by resilient flooring manufacturer and adhesive materials manufacturer.
- D. Verify that required floor-mounted utilities are in correct location.

3.02 PREPARATION

- A. Prepare floor substrates as recommended by flooring and adhesive manufacturers.
- B. Clean substrate.

3.03 INSTALLATION - GENERAL

- A. Starting installation constitutes acceptance of sub-floor conditions.
- B. Install in accordance with manufacturer's written instructions.
- C. Luxury vinyl flooring shall be installed with adhesive. Spread only enough adhesive to permit installation of materials before initial set.
- D. Fit joints and butt seams tightly.
- E. Set flooring in place, press with heavy roller to attain full adhesion.
- F. Where type of floor finish, pattern, or color are different on opposite sides of door, terminate flooring under centerline of door.
- G. Install edge strips at unprotected or exposed edges, where flooring terminates, and where indicated.
 - 1. Metal Strips: Attach to substrate before installation of flooring using stainless steel screws.
- H. Scribe flooring to walls, columns, cabinets, floor outlets, and other appurtenances to produce tight joints.

3.04 INSTALLATION - TILE FLOORING

- A. Mix tile from container to ensure shade variations are consistent when tile is placed, unless otherwise indicated in manufacturer's installation instructions.

3.05 CLEANING

- A. Remove excess adhesive from floor, base, and wall surfaces without damage.
- B. Clean in accordance with manufacturer's written instructions.

3.06 PROTECTION

- A. Prohibit traffic on resilient flooring for 48 hours after installation.

END OF SECTION

SECTION 09 68 00
CARPETING**PART 1 GENERAL****1.01 SECTION INCLUDES**

- A. Carpet, direct-glued.

1.02 REFERENCE STANDARDS

- A. ASTM F710 - Standard Practice for Preparing Concrete Floors to Receive Resilient Flooring; 2011.
- B. CRI 104 - Standard for Installation of Commercial Carpet; 2015.
- C. CRI (GL) - Green Label Testing Program - Certified Products; Carpet and Rug Institute; Current Edition.

1.03 SUBMITTALS

- A. Product Data: Provide data on specified products, describing physical and performance characteristics; sizes, patterns, colors available, and method of installation.
- B. Manufacturer's Installation Instructions: Indicate special procedures.

1.04 QUALITY ASSURANCE

- A. Manufacturer Qualifications: Company specializing in manufacturing specified carpet with minimum three years documented experience.
- B. Installer Qualifications: Company specializing in installing carpet with minimum three years experience.

PART 2 PRODUCTS**2.01 CARPET**

- A. Carpet: As noted on the drawings.

2.02 ACCESSORIES

- A. Concrete Filler: Type recommended by carpet manufacturer.
- B. Adhesives:
 - 1. Compatible with materials being adhered; maximum VOC content of 50 g/L; CRI (GL) certified.
- C. Seam Adhesive: Recommended by carpet manufacturer.
- D. Carpet Adhesive: Recommended by carpet manufacturer.

PART 3 EXECUTION**3.01 EXAMINATION**

- A. Verify that sub-floor surfaces are smooth and flat within the tolerances specified for that type of work and are ready to receive carpet.
- B. Verify that sub-floor surfaces are dust-free and free of substances that could impair bonding of adhesives to sub floor surfaces.
- C. Cementitious Sub-floor Surfaces: Verify that substrates are dry enough and ready for flooring installation by testing for moisture and alkalinity (pH).
 - 1. Test in accordance with ASTM F710.
 - 2. Obtain instructions if test results are not within limits recommended by flooring material manufacturer and adhesive materials manufacturer.

302 PREPARATION

- A. Prepare floor substrates as recommended by flooring and adhesive manufacturers.
- B. Remove sub-floor ridges and bumps. Fill minor or local low spots, cracks, joints, holes, and other defects with sub-floor filler.

303 INSTALLATION - GENERAL

- A. Starting installation constitutes acceptance of sub-floor conditions.
- B. Install carpet in accordance with manufacturer's instructions and CRI 104 (Commercial).
- C. Verify carpet match before cutting to ensure minimal variation between dye lots.
- D. Lay out carpet.
 - 1. Locate seams in area of least traffic, out of areas of pivoting traffic, and parallel to main traffic.
 - 2. Do not locate seams perpendicular through door openings.
 - 3. Align run of pile in same direction as anticipated traffic and in same direction on adjacent pieces.
 - 4. Locate change of color or pattern between rooms under door centerline.
 - 5. Provide monolithic color, pattern, and texture match within any one area.
- E. Install carpet tight and flat on subfloor, well fastened at edges, with a uniform appearance.

304 DIRECT-GLUED CARPET

- A. Double cut carpet seams, with accurate pattern match. Make cuts straight, true, and unfrayed. Apply seam adhesive to cut edges of woven carpet immediately.
- B. Apply contact adhesive to floor uniformly at rate recommended by manufacturer. After sufficient open time, press carpet into adhesive.
- C. Apply seam adhesive to the base of the edge glued down. Lay adjoining piece with seam straight, not overlapped or peaked, and free of gaps.
- D. Roll with appropriate roller for complete contact of adhesive to carpet backing.
- E. Trim carpet neatly at walls and around interruptions.

305 CLEANING

- A. Remove excess adhesive from floor and wall surfaces without damage.
- B. Clean and vacuum carpet surfaces.

END OF SECTION

SECTION 09 90 00
PAINTING AND COATING**PART 1 GENERAL****1.01 SECTION INCLUDES**

- A. Surface preparation.
- B. Field application of paints.
- C. Scope: Finish all exterior and interior surfaces exposed to view, unless fully factory-finished and unless otherwise indicated.
- D. Do Not Paint or Finish the Following Items:
 - 1. Items fully factory-finished unless specifically so indicated; materials and products having factory-applied primers are not considered factory finished.
 - 2. Items indicated to receive other finishes.
 - 3. Items indicated to remain unfinished.
 - 4. Fire rating labels, equipment serial number and capacity labels, and operating parts of equipment.
 - 5. Glass.
 - 6. Concealed pipes, ducts, and conduits.

1.02 REFERENCE STANDARDS

- A. 40 CFR 59, Subpart D - National Volatile Organic Compound Emission Standards for Architectural Coatings; U.S. Environmental Protection Agency; current edition.
- B. ASTM D4442 - Standard Test Methods for Direct Moisture Content Measurement of Wood and Wood-Base Materials; 2007.

1.03 SUBMITTALS

- A. Product Data: Provide complete list of all products to be used, with the following information for each:
 - 1. Manufacturer's name, product name and/or catalog number, and general product category (e.g. "alkyd enamel").
 - 2. MPI product number (e.g. MPI #47).
 - 3. Cross-reference to specified paint system(s) product is to be used in; include description of each system.
- B. Samples: Submit three paper "draw down" samples, 8-1/2 by 11 inches in size, illustrating range of colors available for each finishing product specified.
 - 1. Where sheen is specified, submit samples in only that sheen.

1.05 QUALITY ASSURANCE

- A. Manufacturer Qualifications: Company specializing in manufacturing the products specified, with minimum five years documented experience.

1.06 DELIVERY, STORAGE, AND HANDLING

- A. Deliver products to site in sealed and labeled containers; inspect to verify acceptability.
- B. Container Label: Include manufacturer's name, type of paint, brand name, lot number, brand code, coverage, surface preparation, drying time, cleanup requirements, color designation, and instructions for mixing and reducing.
- C. Paint Materials: Store at minimum ambient temperature of 45 degrees F and a maximum of 90 degrees F, in ventilated area, and as required by manufacturer's instructions.

1.07 FIELD CONDITIONS

- A. Do not apply materials when surface and ambient temperatures are outside the temperature ranges required by the paint product manufacturer.
- B. Follow manufacturer's recommended procedures for producing best results, including testing of substrates, moisture in substrates, and humidity and temperature limitations.
- C. Do not apply exterior coatings during rain or snow, or when relative humidity is outside the humidity ranges required by the paint product manufacturer.
- D. Provide lighting level of 80 ft candles measured mid-height at substrate surface.

PART 2 PRODUCTS**2.01 MANUFACTURERS**

- A. Provide all paint and coating products used in any individual system from the same manufacturer; no exceptions.
- B. Provide all paint and coating products from the same manufacturer to the greatest extent possible.

2.02 PAINTS AND COATINGS - GENERAL

- A. Paints and Coatings: Ready mixed, unless intended to be a field-catalyzed coating.
 - 1. Provide paints and coatings of a soft paste consistency, capable of being readily and uniformly dispersed to a homogeneous coating, with good flow and brushing properties, and capable of drying or curing free of streaks or sags.
 - 2. Supply each coating material in quantity required to complete entire project's work from a single production run.
 - 3. Do not reduce, thin, or dilute coatings or add materials to coatings unless such procedure is specifically described in manufacturer's product instructions.
- B. Volatile Organic Compound (VOC) Content:
 - 1. Provide coatings that comply with the most stringent requirements specified in the following:
 - a. 40 CFR 59, Subpart D--National Volatile Organic Compound Emission Standards for Architectural Coatings.
 - 2. Determination of VOC Content: Testing and calculation in accordance with 40 CFR 59, Subpart D (EPA Method 24), exclusive of colorants added to a tint base and water added at project site; or other method acceptable to authorities having jurisdiction.
- C. Colors: To be selected from manufacturer's full range of available colors.
 - 1. Selection to be made by Architect after award of contract.

2.03 PAINT SYSTEMS - INTERIOR

- A. Paint WI-OP-3L - Wood, Opaque, Latex, 3 Coat:
 - 1. One coat of latex primer sealer.
 - 2. Semi-gloss: Two coats of latex enamel.
- B. Paint CI-OP-3L - Concrete/Masonry, Opaque, Latex, 3 Coat:
 - 1. One coat of block filler.
 - 2. Semi-gloss: Two coats of latex enamel.
- C. Paint MI-OP-3L - Ferrous Metals, Unprimed, Latex, 3 Coat:
 - 1. One coat of latex primer.
 - 2. Semi-gloss: Two coats of latex enamel.
- D. Paint MI-OP-2L - Ferrous Metals, Primed, Latex, 2 Coat:
 - 1. Touch-up with latex primer.
 - 2. Semi-gloss: Two coats of latex enamel.
- E. Paint GI-OP-3L - Gypsum Board/Plaster, Latex, 3 Coat:
 - 1. One coat of alkyd primer sealer.
 - 2. Satin: Two coats of latex enamel; Walls.
 - 3. Flat: Two coats of latex enamel; Ceilings.

2.05 ACCESSORY MATERIALS

- A. Accessory Materials: Provide all primers, sealers, cleaning agents, cleaning cloths, sanding materials, and clean-up materials required to achieve the finishes specified whether specifically indicated or not; commercial quality.
- B. Patching Material: Latex filler.
- C. Fastener Head Cover Material: Latex filler.

PART 3 EXECUTION**3.01 EXAMINATION**

- A. Do not begin application of coatings until substrates have been properly prepared.
- B. Verify that surfaces are ready to receive work as instructed by the product manufacturer.
- C. Examine surfaces scheduled to be finished prior to commencement of work. Report any condition that may potentially affect proper application.
- D. Test shop-applied primer for compatibility with subsequent cover materials.
- E. Measure moisture content of surfaces using an electronic moisture meter. Do not apply finishes unless moisture content of surfaces are below the following maximums:
 - 1. Gypsum Wallboard: 12 percent.
 - 2. Interior Wood: 15 percent, measured in accordance with ASTM D4442.
 - 3. Exterior Wood: 15 percent, measured in accordance with ASTM D4442.

3.02 PREPARATION

- A. Clean surfaces thoroughly and correct defects prior to coating application.
- B. Prepare surfaces using the methods recommended by the manufacturer for achieving the best result for the substrate under the project conditions.
- C. Remove or mask surface appurtenances, including electrical plates, hardware, light fixture trim, escutcheons, and fittings, prior to preparing surfaces or finishing.
- D. Seal surfaces that might cause bleed through or staining of topcoat.
- E. Remove mildew from impervious surfaces by scrubbing with solution of tetra-sodium phosphate and bleach. Rinse with clean water and allow surface to dry.
- F. Gypsum Board Surfaces to be Painted: Fill minor defects with filler compound. Spot prime defects after repair.
- G. Shop-Primed Steel Surfaces to be Finish Painted: Sand and scrape to remove loose primer and rust. Feather edges to make touch-up patches inconspicuous. Clean surfaces with solvent. Prime bare steel surfaces.
- H. Interior Wood Surfaces to Receive Opaque Finish: Wipe off dust and grit prior to priming. Seal knots, pitch streaks, and sappy sections with sealer. Fill nail holes and cracks after primer has dried; sand between coats. Back prime concealed surfaces before installation.
- I. Interior Wood Surfaces to Receive Transparent Finish: Wipe off dust and grit prior to sealing, seal knots, pitch streaks, and sappy sections with sealer. Fill nail holes and cracks after sealer has dried; sand lightly between coats. Prime concealed surfaces with gloss varnish reduced 25 percent with thinner
- J. Exterior Wood/Fiber Cement Surfaces to Receive Opaque Finish: Remove dust, grit, and foreign matter. Seal knots, pitch streaks, and sappy sections. Fill nail holes with tinted exterior calking compound after prime coat has been applied. Back prime concealed surfaces before installation.

3.03 APPLICATION

- A. Apply products in accordance with manufacturer's instructions.
- B. Where adjacent sealant is to be painted, do not apply finish coats until sealant is applied.
- C. Do not apply finishes to surfaces that are not dry. Allow applied coats to dry before next coat is applied.
- D. Apply each coat to uniform appearance.

- E. Sand wood and metal surfaces lightly between coats to achieve required finish.
- F. Vacuum clean surfaces of loose particles. Use tack cloth to remove dust and particles just prior to applying next coat.
- G. Reinstall electrical cover plates, hardware, light fixture trim, escutcheons, and fittings removed prior to finishing.

3.04 CLEANING

- A. Collect waste material that could constitute a fire hazard, place in closed metal containers, and remove daily from site.

3.05 PROTECTION

- A. Protect finished coatings until completion of project.
- B. Touch-up damaged coatings after Substantial Completion.

END OF SECTION

SECTION 23 00 00
BASIC MECHANICAL MATERIALS AND METHODS**PART 1 GENERAL****1.01 IMPOSED REGULATIONS**

- A. Applicable provisions of the State and Local Codes and of the following codes and standards in addition to those listed elsewhere in the specifications are hereby imposed on a general basis for mechanical work: codes and standards listed on the mechanical drawings.

1.02 SCOPE OF WORK

- A. Provide all labor, materials, equipment and supervision to construct complete and operable mechanical systems as indicated on the drawings and specified herein. All materials and equipment used shall be new, undamaged and free from any defects.

1.03 RELATED DOCUMENTS AND OTHER INFORMATION

- A. The general provisions of the Contract, including General and Supplementary Conditions and General Requirements, apply to the portions of work specified in each and every Section of this Division, individually and collectively.
- B. It is recognized that separate sub-contracts may be instituted by THIS CONTRACT'S GENERAL CONTRACTOR with others. It is the responsibility of THIS CONTRACT'S GENERAL CONTRACTOR to completely inform, coordinate and advise those sub-contractors as to all of the requirements, conditions and information associated with providing and installing their portion of the total job.

1.04 EXISTING SERVICES AND FACILITIES

- A. Damage to Existing Services: Existing services and facilities damaged by the Contractor through negligence or through use of faulty materials or workmanship shall be promptly repaired, replaced, or otherwise restored to previous conditions by the Contractor without additional cost to the Owner.
- B. Interruption of Services: Interruptions of services necessary for connection to or modification of existing systems or facilities shall occur only at prearranged times approved by the Owner. Interruptions shall only occur after the provision of all temporary work and the availability of adequate labor and materials will assure that the duration of the interruption will not exceed the time agreed upon.
- C. Removed Materials: Existing materials made unnecessary by the new installation shall be stored on site. They shall remain the property of the Owner and shall be stored at a location and in a manner as directed by the Owner. If classified by the Owner's authorized representative as unsuitable for further use, the material shall become the property of the Contractor and shall be removed from the site at no additional cost to the owner.

1.05 PRODUCT WARRANTIES

- A. Provide manufacturer's standard printed commitment in reference to a specific product and normal application, stating that certain acts of restitution will be performed for the Purchaser or Owner by the manufacturer, when and if the product fails within certain operational conditions and time limits. Where the warranty requirements of a specific specification section exceeds the manufacturer's standard warranty, the more stringent

requirements will apply and modified manufacturer's warranty shall be provided. In no case shall the manufacturer's warranty be less than one (1) year.

1.06 PRODUCT SUBSTITUTIONS

- A. General: Materials specified by manufacturer's name shall be used unless prior approval of an alternate is given by addenda. Requests for substitutions must be received in the office of the Architect at least 10 days prior to opening of bids. Refer to the general conditions for the substitution request form and required documentation.

PART 2 PRODUCTS

2.01 GENERAL MECHANICAL PRODUCT REQUIREMENTS

- A. Standard Products: Provide not less (quality) than manufacturer's standard products, as specified by their published product data. In addition to the indication that a particular product/model number is acceptable, comply with the specified requirements. Do not assume that the available off-the-shelf condition of a product complies with the requirements; as an example, a specific finish or color may be required.
- B. Uniformity: Where multiple units of a general product are required for the mechanical work, provide identical products by the same manufacturer, without variations except for sizes and similar variations as indicated.
- C. Product Compatibility, Options: Where more than one product selection is specified, either generically or proprietarily, selection is Purchaser's or Installer's option. Provide mechanical adaptations as needed for interfacing of selected products in the work.
- D. Equipment Nameplates: Provide a permanent operational data nameplate on each item of power operated mechanical equipment, indicating the manufacturer, product name, model number, serial number, speed, capacity, power characteristics, labels of tested compliance, and similar essential operating data.
- E. Locate nameplates in easy-to-read locations. When product is visually exposed in an occupied area of the building, locate nameplate in a concealed position (where possible) which is accessible for reading by service personnel.

PART 3 EXECUTION

3.01 PRODUCT INSTALLATION, GENERAL

- A. Except where more stringent requirements are indicated, comply with the product manufacturer's installation instructions and recommendations, including handling, anchorage, assembly, connections, cleaning and testing, charging, lubrication, startup, test operation and shut-down of operating equipment. Consult with manufacturer's technical experts, for specific instructions on unique product conditions and unforeseen problems.
- B. Protection and Identification: Deliver products to project properly identified with names, models numbers, types, grades, compliance labels and similar information needed for distinct identifications; adequately packaged or protected to prevent deterioration during shipment, storage and handling. Store in a dry, well ventilated, indoor space, except where prepared and protected by the manufacturer specifically for exterior storage.
- C. Permits and Tests: Provide labor, material and equipment to perform all tests required by the governing agencies and submit a record of all tests to the Owner or his representative. Notify the Architect five days in advance of any testing.

- D. Where components such as duct, pipe, conduit, etc. pass through non-fire-rated, interior partitions, fill void between component and opening in wall with fiberglass insulation and sealant for acoustical separation.

END OF SECTION

SECTION 23 05 10
MECHANICAL COORDINATION**PART 1 GENERAL****1.01 QUALITY ASSURANCE**

- A. Mechanical Coordination Drawings: Prepare a set of coordination drawings showing the coordination of the major elements, components and systems of the mechanical work, and showing the coordination of mechanical work with other work. Prepare drawings at accurate scale and sufficiently large to show locations of every item, including clearances for installing, maintaining, insulating, breaking down equipment, replacing motors and similar requirements. Drawings shall indicate coordination with all other trades including, but not limited to, lighting, structural, plumbing and architectural items. Where applicable, existing conditions shall be accounted for. Prepare drawings to include plans, elevations, sections and details as needed to conclusively show successful coordination and integration of the work. Submit drawings for review by the Architect/Engineer.

PART 2 PRODUCTS**2.01 MECHANICAL PRODUCT COORDINATION**

- A. Power Characteristics: Refer to the electrical sections of the specifications and the electrical drawings for the power characteristics available for the operation of each power driven item of mechanical equipment. The electrical design was based on the power requirements of the mechanical equipment manufacturer scheduled or specified as "basis of design." Any modifications to the electrical system that are required due to the use of an approved equivalent manufacturer shall be made at no additional cost to the owner. All changes must be clearly documented and submitted for review by the Architect/Engineer prior to purchasing equipment. Coordinate purchases to ensure uniform interface with electrical work. Refer to specification Div. 26 for additional coordination requirements.
- B. Coordination of Options and Substitutions: When the contract documents permit the selection from several product options and it becomes necessary to authorize a substitution, do not proceed with purchase until coordination of interface to equipment has been checked and satisfactorily established.

PART 3 EXECUTION**3.01 INSPECTION AND PREPARATION**

- A. Substrate Examination: The Installer of each element of the mechanical work must examine the condition of the substrate to receive the work, the conditions under which the work will be performed, and must notify the Contractor in writing of conditions detrimental to the proper completion of the work. Do not proceed with the work until unsatisfactory conditions have been corrected in a manner acceptable to the Installer.
- B. Do not proceed with the installation of sleeves, anchors, hangers, roof penetrations and similar work until mechanical coordination drawings have been processed and released for construction. Where work must be installed prior to that time in order to avoid a project delay, review proposed installation in a project coordination meeting including all parties involved with the interfacing of the work.

3.02 CUTTING AND PATCHING

- A. Structural Limitations: Do not cut structural framing, walls, floors, decks and other members intended to withstand stress, except with the Architect's or Engineer's written authorization. Authorization will be granted only where there is not other reasonable method for completing the mechanical work, and where the proposed cutting clearly does not materially weaken the structure.

- B. Where authorized, cut opening through concrete (for pipe penetrations and similar services) by core drilling or sawing. Do not cut by hammer-driven chisel or drill.
- C. Other work: Do not endanger or damage other work through the procedures and processes of cutting to accommodate mechanical work. Review the proposed cutting with the Installer of the work to be cut, and comply with his recommendations to minimize damage. Where necessary, engage the original Installer or other specialists to execute the cutting in the recommended manner.
- D. Where patching is required to restore other work, because of either cutting or other damage inflicted during the installation of mechanical work, execute the patching in the manner recommended by the original Installer. Restore the other work in every respect, including the elimination of visual defects in exposed finishes, as judged by the Architect. Engage the original Installer to complete patching of the following categories of work:
 - 1. Exposed concrete finishes.
 - 2. Exposed masonry.
 - 3. Waterproofing and vapor barriers.
 - 4. Roofing, flashing and accessories.
 - 5. Interior exposed finishes and casework, where judged by the Architect to be difficult to achieve an acceptable match by other means.

3.03 COORDINATION OF MECHANICAL INSTALLATION

- A. General: Sequence, coordinate and integrate the various elements of mechanical work so that the mechanical plant will perform as indicated and be in harmony with the other work of the building. The Architect/Engineer will not supervise the coordination, which is the exclusive responsibility of the Contractor. Comply with the following requirements:
- B. Install piping, ductwork and similar services straight and true, aligned with other work and with overhead structures and allowing for insulation. Conceal where possible.
- C. Arrange work to facilitate maintenance and repair or replacement of equipment. Locate services requiring maintenance on valves and similar units in front of services requiring less maintenance. Connect equipment for ease of disconnecting, with minimum of interference with other work.
- D. Give the right-of way to piping systems required to slope for drainage (over other service lines).
- E. Piping shall be located to avoid interference with ductwork and light fixtures.
- F. Drawings: Conform with the arrangement indicated by the contract documents to the greatest extent possible, recognizing that portions of the work are shown only in diagrammatic form. Where coordination requirements conflict with individual system requirements, comply with the Architect's decision on resolution of the conflict.
- G. Electrical Work: Coordinate the mechanical work with electrical work, and properly interface with the electrical service. In general, and except as otherwise indicated, install mechanical equipment ready for electrical connection. Refer to the electrical sections of the specifications for electrical connection of mechanical equipment.
- H. Utility Connections: Coordinate the connection of mechanical systems with exterior underground utilities and services. Comply with the requirements of governing regulations, franchised service companies and controlling agencies. Provide a single connection for each service except where multiple connections are indicated.

3.04 COORDINATION OF MECHANICAL START-UP

- A. Seasonal Requirements: Adjust and coordinate the timing of mechanical system start-ups with seasonal variations, so that demonstration and testing of specified performance can be observed and recorded. Exercise proper care in off-season start-ups to ensure that systems and equipment will not be damaged by the operation.

- B. Painting and Air Distribution: Coordinate the initial cleaning and start-up of the HVAC air distribution system, to occur prior to preparatory cleaning and general interior painting and decorating on the project.

END OF SECTION

SECTION 230529
HANGERS AND SUPPORTS FOR HVAC PIPING AND EQUIPMENT

PART 1 GENERAL**1.01 RELATED DOCUMENTS**

- A. Drawings and general provisions of the Contract, including General and Supplementary Conditions and Division 01 Specification Sections, apply to this Section.

1.02 SUMMARY

- A. Section Includes:
1. Metal pipe hangers and supports.
 2. Trapeze pipe hangers.
 3. Metal framing systems.
 4. Thermal-hanger shield inserts.
 5. Fastener systems.
 6. Pipe stands.
 7. Equipment supports.
- B. Related Sections:
1. Section 055000 "Metal Fabrications" for structural-steel shapes and plates for trapeze hangers for pipe and equipment supports.
 2. Section 230516 "Expansion Fittings and Loops for HVAC Piping" for pipe guides and anchors.
 3. Section 230548 "Vibration and Seismic Controls for HVAC" for vibration isolation devices.
 4. Section 233113 "Metal Ducts" for duct hangers and supports.

1.03 DEFINITIONS

- A. MSS: Manufacturers Standardization Society of The Valve and Fittings Industry Inc.

1.04 PERFORMANCE REQUIREMENTS

- A. Delegated Design: Design trapeze pipe hangers and equipment supports, including comprehensive engineering analysis by a qualified professional engineer, using performance requirements and design criteria indicated.
- B. Structural Performance: Hangers and supports for HVAC piping and equipment shall withstand the effects of gravity loads and stresses within limits and under conditions indicated according to ASCE/SEI 7.
1. Design supports for multiple pipes, including pipe stands, capable of supporting combined weight of supported systems, system contents, and test water.
 2. Design equipment supports capable of supporting combined operating weight of supported equipment and connected systems and components.
 3. Design seismic-restraint hangers and supports for piping and equipment and obtain approval from authorities having jurisdiction.

1.05 ACTION SUBMITTALS

- A. Product Data: For each type of product indicated.
- B. Shop Drawings: Signed and sealed by a qualified professional engineer. Show fabrication and installation details and include calculations for the following; include Product Data for components:
1. Trapeze pipe hangers.
 2. Metal framing systems.
 3. Pipe stands.
 4. Equipment supports.

- C. Delegated-Design Submittal: For trapeze hangers indicated to comply with performance requirements and design criteria, including analysis data signed and sealed by the qualified professional engineer responsible for their preparation.
 - 1. Detail fabrication and assembly of trapeze hangers.
 - 2. Design Calculations: Calculate requirements for designing trapeze hangers.

1.06 INFORMATIONAL SUBMITTALS

- A. Welding certificates.

1.07 QUALITY ASSURANCE

- A. Structural Steel Welding Qualifications: Qualify procedures and personnel according to AWS D1.1/D1.1M, "Structural Welding Code - Steel."
- B. Pipe Welding Qualifications: Qualify procedures and operators according to ASME Boiler and Pressure Vessel Code.

PART 2 PRODUCTS

2.01 METAL PIPE HANGERS AND SUPPORTS

- A. Carbon-Steel Pipe Hangers and Supports
 - 1. Description: MSS SP-58, Types 1 through 58, factory-fabricated components.
 - 2. Galvanized Metallic Coatings: Pre-galvanized or hot dipped.
 - 3. Nonmetallic Coatings: Plastic coating, jacket, or liner.
 - 4. Padded Hangers: Hanger with fiberglass or other pipe insulation pad or cushion to support bearing surface of piping.
 - 5. Hanger Rods: Continuous-thread rod, nuts, and washer made of carbon steel.
- B. Stainless-Steel Pipe Hangers and Supports:
 - 1. Description: MSS SP-58, Types 1 through 58, factory-fabricated components.
 - 2. Padded Hangers: Hanger with fiberglass or other pipe insulation pad or cushion to support bearing surface of piping.
 - 3. Hanger Rods: Continuous-thread rod, nuts, and washer made of stainless steel.
- C. Copper Pipe Hangers:
 - 1. Description: MSS SP-58, Types 1 through 58, copper-coated-steel, factory-fabricated components.
 - 2. Hanger Rods: Continuous-thread rod, nuts, and washer made of copper-coated steel

2.02 TRAPEZE PIPE HANGERS

- A. Description: MSS SP-69, Type 59, shop- or field-fabricated pipe-support assembly made from structural carbon-steel shapes with MSS SP-58 carbon-steel hanger rods, nuts, saddles, and U-bolts.

2.03 METAL FRAMING SYSTEMS

- A. MFMA Manufacturer Metal Framing Systems:
 - 1. Description: Shop- or field-fabricated pipe-support assembly for supporting multiple parallel pipes.
 - 2. Standard: MFMA-4.
 - 3. Channels: Continuous slotted steel channel with in-turned lips.
 - 4. Channel Nuts: Formed or stamped steel nuts or other devices designed to fit into channel slot and, when tightened, prevent slipping along channel.
 - 5. Hanger Rods: Continuous-thread rod, nuts, and washer made of carbon steel.
 - 6. Metallic Coating: Hot-dipped galvanized.
- B. Non-MFMA Manufacturer Metal Framing Systems:
 - 1. Description: Shop- or field-fabricated pipe-support assembly made of steel channels, accessories, fittings, and other components for supporting multiple parallel pipes.
 - 2. Standard: Comply with MFMA-4.
 - 3. Channels: Continuous slotted steel channel with inturned lips.

4. Channel Nuts: Formed or stamped steel nuts or other devices designed to fit into channel slot and, when tightened, prevent slipping along channel.
5. Hanger Rods: Continuous-thread rod, nuts, and washer made of carbon steel.
6. Coating: Zinc.

2.04 THERMAL-HANGER SHIELD INSERTS

- A. Insulation-Insert Material for Cold Piping: ASTM C 552, Type II cellular glass with 100-psig minimum compressive strength and vapor barrier.
- B. Insulation-Insert Material for Hot Piping: ASTM C 552, Type II cellular glass with 100-psig minimum compressive strength.
- C. For Trapeze or Clamped Systems: Insert and shield shall cover entire circumference of pipe.
- D. For Clevis or Band Hangers: Insert and shield shall cover lower 180 degrees of pipe.
- E. Insert Length: Extend 2 inches beyond sheet metal shield for piping operating below ambient air temperature.

2.05 FASTENER SYSTEMS

- A. Powder-Actuated Fasteners: Threaded-steel stud, for use in hardened portland cement concrete with pull-out, tension, and shear capacities appropriate for supported loads and building materials where used.
- B. Mechanical-Expansion Anchors: Insert-wedge-type, steel anchors, for use in hardened portland cement concrete; with pull-out, tension, and shear capacities appropriate for supported loads and building materials where used.

2.06 PIPE STANDS

- A. General Requirements for Pipe Stands: Shop- or field-fabricated assemblies made of manufactured corrosion-resistant components to support roof-mounted piping.
- B. Compact Pipe Stand: One-piece plastic unit with integral-rod roller, pipe clamps, or V-shaped cradle to support pipe, for roof installation without membrane penetration.
- C. Low-Type, Single-Pipe Stand: One-piece plastic base unit with plastic roller, for roof installation without membrane penetration.
- D. Curb-Mounted-Type Pipe Stands: Shop- or field-fabricated pipe supports made from structural-steel shapes, continuous-thread rods, and rollers, for mounting on permanent stationary roof curb.

2.07 EQUIPMENT SUPPORTS

- A. Description: Welded, shop- or field-fabricated equipment support made from structural carbon-steel shapes.

2.08 MISCELLANEOUS MATERIALS

- A. Structural Steel: ASTM A 36/A 36M, carbon-steel plates, shapes, and bars; black and galvanized.
- B. Grout: ASTM C 1107, factory-mixed and -packaged, dry, hydraulic-cement, nonshrink and nonmetallic grout; suitable for interior and exterior applications.
 1. Properties: Nonstaining, noncorrosive, and nongaseous.
 2. Design Mix: 5000-psi, 28-day compressive strength.

PART 3 EXECUTION**3.01 HANGER AND SUPPORT INSTALLATION**

- A. Metal Pipe-Hanger Installation: Comply with MSS SP-69 and MSS SP-89. Install hangers, supports, clamps, and attachments as required to properly support piping from the building structure.

- B. Metal Trapeze Pipe-Hanger Installation: Comply with MSS SP-69 and MSS SP-89. Arrange for grouping of parallel runs of horizontal piping, and support together on field-fabricated trapeze pipe hangers.
 - 1. Pipes of Various Sizes: Support together and space trapezes for smallest pipe size or install intermediate supports for smaller diameter pipes as specified for individual pipe hangers.
 - 2. Field fabricate from ASTM A 36/A 36M, carbon-steel shapes selected for loads being supported. Weld steel according to AWS D1.1/D1.1M.
- C. Metal Framing System Installation: Arrange for grouping of parallel runs of piping, and support together on field-assembled metal framing systems.
- D. Thermal-Hanger Shield Installation: Install in pipe hanger or shield for insulated piping.
- E. Fastener System Installation:
 - 1. Install powder-actuated fasteners for use in lightweight concrete or concrete slabs less than 4 inches thick in concrete after concrete is placed and completely cured. Use operators that are licensed by powder-actuated tool manufacturer. Install fasteners according to powder-actuated tool manufacturer's operating manual.
 - 2. Install mechanical-expansion anchors in concrete after concrete is placed and completely cured. Install fasteners according to manufacturer's written instructions.
- F. Pipe Stand Installation:
 - 1. Pipe Stand Types except Curb-Mounted Type: Assemble components and mount on smooth roof surface. Do not penetrate roof membrane.
 - 2. Curb-Mounted-Type Pipe Stands: Assemble components or fabricate pipe stand and mount on permanent, stationary roof curb. See Section 077200 "Roof Accessories" for curbs.
- G. Install hangers and supports complete with necessary attachments, inserts, bolts, rods, nuts, washers, and other accessories.
- H. Equipment Support Installation: Fabricate from welded-structural-steel shapes.
- I. Install hangers and supports to allow controlled thermal and seismic movement of piping systems, to permit freedom of movement between pipe anchors, and to facilitate action of expansion joints, expansion loops, expansion bends, and similar units.
- J. Install lateral bracing with pipe hangers and supports to prevent swaying.
- K. Install building attachments within concrete slabs or attach to structural steel. Install additional attachments at concentrated loads, including valves, flanges, and strainers, NPS 2-1/2 and larger and at changes in direction of piping. Install concrete inserts before concrete is placed; fasten inserts to forms and install reinforcing bars through openings at top of inserts.
- L. Load Distribution: Install hangers and supports so that piping live and dead loads and stresses from movement will not be transmitted to connected equipment.
- M. Pipe Slopes: Install hangers and supports to provide indicated pipe slopes and to not exceed maximum pipe deflections allowed by ASME B31.9 for building services piping.
- N. Insulated Piping:
 - 1. Attach clamps and spacers to piping.
 - a. Piping Operating above Ambient Air Temperature: Clamp may project through insulation.
 - b. Piping Operating below Ambient Air Temperature: Use thermal-hanger shield insert with clamp sized to match OD of insert.
 - c. Do not exceed pipe stress limits allowed by ASME B31.9 for building services piping.
 - 2. Install MSS SP-58, Type 39, protection saddles if insulation without vapor barrier is indicated. Fill interior voids with insulation that matches adjoining insulation.
 - a. Option: Thermal-hanger shield inserts may be used. Include steel weight-distribution plate for pipe NPS 4 and larger if pipe is installed on rollers.

3. Install MSS SP-58, Type 40, protective shields on cold piping with vapor barrier. Shields shall span an arc of 180 degrees.
 - a. Option: Thermal-hanger shield inserts may be used. Include steel weight-distribution plate for pipe NPS 4 and larger if pipe is installed on rollers.
4. Shield Dimensions for Pipe: Not less than the following:
 - a. NPS 1/4 to NPS 3-1/2: 12 inches long and 0.048 inch thick.
5. Thermal-Hanger Shields: Install with insulation same thickness as piping insulation.

3.02 EQUIPMENT SUPPORTS

- A. Fabricate structural-steel stands to suspend equipment from structure overhead or to support equipment above floor.
- B. Grouting: Place grout under supports for equipment and make bearing surface smooth.
- C. Provide lateral bracing, to prevent swaying, for equipment supports.

3.03 METAL FABRICATIONS

- A. Cut, drill, and fit miscellaneous metal fabrications for trapeze pipe hangers and equipment supports.
- B. Fit exposed connections together to form hairline joints. Field weld connections that cannot be shop welded because of shipping size limitations.
- C. Field Welding: Comply with AWS D1.1/D1.1M procedures for shielded, metal arc welding; appearance and quality of welds; and methods used in correcting welding work; and with the following:
 1. Use materials and methods that minimize distortion and develop strength and corrosion resistance of base metals.
 2. Obtain fusion without undercut or overlap.
 3. Remove welding flux immediately.
 4. Finish welds at exposed connections so no roughness shows after finishing and so contours of welded surfaces match adjacent contours.

3.04 ADJUSTING

- A. Hanger Adjustments: Adjust hangers to distribute loads equally on attachments and to achieve indicated slope of pipe.
- B. Trim excess length of continuous-thread hanger and support rods to **1-1/2 inches**.

3.05 HANGER AND SUPPORT SCHEDULE

- A. Specific hanger and support requirements are in Sections specifying piping systems and equipment.
- B. Comply with MSS SP-69 for pipe-hanger selections and applications that are not specified in piping system Sections.
- C. Use hangers and supports with galvanized metallic coatings for piping and equipment that will not have field-applied finish.
- D. Use nonmetallic coatings on attachments for electrolytic protection where attachments are in direct contact with copper tubing.
- E. Use carbon-steel pipe hangers and supports and metal framing systems and attachments for general service applications.
- F. Use stainless-steel pipe hangers and stainless-steel or corrosion-resistant attachments for hostile environment applications.
- G. Use copper-plated pipe hangers and copper or stainless-steel attachments for copper piping and tubing.
- H. Use padded hangers for piping that is subject to scratching.
- I. Use thermal-hanger shield inserts for insulated piping and tubing.

- J. Horizontal-Piping Hangers and Supports: Unless otherwise indicated and except as specified in piping system Sections, install the following types:
1. Adjustable, Steel Clevis Hangers (MSS Type 1): For suspension of non-insulated or insulated, stationary pipes NPS 1/2 to NPS 30.
- K. Vertical-Piping Clamps: Unless otherwise indicated and except as specified in piping system Sections, install the following types:
1. Extension Pipe or Riser Clamps (MSS Type 8): For support of pipe risers NPS 3/4 to NPS 24.
- L. Hanger-Rod Attachments: Unless otherwise indicated and except as specified in piping system Sections, install the following types:
1. Steel Turnbuckles (MSS Type 13): For adjustment up to 6 inches for heavy loads.
 2. Steel Clevises (MSS Type 14): For 120 to 450 deg F piping installations.
 3. Swivel Turnbuckles (MSS Type 15): For use with MSS Type 11, split pipe rings.
 4. Malleable-Iron Sockets (MSS Type 16): For attaching hanger rods to various types of building attachments.
 5. Steel Weldless Eye Nuts (MSS Type 17): For 120 to 450 deg F piping installations.
- M. Building Attachments: Unless otherwise indicated and except as specified in piping system Sections, install the following types:
1. Steel or Malleable Concrete Inserts (MSS Type 18): For upper attachment to suspend pipe hangers from concrete ceiling.
 2. Top-Beam C-Clamps (MSS Type 19): For use under roof installations with bar-joint construction, to attach to top flange of structural shape.
 3. Side-Beam or Channel Clamps (MSS Type 20): For attaching to bottom flange of beams, channels, or angles.
 4. Center-Beam Clamps (MSS Type 21): For attaching to center of bottom flange of beams.
 5. Welded Beam Attachments (MSS Type 22): For attaching to bottom of beams if loads are considerable and rod sizes are large.
 6. C-Clamps (MSS Type 23): For structural shapes.
 7. Top-Beam Clamps (MSS Type 25): For top of beams if hanger rod is required tangent to flange edge.
 8. Side-Beam Clamps (MSS Type 27): For bottom of steel I-beams.
 9. Steel-Beam Clamps with Eye Nuts (MSS Type 28): For attaching to bottom of steel I-beams for heavy loads.
 10. Linked-Steel Clamps with Eye Nuts (MSS Type 29): For attaching to bottom of steel I-beams for heavy loads, with link extensions.
 11. Malleable-Beam Clamps with Extension Pieces (MSS Type 30): For attaching to structural steel.
 12. Welded-Steel Brackets: For support of pipes from below or for suspending from above by using clip and rod. Use one of the following for indicated loads:
 - a. Light (MSS Type 31): 750 lb.
 - b. Medium (MSS Type 32): 1500 lb.
 - c. Heavy (MSS Type 33): 3000 lb.
 13. Side-Beam Brackets (MSS Type 34): For sides of steel or wooden beams.
 14. Plate Lugs (MSS Type 57): For attaching to steel beams if flexibility at beam is required.
 15. Horizontal Travelers (MSS Type 58): For supporting piping systems subject to linear horizontal movement where headroom is limited.
- O. Saddles and Shields: Unless otherwise indicated and except as specified in piping system Sections, install the following types:
1. Steel-Pipe-Covering Protection Saddles (MSS Type 39): To fill interior voids with insulation that matches adjoining insulation.
 2. Protection Shields (MSS Type 40): Of length recommended in writing by manufacturer to prevent crushing insulation.

3. Thermal-Hanger Shield Inserts: For supporting insulated pipe.
- P. Spring Hangers and Supports: Unless otherwise indicated and except as specified in piping system Sections, install the following types:
1. Restraint-Control Devices (MSS Type 47): Where indicated to control piping movement.
 2. Spring Cushions (MSS Type 48): For light loads if vertical movement does not exceed 1-1/4 inches.
 3. Spring-Cushion Roll Hangers (MSS Type 49): For equipping Type 41, roll hanger with springs.
 4. Spring Sway Braces (MSS Type 50): To retard sway, shock, vibration, or thermal expansion in piping systems.
 5. Variable-Spring Hangers (MSS Type 51): Preset to indicated load and limit variability factor to 25 percent to allow expansion and contraction of piping system from hanger.
 6. Variable-Spring Base Supports (MSS Type 52): Preset to indicated load and limit variability factor to 25 percent to allow expansion and contraction of piping system from base support.
 7. Variable-Spring Trapeze Hangers (MSS Type 53): Preset to indicated load and limit variability factor to 25 percent to allow expansion and contraction of piping system from trapeze support.
 8. Constant Supports: For critical piping stress and if necessary to avoid transfer of stress from one support to another support, critical terminal, or connected equipment. Include auxiliary stops for erection, hydrostatic test, and load-adjustment capability. These supports include the following types:
 - a. Horizontal (MSS Type 54): Mounted horizontally.
 - b. Vertical (MSS Type 55): Mounted vertically.
 - c. Trapeze (MSS Type 56): Two vertical-type supports and one trapeze member.
- Q. Comply with MSS SP-69 for trapeze pipe-hanger selections and applications that are not specified in piping system Sections.
- R. Comply with MFMA-103 for metal framing system selections and applications that are not specified in piping system Sections.
- S. Use powder-actuated fasteners or mechanical-expansion anchors instead of building attachments where required in concrete construction.

END OF SECTION

SECTION 23 05 48**VIBRATION AND SEISMIC CONTROLS FOR HVAC****PART 1 GENERAL****1.01 RELATED DOCUMENTS**

- A. Drawings and general provisions of the Contract, including General and Supplementary Conditions and Division 01 Specification Sections, apply to this Section.

1.02 SUMMARY

- A. Section Includes:
 - 1. Elastomeric isolation pads.
 - 2. Elastomeric isolation mounts.
 - 3. Restrained elastomeric isolation mounts.
 - 4. Open-spring isolators.
 - 5. Housed-spring isolators.
 - 6. Restrained-spring isolators.
 - 7. Housed-restrained-spring isolators.
 - 8. Pipe-riser resilient supports.
 - 9. Resilient pipe guides.
 - 10. Elastomeric hangers.
 - 11. Spring hangers.
 - 12. Snubbers.
 - 13. Restraint channel bracings.
 - 14. Restraint cables.
 - 15. Seismic-restraint accessories.
 - 16. Mechanical anchor bolts.
 - 17. Adhesive anchor bolts.
- B. Related Requirements:
 - 1. Section 220548 "Vibration and Seismic Controls for Plumbing" for devices for plumbing equipment and systems.

1.03 DEFINITIONS

- A. IBC: International Building Code.
- B. ICC-ES: ICC-Evaluation Service.
- C. OSHPD: Office of Statewide Health Planning & Development (for the State of California).

1.04 ACTION SUBMITTALS

- A. Product Data: For each type of product.
 - 1. Include rated load, rated deflection, and overload capacity for each vibration isolation device.
 - 2. Illustrate and indicate style, material, strength, fastening provision, and finish for each type and size of vibration isolation device and seismic-restraint component required.
 - a. Tabulate types and sizes of seismic restraints, complete with report numbers and rated strength in tension and shear as evaluated by an evaluation service member of ICC-ES or OSHPD or an agency acceptable to authorities having jurisdiction.
 - b. Annotate to indicate application of each product submitted and compliance with requirements.
 - 3. Interlocking Snubbers: Include ratings for horizontal, vertical, and combined loads.
- B. Shop Drawings:
 - 1. Detail fabrication and assembly of equipment bases. Detail fabrication including anchorages and attachments to structure and to supported equipment. Include adjustable motor bases, rails, and frames for equipment mounting.
 - 2. Vibration Isolation Base Details: Detail fabrication including anchorages and attachments to structure and to supported equipment. Include adjustable motor

- bases, rails, and frames for equipment mounting.
- C. Delegated-Design Submittal: For each vibration isolation and seismic-restraint device.
1. Include design calculations and details for selecting vibration isolators, seismic restraints, and vibration isolation bases complying with performance requirements, design criteria, and analysis data signed and sealed by the qualified professional engineer responsible for their preparation.
 2. Design Calculations: Calculate static and dynamic loading due to equipment weight, operation, and seismic and wind forces required to select vibration isolators and seismic and wind restraints and for designing vibration isolation bases.
 - a. Coordinate design calculations with wind load calculations required for equipment mounted outdoors. Comply with requirements in other Sections for equipment mounted outdoors.
 3. Riser Supports: Include riser diagrams and calculations showing anticipated expansion and contraction at each support point, initial and final loads on building structure, spring deflection changes, and seismic loads. Include certification that riser system was examined for excessive stress and that none exists.
 4. Seismic- and Wind-Restraint Details:
 - a. Design Analysis: To support selection and arrangement of seismic and wind restraints. Include calculations of combined tensile and shear loads.
 - b. Details: Indicate fabrication and arrangement. Detail attachments of restraints to the restrained items and to the structure. Show attachment locations, methods, and spacings. Identify components, list their strengths, and indicate directions and values of forces transmitted to the structure during seismic events. Indicate association with vibration isolation devices.
 - c. Coordinate seismic-restraint and vibration isolation details with wind-restraint details required for equipment mounted outdoors. Comply with requirements in other Sections for equipment mounted outdoors.
 - d. Preapproval and Evaluation Documentation: By an evaluation service member of ICC-ES or OSHPD or an agency acceptable to authorities having jurisdiction, showing maximum ratings of restraint items and the basis for approval (tests or calculations).

1.05 INFORMATIONAL SUBMITTALS

- A. Coordination Drawings: Show coordination of vibration isolation device installation and seismic bracing for HVAC piping and equipment with other systems and equipment in the vicinity, including other supports and restraints, if any.
- B. Qualification Data: For professional engineer and testing agency.
- C. Welding certificates.
- D. Field quality-control reports.

1.06 CLOSEOUT SUBMITTALS

- A. Operation and Maintenance Data

1.07 QUALITY ASSURANCE

- A. Testing Agency Qualifications: An independent agency, with the experience and capability to conduct the testing indicated, that is an NRTL as defined by OSHA in 29 CFR 1910.7 and that is acceptable to authorities having jurisdiction.
- B. Comply with seismic-restraint requirements in the IBC unless requirements in this Section are more stringent.
- C. Welding Qualifications: Qualify procedures and personnel according to AWS D1.1/D1.1M, "Structural Welding Code - Steel."
- D. Seismic-restraint devices shall have horizontal and vertical load testing and analysis and shall bear anchorage preapproval OPA number from OSHPD, preapproval by ICC-ES, or preapproval by another agency acceptable to authorities having jurisdiction, showing

maximum seismic-restraint ratings. Ratings based on independent testing are preferred to ratings based on calculations. If preapproved ratings are unavailable, submittals based on independent testing are preferred. Calculations (including combining shear and tensile loads) to support seismic-restraint designs must be signed and sealed by a qualified professional engineer.

PART 2 - PRODUCTS

2.01 ELASTOMERIC ISOLATION PADS

- A. Elastomeric Isolation Pads:
 - 1. Manufacturers: Subject to compliance with requirements, available manufacturers offering products that may be incorporated into the Work include, but are not limited to, the following:
 - a. Ace Mountings Co., Inc.
 - b. California Dynamics Corporation.
 - c. Isolation Technology, Inc.
 - d. Kinetics Noise Control, Inc.
 - e. Mason Industries, Inc.
 - f. Vibration Eliminator Co., Inc.
 - g. Vibration Isolation.
 - h. Vibration Mountings & Controls, Inc.
 - 2. Fabrication: Single or multiple layers of sufficient durometer stiffness for uniform loading over pad area.
 - 3. Size: Factory or field cut to match requirements of supported equipment.
 - 4. Pad Material: Oil and water resistant with elastomeric properties.
 - 5. Surface Pattern: Smooth or Ribbed or Waffle pattern.
 - 6. Infused nonwoven cotton or synthetic fibers.
 - 7. Load-bearing metal plates adhered to pads.
 - 8. Sandwich-Core Material: Resilient and elastomeric.
 - a. Surface Pattern: Smooth or Ribbed or Waffle pattern.
 - b. Infused nonwoven cotton or synthetic fibers.

2.02 ELASTOMERIC ISOLATION MOUNTS

- A. Double-Deflection, Elastomeric Isolation Mounts:
 - 1. Manufacturers: Subject to compliance with requirements, available manufacturers offering products that may be incorporated into the Work include, but are not limited to, the following:
 - a. Ace Mountings Co., Inc.
 - b. California Dynamics Corporation.
 - c. Isolation Technology, Inc.
 - d. Kinetics Noise Control, Inc.
 - e. Mason Industries, Inc.
 - f. Vibration Eliminator Co., Inc.
 - g. Vibration Isolation.
 - h. Vibration Mountings & Controls, Inc.
 - 2. Mounting Plates:
 - a. Top Plate: Encapsulated steel load transfer top plates, factory drilled and threaded with threaded studs or bolts.
 - b. Baseplate: Encapsulated steel bottom plates with holes provided for anchoring to support structure.
 - 3. Elastomeric Material: Molded, oil-resistant rubber, neoprene, or other elastomeric material.

2.03 RESTRAINED ELASTOMERIC ISOLATION MOUNTS

- A. Restrained Elastomeric Isolation Mounts:
 - 1. Manufacturers: Subject to compliance with requirements, available manufacturers offering products that may be incorporated into the Work include, but are not limited to, the following:
 - a. Ace Mountings Co., Inc.

- b. California Dynamics Corporation.
 - c. Isolation Technology, Inc.
 - d. Kinetics Noise Control, Inc.
 - e. Mason Industries, Inc.
 - f. Vibration Eliminator Co., Inc.
 - g. Vibration Isolation.
 - h. Vibration Mountings & Controls, Inc.
2. Description: All-directional isolator with seismic restraints containing two separate and opposing elastomeric elements that prevent central threaded element and attachment hardware from contacting the housing during normal operation.
- a. Housing: Cast-ductile iron or welded steel.
 - b. Elastomeric Material: Molded, oil-resistant rubber, neoprene, or other elastomeric material.

2.04 OPEN-SPRING ISOLATORS

- A. Freestanding, Laterally Stable, Open-Spring Isolators:
1. Manufacturers: Subject to compliance with requirements, available manufacturers offering products that may be incorporated into the Work include, but are not limited to, the following:
 - a. Ace Mountings Co., Inc.
 - b. California Dynamics Corporation.
 - c. Isolation Technology, Inc.
 - d. Kinetics Noise Control, Inc.
 - e. Mason Industries, Inc.
 - f. Vibration Eliminator Co., Inc.
 - g. Vibration Isolation.
 - h. Vibration Mountings & Controls, Inc.
 2. Outside Spring Diameter: Not less than 80 percent of the compressed height of the spring at rated load.
 3. Minimum Additional Travel: 50 percent of the required deflection at rated load.
 4. Lateral Stiffness: More than 80 percent of rated vertical stiffness.
 5. Overload Capacity: Support 200 percent of rated load, fully compressed, without deformation or failure.
 6. Baseplates: Factory-drilled steel plate for bolting to structure with an elastomeric isolator pad attached to the underside. Baseplates shall limit floor load to 500 psig.
 7. Top Plate and Adjustment Bolt: Threaded top plate with adjustment bolt and cap screw to fasten and level equipment.

2.05 HOUSED-SPRING ISOLATORS

- A. Freestanding, Laterally Stable, Open-Spring Isolators in Two-Part Telescoping Housing:
1. Manufacturers: Subject to compliance with requirements, available manufacturers offering products that may be incorporated into the Work include, but are not limited to, the following:
 - a. Ace Mountings Co., Inc.
 - b. California Dynamics Corporation.
 - c. Isolation Technology, Inc.
 - d. Kinetics Noise Control, Inc.
 - e. Mason Industries, Inc.
 - f. Vibration Eliminator Co., Inc.
 - g. Vibration Isolation.
 - h. Vibration Mountings & Controls, Inc.
 2. Outside Spring Diameter: Not less than 80 percent of the compressed height of the spring at rated load.
 3. Minimum Additional Travel: 50 percent of the required deflection at rated load.
 4. Lateral Stiffness: More than 80 percent of rated vertical stiffness.
 5. Overload Capacity: Support 200 percent of rated load, fully compressed, without deformation or failure.

6. Two-Part Telescoping Housing: A steel top and bottom frame separated by an elastomeric material and enclosing the spring isolators.
 - a. Drilled base housing for bolting to structure with an elastomeric isolator pad attached to the underside. Bases shall limit floor load to 500 psig.
 - b. Top housing with attachment and leveling bolt or threaded mounting holes and internal leveling device or elastomeric pad.

2.06 RESTRAINED-SPRING ISOLATORS

- A. Freestanding, Laterally Stable, Open-Spring Isolators with Vertical-Limit Stop Restraint:
 1. Manufacturers: Subject to compliance with requirements, available manufacturers offering products that may be incorporated into the Work include, but are not limited to, the following:
 - a. Ace Mountings Co., Inc.
 - b. California Dynamics Corporation.
 - c. Isolation Technology, Inc.
 - d. Kinetics Noise Control, Inc.
 - e. Mason Industries, Inc.
 - f. Vibration Eliminator Co., Inc.
 - g. Vibration Isolation.
 - h. Vibration Mountings & Controls, Inc.
 2. Housing: Steel housing with vertical-limit stops to prevent spring extension due to weight being removed.
 - a. Base with holes for bolting to structure with an elastomeric isolator pad attached to the underside. Bases shall limit floor load to 500 psig.
 - b. Top plate with threaded mounting holes or elastomeric pad.
 - c. Internal leveling bolt that acts as blocking during installation.
 3. Restraint: Limit stop as required for equipment and authorities having jurisdiction.
 4. Outside Spring Diameter: Not less than 80 percent of the compressed height of the spring at rated load.
 5. Minimum Additional Travel: 50 percent of the required deflection at rated load.
 6. Lateral Stiffness: More than 80 percent of rated vertical stiffness.
 7. Overload Capacity: Support 200 percent of rated load, fully compressed, without deformation or failure.

2.07 HOUSED-RESTRAINED-SPRING ISOLATORS

- A. Freestanding, Steel, Open-Spring Isolators with Vertical-Limit Stop Restraint in Two-Part Telescoping Housing:
 1. Manufacturers: Subject to compliance with requirements, available manufacturers offering products that may be incorporated into the Work include, but are not limited to, the following:
 - a. Ace Mountings Co., Inc.
 - b. California Dynamics Corporation.
 - c. Isolation Technology, Inc.
 - d. Kinetics Noise Control, Inc.
 - e. Mason Industries, Inc.
 - f. Vibration Eliminator Co., Inc.
 - g. Vibration Isolation.
 - h. Vibration Mountings & Controls, Inc.
 2. Two-Part Telescoping Housing: A steel top and bottom frame separated by an elastomeric material and enclosing the spring isolators. Housings are equipped with adjustable or non-adjustable snubbers to limit vertical movement.
 - a. Drilled base housing for bolting to structure with an elastomeric isolator pad attached to the underside. Bases shall limit floor load to 500 psig.
 - b. Threaded top housing with adjustment bolt and cap screw to fasten and level equipment.
 3. Outside Spring Diameter: Not less than 80 percent of the compressed height of the spring at rated load.
 4. Minimum Additional Travel: 50 percent of the required deflection at rated load.

5. Lateral Stiffness: More than 80 percent of rated vertical stiffness.
6. Overload Capacity: Support 200 percent of rated load, fully compressed, without deformation or failure.

2.08 PIPE-RISER RESILIENT SUPPORT

- A. Description: All-directional, acoustical pipe anchor consisting of two steel tubes separated by a minimum 1/2-inch- thick neoprene.
1. Vertical-Limit Stops: Steel and neoprene vertical-limit stops arranged to prevent vertical travel in both directions.
 2. Maximum Load Per Support: 500 psig on isolation material providing equal isolation in all directions.

2.09 RESILIENT PIPE GUIDES

- A. Description: Telescopic arrangement of two steel tubes or post and sleeve arrangement separated by a minimum 1/2-inch- thick neoprene.
1. Factory-Set Height Guide with Shear Pin: Shear pin shall be removable and reinsertable to allow for selection of pipe movement. Guides shall be capable of motion to meet location requirements.

2.10 ELASTOMERIC HANGERS

- A. Elastomeric Mount in a Steel Frame with Upper and Lower Steel Hanger Rods:
1. Manufacturers: Subject to compliance with requirements, available manufacturers offering products that may be incorporated into the Work include, but are not limited to, the following:
 - a. Ace Mountings Co., Inc.
 - b. California Dynamics Corporation.
 - c. Isolation Technology, Inc.
 - d. Kinetics Noise Control, Inc.
 - e. Mason Industries, Inc.
 - f. Vibration Eliminator Co., Inc.
 - g. Vibration Mountings & Controls, Inc.
 2. Frame: Steel, fabricated with a connection for an upper threaded hanger rod and an opening on the underside to allow for a maximum of 30 degrees of angular lower hanger-rod misalignment without binding or reducing isolation efficiency.
 3. Dampening Element: Molded, oil-resistant rubber, neoprene, or other elastomeric material with a projecting bushing for the underside opening preventing steel to steel contact.

2.11 SPRING HANGERS

- A. Combination Coil-Spring and Elastomeric-Insert Hanger with Spring and Insert in Compression:
1. Manufacturers: Subject to compliance with requirements, available manufacturers offering products that may be incorporated into the Work include, but are not limited to, the following:
 - a. Ace Mountings Co., Inc.
 - b. California Dynamics Corporation.
 - c. Kinetics Noise Control, Inc.
 - d. Mason Industries, Inc.
 - e. Vibration Eliminator Co., Inc.
 - f. Vibration Isolation.
 - g. Vibration Mountings & Controls, Inc.
 2. Frame: Steel, fabricated for connection to threaded hanger rods and to allow for a maximum of 30 degrees of angular hanger-rod misalignment without binding or reducing isolation efficiency.
 3. Outside Spring Diameter: Not less than 80 percent of the compressed height of the spring at rated load.
 4. Minimum Additional Travel: 50 percent of the required deflection at rated load.
 5. Lateral Stiffness: More than 80 percent of rated vertical stiffness.

6. Overload Capacity: Support 200 percent of rated load, fully compressed, without deformation or failure.
7. Elastomeric Element: Molded, oil-resistant rubber or neoprene. Steel-washer-reinforced cup to support spring and bushing projecting through bottom of frame.
8. Adjustable Vertical Stop: Steel washer with neoprene washer "up-stop" on lower threaded rod.
9. Self-centering hanger-rod cap to ensure concentricity between hanger rod and support spring coil.

2.12 SNUBBERS

- A. Manufacturers: Subject to compliance with requirements, available manufacturers offering products that may be incorporated into the Work include, but are not limited to, the following:
 1. Kinetics Noise Control, Inc.
 2. Mason Industries, Inc.
 3. Vibration Mountings & Controls, Inc.
- B. Description: Factory fabricated using welded structural-steel shapes and plates, anchor bolts, and replaceable resilient isolation washers and bushings.
 1. Anchor bolts for attaching to concrete shall be seismic-rated, drill-in, and stud-wedge or female-wedge type.
 2. Resilient Isolation Washers and Bushings: Oil- and water-resistant neoprene.
 3. Maximum 1/4-inch air gap, and minimum 1/4-inch- thick resilient cushion.

2.13 RESTRAINT CHANNEL BRACINGS

- A. Manufacturers: Subject to compliance with requirements, available manufacturers offering products that may be incorporated into the Work include, but are not limited to, the following:
 1. Cooper B-Line, Inc.
 2. Hilti, Inc.
 3. Mason Industries, Inc.
 4. Unistrut.
- B. Description: MFMA-4, shop- or field-fabricated bracing assembly made of slotted steel channels with accessories for attachment to braced component at one end and to building structure at the other end and other matching components and with corrosion-resistant coating; rated in tension, compression, and torsion forces.

2.14 RESTRAINT CABLES

- A. Manufacturers: Subject to compliance with requirements, available manufacturers offering products that may be incorporated into the Work include, but are not limited to, the following:
 1. Kinetics Noise Control, Inc.
 2. Loos & Co., Inc.
 3. Vibration Mountings & Controls, Inc.
- B. Restraint Cables: ASTM A 603 galvanized or ASTM A 492 stainless-steel cables. End connections made of steel assemblies with thimbles, brackets, swivel, and bolts designed for restraining cable service; with a minimum of two clamping bolts for cable engagement.

2.15 SEISMIC-RESTRAINT ACCESSORIES

- A. Manufacturers: Subject to compliance with requirements, available manufacturers offering products that may be incorporated into the Work include, but are not limited to, the following:
 1. Cooper B-Line, Inc.
 2. Kinetics Noise Control, Inc.
 3. Mason Industries, Inc.
 4. TOLCO.
- B. Hanger-Rod Stiffener: Steel tube or steel slotted-support-system sleeve with internally bolted connections or Reinforcing steel angle clamped to hanger rod.

- C. Hinged and Swivel Brace Attachments: Multifunctional steel connectors for attaching hangers to rigid channel bracings and restraint cables.
- D. Bushings for Floor-Mounted Equipment Anchor Bolts: Neoprene bushings designed for rigid equipment mountings, and matched to type and size of anchor bolts and studs.
- E. Bushing Assemblies for Wall-Mounted Equipment Anchorage: Assemblies of neoprene elements and steel sleeves designed for rigid equipment mountings, and matched to type and size of attachment devices used.
- F. Resilient Isolation Washers and Bushings: One-piece, molded, oil- and water-resistant neoprene, with a flat washer face.

2.16 MECHANICAL ANCHOR BOLTS

- A. Manufacturers: Subject to compliance with requirements, available manufacturers offering products that may be incorporated into the Work include, but are not limited to, the following:
 - 1. Cooper B-Line, Inc.
 - 2. Hilti, Inc.
 - 3. Kinetics Noise Control, Inc.
 - 4. Mason Industries, Inc.
- B. Mechanical Anchor Bolts: Drilled-in and stud-wedge or female-wedge type in zinc-coated steel for interior applications and stainless steel for exterior applications. Select anchor bolts with strength required for anchor and as tested according to ASTM E 488.

2.17 ADHESIVE ANCHOR BOLTS

- A. Manufacturers: Subject to compliance with requirements, available manufacturers offering products that may be incorporated into the Work include, but are not limited to, the following:
 - 1. Hilti, Inc.
 - 2. Kinetics Noise Control, Inc.
 - 3. Mason Industries, Inc.
- B. Adhesive Anchor Bolts: Drilled-in and capsule anchor system containing PVC or urethane methacrylate-based resin and accelerator, or injected polymer or hybrid mortar adhesive. Provide anchor bolts and hardware with zinc-coated steel for interior applications and stainless steel for exterior applications. Select anchor bolts with strength required for anchor and as tested according to ASTM E 488.

2.18 VIBRATION ISOLATION EQUIPMENT BASES

- A. Manufacturers: Subject to compliance with requirements, available manufacturers offering products that may be incorporated into the Work include, but are not limited to, the following:
 - 1. California Dynamics Corporation.
 - 2. Kinetics Noise Control.
 - 3. Mason Industries, Inc.
 - 4. Vibration Eliminator Co., Inc.
 - 5. Vibration Isolation.
 - 6. Vibration Mountings & Controls, Inc.
- B. Steel Rails: Factory-fabricated, welded, structural-steel rails.
 - 1. Design Requirements: Lowest possible mounting height with not less than 1-inch clearance above the floor. Include equipment anchor bolts and auxiliary motor slide rails.
 - a. Include supports for suction and discharge elbows for pumps.
 - 2. Structural Steel: Steel shapes, plates, and bars complying with ASTM A 36/A 36M. Rails shall have shape to accommodate supported equipment.
 - 3. Support Brackets: Factory-welded steel brackets on frame for outrigger isolation mountings and to provide for anchor bolts and equipment support.
- C. Steel Bases: Factory-fabricated, welded, structural-steel bases and rails.
 - 1. Design Requirements: Lowest possible mounting height with not less than 1-inch

- clearance above the floor. Include equipment anchor bolts and auxiliary motor slide bases or rails.
- a. Include supports for suction and discharge elbows for pumps.
 2. Structural Steel: Steel shapes, plates, and bars complying with ASTM A 36/A 36M. Bases shall have shape to accommodate supported equipment.
 3. Support Brackets: Factory-welded steel brackets on frame for outrigger isolation mountings and to provide for anchor bolts and equipment support.
- D. Concrete Inertia Base: Factory-fabricated or field-fabricated, welded, structural-steel bases and rails ready for placement of cast-in-place concrete.
1. Design Requirements: Lowest possible mounting height with not less than 1-inch clearance above the floor. Include equipment anchor bolts and auxiliary motor slide bases or rails.
 - a. Include supports for suction and discharge elbows for pumps.
 2. Structural Steel: Steel shapes, plates, and bars complying with ASTM A 36/A 36M. Bases shall have shape to accommodate supported equipment.
 3. Support Brackets: Factory-welded steel brackets on frame for outrigger isolation mountings and to provide for anchor bolts and equipment support.
 4. Fabrication: Fabricate steel templates to hold equipment anchor-bolt sleeves and anchors in place during placement of concrete. Obtain anchor-bolt templates from supported equipment manufacturer.

PART 3 - EXECUTION

3.01 EXAMINATION

- A. Examine areas and equipment to receive vibration isolation and seismic- and wind-control devices for compliance with requirements for installation tolerances and other conditions affecting performance of the Work.
- B. Examine roughing-in of reinforcement and cast-in-place anchors to verify actual locations before installation.
- C. Proceed with installation only after unsatisfactory conditions have been corrected.

3.02 APPLICATIONS

- A. Multiple Pipe Supports: Secure pipes to trapeze member with clamps approved for application by an evaluation service member of ICC-ES or OSHPD or an agency acceptable to authorities having jurisdiction.
- B. Hanger-Rod Stiffeners: Install hanger-rod stiffeners where indicated or scheduled on Drawings to receive them and where required to prevent buckling of hanger rods due to seismic forces.
- C. Strength of Support and Seismic-Restraint Assemblies: Where not indicated, select sizes of components so strength is adequate to carry present and future static and seismic loads within specified loading limits.

3.03 VIBRATION CONTROL AND SEISMIC-RESTRAINT DEVICE INSTALLATION

- A. Coordinate the location of embedded connection hardware with supported equipment attachment and mounting points and with requirements for concrete reinforcement and formwork specified in Section 033000 "Cast-in-Place Concrete." Section 033053 "Miscellaneous Cast-in-Place Concrete."
- B. Installation of vibration isolators must not cause any change of position of equipment, piping, or ductwork resulting in stresses or misalignment.
- C. Equipment Restraints:
 1. Install seismic snubbers on HVAC equipment mounted on vibration isolators. Locate snubbers as close as possible to vibration isolators and bolt to equipment base and supporting structure.
 2. Install resilient bolt isolation washers on equipment anchor bolts where clearance between anchor and adjacent surface exceeds 0.125 inch.
 3. Install seismic-restraint devices using methods approved by an evaluation service member of ICC-ES or OSHPD or an agency acceptable to authorities

having jurisdiction that provides required submittals for component.

- D. Piping Restraints:
 - 1. Comply with requirements in MSS SP-127.
 - 2. Space lateral supports a maximum of 40 feet o.c., and longitudinal supports a maximum of 80 feet o.c.
 - 3. Brace a change of direction longer than 12 feet.
- E. Install cables so they do not bend across edges of adjacent equipment or building structure.
- F. Install seismic-restraint devices using methods approved by an evaluation service member of ICC-ES or OSHPD or an agency acceptable to authorities having jurisdiction that provides required submittals for component.
- G. Install bushing assemblies for anchor bolts for floor-mounted equipment, arranged to provide resilient media between anchor bolt and mounting hole in concrete base.
- H. Install bushing assemblies for mounting bolts for wall-mounted equipment, arranged to provide resilient media where equipment or equipment-mounting channels are attached to wall.
- I. Attachment to Structure: If specific attachment is not indicated, anchor bracing to structure at flanges of beams, at upper truss chords of bar joists, or at concrete members.
- J. Drilled-in Anchors:
 - 1. Identify position of reinforcing steel and other embedded items prior to drilling holes for anchors. Do not damage existing reinforcing or embedded items during coring or drilling. Notify the structural engineer if reinforcing steel or other embedded items are encountered during drilling. Locate and avoid prestressed tendons, electrical and telecommunications conduit, and gas lines.
 - 2. Do not drill holes in concrete or masonry until concrete, mortar, or grout has achieved full design strength.
 - 3. Wedge Anchors: Protect threads from damage during anchor installation. Heavy-duty sleeve anchors shall be installed with sleeve fully engaged in the structural element to which anchor is to be fastened.
 - 4. Adhesive Anchors: Clean holes to remove loose material and drilling dust prior to installation of adhesive. Place adhesive in holes proceeding from the bottom of the hole and progressing toward the surface in such a manner as to avoid introduction of air pockets in the adhesive.
 - 5. Set anchors to manufacturer's recommended torque, using a torque wrench.
 - 6. Install zinc-coated steel anchors for interior and stainless-steel anchors for exterior applications.

3.04 ACCOMMODATION OF DIFFERENTIAL SEISMIC MOTION

- A. Install flexible connections in piping where they cross seismic joints, where adjacent sections or branches are supported by different structural elements, and where the connections terminate with connection to equipment that is anchored to a different structural element from the one supporting the connections as they approach equipment. Comply with requirements in Section 232113 "Hydronic Piping" for piping flexible connections.

3.05 FIELD QUALITY CONTROL

- A. Testing Agency: Engage a qualified testing agency to perform tests and inspections.
- B. Perform tests and inspections.
- C. Tests and Inspections:
 - 1. Provide evidence of recent calibration of test equipment by a testing agency acceptable to authorities having jurisdiction.
 - 2. Schedule test with Owner, through Architect, before connecting anchorage device to restrained component (unless post connection testing has been approved), and with at least seven days' advance notice.

3. Obtain Architect's approval before transmitting test loads to structure. Provide temporary load-spreading members.
 4. Test at least four of each type and size of installed anchors and fasteners selected by Architect.
 5. Test to 90 percent of rated proof load of device.
 6. Measure isolator restraint clearance.
 7. Measure isolator deflection.
 8. Verify snubber minimum clearances.
- D. Remove and replace malfunctioning units and retest as specified above.
- E. Prepare test and inspection reports.

3.06 ADJUSTING

- A. Adjust isolators after piping system is at operating weight.
- B. Adjust limit stops on restrained-spring isolators to mount equipment at normal operating height. After equipment installation is complete, adjust limit stops so they are out of contact during normal operation.

END OF SECTION

SECTION 23 05 53**IDENTIFICATION FOR HVAC PIPING AND EQUIPMENT****PART 1 GENERAL****1.01 RELATED DOCUMENTS**

- A. Drawings and general provisions of the Contract, including General and Supplementary Conditions and Division 01 Specification Sections, apply to this Section.

1.02 SUMMARY

- A. Section Includes:
 - 1. Equipment labels.
 - 2. Warning signs and labels.
 - 3. Pipe labels.
 - 4. Stencils.
 - 5. Warning tags.

1.03 ACTION SUBMITTALS

- A. Product Data: For each type of product indicated.
- B. Samples: For color, letter style, and graphic representation required for each identification material and device.
- C. Equipment Label Schedule: Include a listing of all equipment to be labeled with the proposed content for each label.
- D. Valve numbering scheme.
- E. Valve Schedules: For each piping system to include in maintenance manuals.

1.04 COORDINATION

- A. Coordinate installation of identifying devices with completion of covering and painting of surfaces where devices are to be applied.
- B. Coordinate installation of identifying devices with locations of access panels and doors.
- C. Install identifying devices before installing acoustical ceilings and similar concealment.

PART 2 PRODUCTS**2.01 EQUIPMENT LABELS**

- A. Metal Labels for Equipment:
 - 1. Material and Thickness: Stainless steel, 0.025-inch, Aluminum, 0.032-inch and having predrilled or stamped holes for attachment hardware.
 - 2. Minimum Label Size: Length and width vary for required label content, but not less than 2-1/2 by 3/4 inch.
 - 3. Minimum Letter Size: 1/4 inch for name of units if viewing distance is less than 24 inches, 1/2 inch for viewing distances up to 72 inches, and proportionately larger lettering for greater viewing distances. Include secondary lettering two-thirds to three-fourths the size of principal lettering.
 - 4. Fasteners: Stainless-steel rivets or self-tapping screws.
 - 5. Adhesive: Contact-type permanent adhesive, compatible with label and with substrate.
- B. Label Content: Include equipment's Drawing designation or unique equipment number, Drawing numbers where equipment is indicated (plans, details, and schedules), plus the Specification Section number and title where equipment is specified.
- C. Equipment Label Schedule: For each item of equipment to be labeled, on 8-1/2-by-11-inch bond paper. Tabulate equipment identification number and identify Drawing numbers where equipment is indicated (plans, details, and schedules), plus the Specification Section number and title where equipment is specified. Equipment schedule shall be included in operation and maintenance data.

2.02 WARNING SIGNS AND LABELS

- A. Material and Thickness: Multilayer, multicolor, plastic labels for mechanical engraving, 1/8 inch thick, and having predrilled holes for attachment hardware.
- B. Letter Color: Black.
- C. Background Color: White.
- D. Maximum Temperature: Able to withstand temperatures up to 160 deg F.
- E. Minimum Label Size: Length and width vary for required label content, but not less than 2-1/2 by 3/4 inch.
- F. Minimum Letter Size: 1/4 inch for name of units if viewing distance is less than 24 inches, 1/2 inch for viewing distances up to 72 inches, and proportionately larger lettering for greater viewing distances. Include secondary lettering two-thirds to three-fourths the size of principal lettering.
- G. Fasteners: Stainless-steel rivets or self-tapping screws.
- H. Adhesive: Contact-type permanent adhesive, compatible with label and with substrate.
- I. Label Content: Include caution and warning information, plus emergency notification instructions.

2.03 PIPE LABELS

- A. General Requirements for Manufactured Pipe Labels: Preprinted, color-coded, with lettering indicating service, and showing flow direction.
- B. Pretensioned Pipe Labels: Pre-coiled, semirigid plastic formed to cover full circumference of pipe and to attach to pipe without fasteners or adhesive.
- C. Self-Adhesive Pipe Labels: Printed plastic with contact-type, permanent-adhesive backing.
- D. Pipe Label Contents: Include identification of piping service using same designations or abbreviations as used on Drawings, pipe size, and an arrow indicating flow direction.
 - 1. Flow-Direction Arrows: Integral with piping system service lettering to accommodate both directions, or as separate unit on each pipe label to indicate flow direction.
 - 2. Lettering Size: At least 1-1/2 inches high.

2.04 STENCILS

- A. Stencils: Prepared with letter sizes according to ASME A13.1 for piping; minimum letter height of 1-1/4 inches for ducts; and minimum letter height of 3/4 inch for access panel and door labels, equipment labels, and similar operational instructions.
 - 1. Stencil Material: Aluminum, Brass, Fiberboard, or metal.
 - 2. Stencil Paint: Exterior, gloss, alkyd enamel or acrylic enamel black unless otherwise indicated. Paint may be in pressurized spray-can form.
 - 3. Identification Paint: Exterior, alkyd enamel or acrylic enamel in colors according to ASME A13.1 unless otherwise indicated.

2.05 WARNING TAGS

- A. Warning Tags: Preprinted or partially preprinted, accident-prevention tags, of plasticized card stock with matte finish suitable for writing.
 - 1. Size: 3 by 5-1/4 inches minimum, Approximately 4 by 7 inches.
 - 2. Fasteners: Brass grommet and wire.
 - 3. Nomenclature: Large-size primary caption such as "DANGER," "CAUTION," or "DO NOT OPERATE."
 - 4. Color: Yellow background with black lettering.

PART 3 EXECUTION**3.01 PREPARATION**

- A. Clean piping and equipment surfaces of substances that could impair bond of

identification devices, including dirt, oil, grease, release agents, and incompatible primers, paints, and encapsulants.

3.02 EQUIPMENT LABEL INSTALLATION

- A. Install or permanently fasten labels on each major item of mechanical equipment.
- B. Locate equipment labels where accessible and visible.

3.03 PIPE LABEL INSTALLATION

- A. Piping Color-Coding: Painting of piping is specified in Section 099123 "Interior Painting" Section 099600 "High Performance Coatings"
- B. Stenciled Pipe Label Option: Stenciled labels may be provided instead of manufactured pipe labels, at Installer's option. Install stenciled pipe labels with painted, color-coded bands or rectangles, complying with ASME A13.1, on each piping system.
 - 1. Identification Paint: Use for contrasting background.
 - 2. Stencil Paint: Use for pipe marking.
- C. Locate pipe labels where piping is exposed or above accessible ceilings in finished spaces; machine rooms; accessible maintenance spaces such as shafts, tunnels, and plenums; and exterior exposed locations as follows:
 - 1. Near each valve and control device.
 - 2. Near each branch connection, excluding short takeoffs for fixtures and terminal units. Where flow pattern is not obvious, mark each pipe at branch.
 - 3. Near penetrations through walls, floors, ceilings, and inaccessible enclosures.
 - 4. At access doors, manholes, and similar access points that permit view of concealed piping.
 - 5. Near major equipment items and other points of origination and termination.
 - 6. Spaced at maximum intervals of 50 feet along each run. Reduce intervals to 25 feet in areas of congested piping and equipment.
 - 7. On piping above removable acoustical ceilings. Omit intermediately spaced labels.
- D. Pipe Label Color Schedule:
 - 1. Refrigerant Piping:
 - a. Background Color: Orange.
 - b. Letter Color: Black.
 - 2. Condensate Piping:
 - a. Background Color: Green.
 - b. Letter Color: White.

3.04 WARNING-TAG INSTALLATION

- A. Write required message on, and attach warning tags to, equipment and other items where required.

END OF SECTION

SECTION 23 05 93**TESTING, ADJUSTING, AND BALANCING FOR HVAC****PART 1 GENERAL****1.01 RELATED DOCUMENTS**

- A. Drawings and general provisions of the Contract, including General and Supplementary Conditions and Division 01 Specification Sections, apply to this Section.

1.02 SUMMARY

- A. Section Includes:
 - 1. Balancing Air Systems:
 - a. Constant-volume air systems.

1.03 DEFINITIONS

- A. AABC: Associated Air Balance Council.
- B. NEBB: National Environmental Balancing Bureau.
- C. TAB: Testing, adjusting, and balancing.
- D. TABB: Testing, Adjusting, and Balancing Bureau.
- E. TAB Specialist: An entity engaged to perform TAB Work.

1.04 INFORMATIONAL SUBMITTALS

- A. Qualification Data: Within 30 days of Contractor's Notice to Proceed, submit documentation that the TAB contractor and this Project's TAB team members meet the qualifications specified in "Quality Assurance" Article.
- B. Contract Documents Examination Report: Within 30 days of Contractor's Notice to Proceed, submit the Contract Documents review report as specified in Part 3.
- C. Strategies and Procedures Plan: Within 30 days of Contractor's Notice to Proceed, submit TAB strategies and step-by-step procedures as specified in "Preparation" Article.
- D. Certified TAB reports.
- E. Sample report forms.
- F. Instrument calibration reports, to include the following:
 - 1. Instrument type and make.
 - 2. Serial number.
 - 3. Application.
 - 4. Dates of use.
 - 5. Dates of calibration.

1.05 QUALITY ASSURANCE

- A. TAB Contractor Qualifications: Engage a TAB entity certified by AABC, NEBB, or TABB.
 - 1. TAB Field Supervisor: Employee of the TAB contractor and certified by AABC, NEBB, or TABB.
 - 2. TAB Technician: Employee of the TAB contractor and who is certified by AABC, NEBB, or TABB as a TAB technician.
- B. TAB Conference: Meet with Architect, Owner, Construction Manager, or Commissioning Authority on approval of the TAB strategies and procedures plan to develop a mutual understanding of the details. Require the participation of the TAB field supervisor and technicians. Provide seven days' advance notice of scheduled meeting time and location.
 - 1. Agenda Items:
 - a. The Contract Documents examination report.
 - b. The TAB plan.
 - c. Coordination and cooperation of trades and subcontractors.
 - d. Coordination of documentation and communication flow.

- C. Certify TAB field data reports and perform the following:
 - 1. Review field data reports to validate accuracy of data and to prepare certified TAB reports.
 - 2. Certify that the TAB team complied with the approved TAB plan and the procedures specified and referenced in this Specification.
- D. TAB Report Forms: Use standard TAB contractor's forms approved by Architect, Owner, Construction Manager, or Commissioning Authority.
- E. Instrumentation Type, Quantity, Accuracy, and Calibration: As described in ASHRAE 111, Section 5, "Instrumentation."
- F. ASHRAE Compliance: Applicable requirements in ASHRAE 62.1, Section 7.2.2 - "Air Balancing."
- G. ASHRAE/IESNA Compliance: Applicable requirements in ASHRAE/IESNA 90.1, Section 6.7.2.3 - "System Balancing."

1.06 PROJECT CONDITIONS

- A. Full Owner Occupancy: Owner will occupy the site and existing building during entire TAB period. Cooperate with Owner during TAB operations to minimize conflicts with Owner's operations.
- B. Partial Owner Occupancy: Owner may occupy completed areas of building before Substantial Completion. Cooperate with Owner during TAB operations to minimize conflicts with Owner's operations.

1.07 COORDINATION

- A. Notice: Provide seven days' advance notice for each test. Include scheduled test dates and times.
- B. Perform TAB after leakage and pressure tests on air distribution systems have been satisfactorily completed.

PART 2 - PRODUCTS (Not Applicable)

PART 3 - EXECUTION

3.01 EXAMINATION

- A. Examine the Contract Documents to become familiar with Project requirements and to discover conditions in systems' designs that may preclude proper TAB of systems and equipment.
- B. Examine systems for installed balancing devices, such as test ports, gage cocks, thermometer wells, flow-control devices, balancing valves and fittings, and manual volume dampers. Verify that locations of these balancing devices are accessible.
- C. Examine the approved submittals for HVAC systems and equipment.
- D. Examine design data including HVAC system descriptions, statements of design assumptions for environmental conditions and systems' output, and statements of philosophies and assumptions about HVAC system and equipment controls.
- E. Examine ceiling plenums and underfloor air plenums used for supply, as specified in Section 233113 "Metal Ducts" Section 233116 "Nonmetal Ducts" and are properly separated from adjacent areas. Verify that penetrations in plenum walls are sealed and fire-stopped if required.
- F. Examine equipment performance data including fan curves.
 - 1. Relate performance data to Project conditions and requirements, including system effects that can create undesired or unpredicted conditions that cause reduced capacities in all or part of a system.
 - 2. Calculate system-effect factors to reduce performance ratings of HVAC equipment when installed under conditions different from the conditions used to rate equipment performance. To calculate system effects for air systems, use tables and charts found in AMCA 201, "Fans and Systems," or in SMACNA's

"HVAC Systems - Duct Design." Compare results with the design data and installed conditions.

- G. Examine system and equipment installations and verify that field quality-control testing, cleaning, and adjusting specified in individual Sections have been performed.
- H. Examine test reports specified in individual system and equipment Sections.
- I. Examine HVAC equipment and filters and verify that bearings are greased, belts are aligned and tight, and equipment with functioning controls is ready for operation.
- J. Examine strainers. Verify that startup screens are replaced by permanent screens with indicated perforations.
- K. Examine heat-transfer coils for correct piping connections and for clean and straight fins.
- L. Examine operating safety interlocks and controls on HVAC equipment.
- M. Report deficiencies discovered before and during performance of TAB procedures. Observe and record system reactions to changes in conditions. Record default set points if different from indicated values.

3.02 PREPARATION

- A. Prepare a TAB plan that includes strategies and step-by-step procedures.
- B. Complete system-readiness checks and prepare reports. Verify the following:
 1. Permanent electrical-power wiring is complete.
 2. Automatic temperature-control systems are operational.
 3. Equipment and duct access doors are securely closed.
 4. Balance, smoke, and fire dampers are open.
 5. Isolating and balancing valves are open and control valves are operational.
 6. Ceilings are installed in critical areas where air-pattern adjustments are required and access to balancing devices is provided.
 7. Windows and doors can be closed so indicated conditions for system operations can be met.

3.03 GENERAL PROCEDURES FOR TESTING AND BALANCING

- A. Perform testing and balancing procedures on each system according to the procedures contained in AABC's "National Standards for Total System Balance", ASHRAE 111, NEBB's "Procedural Standards for Testing, Adjusting, and Balancing of Environmental Systems", SMACNA's "HVAC Systems - Testing, Adjusting, and Balancing" and in this Section.
 1. Comply with requirements in ASHRAE 62.1, Section 7.2.2 - "Air Balancing."
- B. Cut insulation, ducts, pipes, and equipment cabinets for installation of test probes to the minimum extent necessary for TAB procedures.
 1. After testing and balancing, patch probe holes in ducts with same material and thickness as used to construct ducts.
 2. After testing and balancing, install test ports and duct access doors that comply with requirements in Section 233300 "Air Duct Accessories."
 3. Install and join new insulation that matches removed materials. Restore insulation, coverings, vapor barrier, and finish according to Section 230713 "Duct Insulation," Section 230716 "HVAC Equipment Insulation," and Section 230719 "HVAC Piping Insulation."
- C. Mark equipment and balancing devices, including damper-control positions, valve position indicators, fan-speed-control levers, and similar controls and devices, with paint or other suitable, permanent identification material to show final settings.
- D. Take and report testing and balancing measurements in inch-pound (IP) units.

3.04 GENERAL PROCEDURES FOR BALANCING AIR SYSTEMS

- A. Prepare test reports for both fans and outlets. Obtain manufacturer's outlet factors and recommended testing procedures. Crosscheck the summation of required outlet volumes with required fan volumes.

- B. Prepare schematic diagrams of systems' "as-built" duct layouts.
- C. Determine the best locations in main and branch ducts for accurate duct-airflow measurements.
- D. Check airflow patterns from the outdoor-air louvers and dampers and the return- and exhaust-air dampers through the supply-fan discharge and mixing dampers.
- E. Locate start-stop and disconnect switches, electrical interlocks, and motor starters.
- F. Verify that motor starters are equipped with properly sized thermal protection.
- G. Check dampers for proper position to achieve desired airflow path.
- H. Check for airflow blockages.
- I. Check condensate drains for proper connections and functioning.
- J. Check for proper sealing of air-handling-unit components.
- K. Verify that air duct system is sealed as specified in Section 233113 "Metal Ducts."

3.05 PROCEDURES FOR CONSTANT-VOLUME AIR SYSTEMS

- A. Adjust fans to deliver total indicated airflows within the maximum allowable fan speed listed by fan manufacturer.
 - 1. Measure total airflow.
 - a. Where sufficient space in ducts is unavailable for Pitot-tube traverse measurements, measure airflow at terminal outlets and inlets and calculate the total airflow.
 - 2. Measure fan static pressures as follows to determine actual static pressure:
 - a. Measure outlet static pressure as far downstream from the fan as practical and upstream from restrictions in ducts such as elbows and transitions.
 - b. Measure static pressure directly at the fan outlet or through the flexible connection.
 - c. Measure inlet static pressure of single-inlet fans in the inlet duct as near the fan as possible, upstream from the flexible connection, and downstream from duct restrictions.
 - d. Measure inlet static pressure of double-inlet fans through the wall of the plenum that houses the fan.
 - 3. Measure static pressure across each component that makes up an air-handling unit, rooftop unit, and other air-handling and -treating equipment.
 - a. Report the cleanliness status of filters and the time static pressures are measured.
 - 4. Measure static pressures entering and leaving other devices, such as sound traps, heat-recovery equipment, and air washers, under final balanced conditions.
 - 5. Review Record Documents to determine variations in design static pressures versus actual static pressures. Calculate actual system-effect factors. Recommend adjustments to accommodate actual conditions.
 - 6. Obtain approval from Architect, Owner, Construction Manager, or Commissioning Authority for adjustment of fan speed higher or lower than indicated speed. Comply with requirements in HVAC Sections for air-handling units for adjustment of fans, belts, and pulley sizes to achieve indicated air-handling-unit performance.
 - 7. Do not make fan-speed adjustments that result in motor overload. Consult equipment manufacturers about fan-speed safety factors. Modulate dampers and measure fan-motor amperage to ensure that no overload will occur. Measure amperage in full-cooling, full-heating, economizer, and any other operating mode to determine the maximum required brake horsepower.
- B. Adjust volume dampers for main duct, submain ducts, and major branch ducts to indicated airflows within specified tolerances.

1. Measure airflow of submain and branch ducts.
 - a. Where sufficient space in submain and branch ducts is unavailable for Pitot-tube traverse measurements, measure airflow at terminal outlets and inlets and calculate the total airflow for that zone.
 2. Measure static pressure at a point downstream from the balancing damper, and adjust volume dampers until the proper static pressure is achieved.
 3. Remeasure each submain and branch duct after all have been adjusted. Continue to adjust submain and branch ducts to indicated airflows within specified tolerances.
- C. Measure air outlets and inlets without making adjustments.
1. Measure terminal outlets using a direct-reading hood or outlet manufacturer's written instructions and calculating factors.
- D. Adjust air outlets and inlets for each space to indicated airflows within specified tolerances of indicated values. Make adjustments using branch volume dampers rather than extractors and the dampers at air terminals.
1. Adjust each outlet in same room or space to within specified tolerances of indicated quantities without generating noise levels above the limitations prescribed by the Contract Documents.
 2. Adjust patterns of adjustable outlets for proper distribution without drafts.

3.06 PROCEDURES FOR MOTORS

- A. Motors, 1/2 HP and Larger: Test at final balanced conditions and record the following data:
1. Manufacturer's name, model number, and serial number.
 2. Motor horsepower rating.
 3. Motor rpm.
 4. Efficiency rating.
 5. Nameplate and measured voltage, each phase.
 6. Nameplate and measured amperage, each phase.
 7. Starter thermal-protection-element rating.

3.07 PROCEDURES FOR CONDENSING UNITS

- A. Verify proper rotation of fans.
- B. Measure entering- and leaving-air temperatures.
- C. Record compressor data.

3.08 PROCEDURES FOR HEAT-TRANSFER COILS

- A. Measure, adjust, and record the following data for each electric heating coil:
1. Nameplate data.
 2. Airflow.
 3. Entering- and leaving-air temperature at full load.
 4. Voltage and amperage input of each phase at full load and at each incremental stage.
 5. Calculated kilowatt at full load.
 6. Fuse or circuit-breaker rating for overload protection.
- B. Measure, adjust, and record the following data for each refrigerant coil:
1. Dry-bulb temperature of entering and leaving air.
 2. Wet-bulb temperature of entering and leaving air.
 3. Airflow.
 4. Air pressure drop.
 5. Refrigerant suction pressure and temperature.

3.09 TOLERANCES

- A. Set HVAC system's air flow rates within the following tolerances:
1. Supply, Return, and Exhaust Fans and Equipment with Fans: Plus or minus 10 percent.

2. Air Outlets and Inlets: Plus or minus 10 percent.

3.10 REPORTING

- A. Initial Construction-Phase Report: Based on examination of the Contract Documents as specified in "Examination" Article, prepare a report on the adequacy of design for systems' balancing devices. Recommend changes and additions to systems' balancing devices to facilitate proper performance measuring and balancing. Recommend changes and additions to HVAC systems and general construction to allow access for performance measuring and balancing devices.
- B. Status Reports: Prepare biweekly progress reports to describe completed procedures, procedures in progress, and scheduled procedures. Include a list of deficiencies and problems found in systems being tested and balanced. Prepare a separate report for each system and each building floor for systems serving multiple floors.

3.11 FINAL REPORT

- A. General: Prepare a certified written report; tabulate and divide the report into separate sections for tested systems and balanced systems.
 1. Include a certification sheet at the front of the report's binder, signed and sealed by the certified testing and balancing engineer.
 2. Include a list of instruments used for procedures, along with proof of calibration.
- B. Final Report Contents: In addition to certified field-report data, include the following:
 1. Fan curves.
 2. Manufacturers' test data.
 3. Field test reports prepared by system and equipment installers.
 4. Other information relative to equipment performance; do not include Shop Drawings and product data.
- C. General Report Data: In addition to form titles and entries, include the following data:
 1. Title page.
 2. Name and address of the TAB contractor.
 3. Project name.
 4. Project location.
 5. Architect's name and address.
 6. Engineer's name and address.
 7. Contractor's name and address.
 8. Report date.
 9. Signature of TAB supervisor who certifies the report.
 10. Table of Contents with the total number of pages defined for each section of the report. Number each page in the report.
 11. Summary of contents including the following:
 - a. Indicated versus final performance.
 - b. Notable characteristics of systems.
 - c. Description of system operation sequence if it varies from the Contract Documents.
 12. Nomenclature sheets for each item of equipment.
 13. Data for terminal units, including manufacturer's name, type, size, and fittings.
 14. Notes to explain why certain final data in the body of reports vary from indicated values.
 15. Test conditions for fan performance forms including the following:
 - a. Settings for outdoor-, return-, and exhaust-air dampers.
 - b. Conditions of filters.
 - c. Cooling coil, wet- and dry-bulb conditions.
 - d. Face and bypass damper settings at coils.
 - e. Fan drive settings including settings and percentage of maximum pitch diameter.
 - f. Settings for supply-air, static-pressure controller.
 - g. Other system operating conditions that affect performance.

- D. System Diagrams: Include schematic layouts of air distribution systems. Present each system with single-line diagram and include the following:
1. Quantities of outdoor, supply, return, and exhaust airflows.
 2. Duct, outlet, and inlet sizes.
 3. Terminal units.
 4. Balancing stations.
 5. Position of balancing devices.
- E. Air-Handling-Unit Test Reports: For air-handling units with coils, include the following:
1. Unit Data:
 - a. Unit identification.
 - b. Location.
 - c. Make and type.
 - d. Model number and unit size.
 - e. Manufacturer's serial number.
 - f. Unit arrangement and class.
 - g. Discharge arrangement.
 - h. Sheave make, size in inches, and bore.
 - i. Center-to-center dimensions of sheave, and amount of adjustments in inches.
 - j. Number, make, and size of belts.
 - k. Number, type, and size of filters.
 2. Motor Data:
 - a. Motor make, and frame type and size.
 - b. Horsepower and rpm.
 - c. Volts, phase, and hertz.
 - d. Full-load amperage and service factor.
 - e. Sheave make, size in inches, and bore.
 - f. Center-to-center dimensions of sheave, and amount of adjustments in inches.
 3. Test Data (Indicated and Actual Values):
 - a. Total air flow rate in cfm.
 - b. Total system static pressure in inches wg.
 - c. Fan rpm.
 - d. Discharge static pressure in inches wg.
 - e. Filter static-pressure differential in inches wg.
 - f. Preheat-coil static-pressure differential in inches wg.
 - g. Cooling-coil static-pressure differential in inches wg.
 - h. Heating-coil static-pressure differential in inches wg.
 - i. Outdoor airflow in cfm.
 - j. Return airflow in cfm.
 - k. Outdoor-air damper position.
 - l. Return-air damper position.
 - m. Vortex damper position.
- F. Apparatus-Coil Test Reports:
1. Coil Data:
 - a. System identification.
 - b. Location.
 - c. Coil type.
 - d. Number of rows.
 - e. Fin spacing in fins per inch o.c.
 - f. Make and model number.
 - g. Face area in sq. ft.
 - h. Tube size in NPS.
 - i. Tube and fin materials.
 - j. Circuiting arrangement.
 2. Test Data (Indicated and Actual Values):

- a. Air flow rate in cfm.
 - b. Average face velocity in fpm.
 - c. Air pressure drop in inches wg.
 - d. Outdoor-air, wet- and dry-bulb temperatures in deg F.
 - e. Return-air, wet- and dry-bulb temperatures in deg F.
 - f. Entering-air, wet- and dry-bulb temperatures in deg F.
 - g. Leaving-air, wet- and dry-bulb temperatures in deg F.
 - h. Refrigerant expansion valve and refrigerant types.
 - i. Refrigerant suction pressure in psig.
 - j. Refrigerant suction temperature in deg F.
 - k. Inlet steam pressure in psig.
- G. Electric-Coil Test Reports: For electric furnaces, duct coils, and electric coils installed in central-station air-handling units, include the following:
- 1. Unit Data:
 - a. System identification.
 - b. Location.
 - c. Coil identification.
 - d. Capacity in Btu/h.
 - e. Number of stages.
 - f. Connected volts, phase, and hertz.
 - g. Rated amperage.
 - h. Air flow rate in cfm.
 - i. Face area in sq. ft..
 - j. Minimum face velocity in fpm.
 - 2. Test Data (Indicated and Actual Values):
 - a. Heat output in Btu/h.
 - b. Air flow rate in cfm.
 - c. Air velocity in fpm.
 - d. Entering-air temperature in deg F.
 - e. Leaving-air temperature in deg F.
 - f. Voltage at each connection.
 - g. Amperage for each phase.
- H. Fan Test Reports: For supply, return, and exhaust fans, include the following:
- 1. Fan Data:
 - a. System identification.
 - b. Location.
 - c. Make and type.
 - d. Model number and size.
 - e. Manufacturer's serial number.
 - f. Arrangement and class.
 - g. Sheave make, size in inches, and bore.
 - h. Center-to-center dimensions of sheave, and amount of adjustments in inches.
 - 2. Motor Data:
 - a. Motor make, and frame type and size.
 - b. Horsepower and rpm.
 - c. Volts, phase, and hertz.
 - d. Full-load amperage and service factor.
 - e. Sheave make, size in inches, and bore.
 - f. Center-to-center dimensions of sheave, and amount of adjustments in inches.
 - g. Number, make, and size of belts.
 - 3. Test Data (Indicated and Actual Values):
 - a. Total airflow rate in cfm.
 - b. Total system static pressure in inches wg.
 - c. Fan rpm.

- d. Discharge static pressure in inches wg.
- e. Suction static pressure in inches wg.
- I. Round and Rectangular Duct Traverse Reports: Include a diagram with a grid representing the duct cross-section and record the following:
 - 1. Report Data:
 - a. System and air-handling-unit number.
 - b. Location and zone.
 - c. Traverse air temperature in deg F.
 - d. Duct static pressure in inches wg.
 - e. Duct size in inches.
 - f. Duct area in sq. ft..
 - g. Indicated air flow rate in cfm.
 - h. Indicated velocity in fpm.
 - i. Actual air flow rate in cfm.
 - j. Actual average velocity in fpm.
 - k. Barometric pressure in psig.
- J. System-Coil Reports: For reheat coils include the following:
 - 1. Unit Data:
 - a. System and air-handling-unit identification.
 - b. Location and zone.
 - c. Room or riser served.
 - d. Coil make and size.
 - e. Flowmeter type.
 - 2. Test Data (Indicated and Actual Values):
 - a. Air flow rate in cfm.
 - b. Entering-air temperature in deg F.
 - c. Leaving-air temperature in deg F.
- K. Instrument Calibration Reports:
 - 1. Report Data:
 - a. Instrument type and make.
 - b. Serial number.
 - c. Application.
 - d. Dates of use.
 - e. Dates of calibration.

3.12 INSPECTIONS

- A. Initial Inspection:
 - 1. After testing and balancing are complete, operate each system and randomly check measurements to verify that the system is operating according to the final test and balance readings documented in the final report.
 - 2. Check the following for each system:
 - a. Measure airflow of at least 10 percent of air outlets.
 - b. Measure room temperature at each thermostat/temperature sensor. Compare the reading to the set point.
 - c. Verify that balancing devices are marked with final balance position.
 - d. Note deviations from the Contract Documents in the final report.
- B. Final Inspection:
 - 1. After initial inspection is complete and documentation by random checks verifies that testing and balancing are complete and accurately documented in the final report, request that a final inspection be made by Architect, Owner, Construction Manager, or Commissioning Authority.
 - 2. The TAB contractor's test and balance engineer shall conduct the inspection in the presence of Architect, Owner, Construction Manager, or Commissioning Authority shall randomly select measurements, documented in the final report, to be rechecked. Rechecking shall be limited to either 10 percent of the total

- measurements recorded or the extent of measurements that can be accomplished in a normal 8-hour business day.
3. If rechecks yield measurements that differ from the measurements documented in the final report by more than the tolerances allowed, the measurements shall be noted as "FAILED."
 4. If the number of "FAILED" measurements is greater than 10 percent of the total measurements checked during the final inspection, the testing and balancing shall be considered incomplete and shall be rejected.
- C. TAB Work will be considered defective if it does not pass final inspections. If TAB Work fails, proceed as follows:
1. Recheck all measurements and make adjustments. Revise the final report and balancing device settings to include all changes; resubmit the final report and request a second final inspection.
 2. If the second final inspection also fails, Owner may contract the services of another TAB contractor to complete TAB Work according to the Contract Documents and deduct the cost of the services from the original TAB contractor's final payment.
- D. Prepare test and inspection reports.

3.13 ADDITIONAL TESTS

- A. Within 90 days of completing TAB, perform additional TAB to verify that balanced conditions are being maintained throughout and to correct unusual conditions.
- B. Seasonal Periods: If initial TAB procedures were not performed during near-peak summer and winter conditions, perform additional TAB during near-peak summer and winter conditions.

END OF SECTION

SECTION 23 07 13
DUCT INSULATION

PART 1 GENERAL**1.01 RELATED DOCUMENTS**

- A. Drawings and general provisions of the Contract, including General and Supplementary Conditions and Division 01 Specification Sections, apply to this Section.

1.02 SUMMARY

- A. Section includes insulating the following duct services:
1. Indoor, concealed supply and outdoor air.
 2. Indoor, concealed return located in unconditioned space.
 3. Indoor, concealed exhaust between isolation damper and penetration of building exterior.
- B. Related Sections:
1. Section 230719 "HVAC Piping Insulation."
 2. Section 233113 "Metal Ducts" for duct liners.

1.03 ACTION SUBMITTALS

- A. Product Data: For each type of product indicated. Include thermal conductivity, water-vapor permeance thickness, and jackets (both factory- and field-applied if any).
- B. Shop Drawings: Include plans, elevations, sections, details, and attachments to other work.
1. Detail application of protective shields, saddles, and inserts at hangers for each type of insulation and hanger.
 2. Detail insulation application at elbows, fittings, dampers, specialties and flanges for each type of insulation.
 3. Detail application of field-applied jackets.
 4. Detail application at linkages of control devices.

1.04 INFORMATIONAL SUBMITTALS

- A. Qualification Data: For qualified Installer.
- B. Material Test Reports: From a qualified testing agency acceptable to authorities having jurisdiction indicating, interpreting, and certifying test results for compliance of insulation materials, sealers, attachments, cements, and jackets, with requirements indicated. Include dates of tests and test methods employed.
- C. Field quality-control reports.

1.05 QUALITY ASSURANCE

- A. Installer Qualifications: Skilled mechanics who have successfully completed an apprenticeship program or another craft training program certified by the Department of Labor, Bureau of Apprenticeship and Training.
- B. Surface-Burning Characteristics: For insulation and related materials, as determined by testing identical products according to ASTM E 84, by a testing agency acceptable to authorities having jurisdiction. Factory label insulation and jacket materials and adhesive, mastic, tapes, and cement material containers, with appropriate markings of applicable testing agency.
1. Insulation Installed Indoors: Flame-spread index of 25 or less, and smoke-developed index of 50 or less.
 2. Insulation Installed Outdoors: Flame-spread index of 75 or less, and smoke-developed index of 150 or less.

1.06 DELIVERY, STORAGE, AND HANDLING

- A. Packaging: Insulation material containers shall be marked by manufacturer with appropriate ASTM standard designation, type and grade, and maximum use temperature.

1.07 COORDINATION

- A. Coordinate sizes and locations of supports, hangers, and insulation shields specified in Section 230529 "Hangers and Supports for HVAC Piping and Equipment."
- B. Coordinate clearance requirements with duct Installer for duct insulation application. Before preparing ductwork Shop Drawings, establish and maintain clearance requirements for installation of insulation and field-applied jackets and finishes and for space required for maintenance.
- C. Coordinate installation and testing of heat tracing.

1.08 SCHEDULING

- A. Schedule insulation application after pressure testing systems and, where required, after installing and testing heat tracing. Insulation application may begin on segments that have satisfactory test results.
- B. Complete installation and concealment of plastic materials as rapidly as possible in each area of construction.

PART 2 PRODUCTS

2.01 INSULATION MATERIALS

- A. Comply with requirements in "Duct Insulation Schedule, General," "Indoor Duct and Plenum Insulation Schedule," and "Aboveground, Outdoor Duct and Plenum Insulation Schedule" articles for where insulating materials shall be applied.
- B. Products shall not contain asbestos, lead, mercury, or mercury compounds.
- C. Products that come in contact with stainless steel shall have a leachable chloride content of less than 50 ppm when tested according to ASTM C 871.
- D. Insulation materials for use on austenitic stainless steel shall be qualified as acceptable according to ASTM C 795.
- E. Foam insulation materials shall not use CFC or HCFC blowing agents in the manufacturing process.
- F. Mineral-Fiber Blanket Insulation: Mineral or glass fibers bonded with a thermosetting resin. Comply with ASTM C 553, Type II and ASTM C 1290, Type III with factory-applied FSK jacket or Type III with factory-applied FSP jacket. Factory-applied jacket requirements are specified in "Factory-Applied Jackets" Article.
 - 1. Products: Subject to compliance with requirements, available products that may be incorporated into the Work include, but are not limited to, the following:
 - a. CertainTeed Corp.; SoftTouch Duct Wrap.
 - b. Johns Manville; Microlite.
 - c. Knauf Insulation; Friendly Feel Duct Wrap.
 - d. Manson Insulation Inc.; Alley Wrap.
 - e. Owens Corning; SOFTR All-Service Duct Wrap.

2.02 ADHESIVES

- A. Materials shall be compatible with insulation materials, jackets, and substrates and for bonding insulation to itself and to surfaces to be insulated unless otherwise indicated.
- B. Mineral-Fiber Adhesive: Comply with MIL-A-3316C, Class 2, Grade A.
 - 1. Products: Subject to compliance with requirements, available products that may be incorporated into the Work include, but are not limited to, the following:
 - a. Childers Brand, Specialty Construction Brands, Inc., a business of H. B. Fuller Company; CP-127.Eagle Bridges - Marathon Industries; 225.
 - b. Foster Brand, Specialty Construction Brands, Inc., a business of H.B. Fuller Company; 85-60/85-70.Mon-Eco Industries, Inc.; 22-25.
 - 2. For indoor applications, adhesive shall have a VOC content of 80 g/L or less when calculated according to 40 CFR 59, Subpart D (EPA Method 24).
 - 3. Adhesive shall comply with the testing and product requirements of the California Department of Health Services' "Standard Practice for the Testing of Volatile Organic Emissions from Various Sources Using Small-Scale Environmental

Chambers."

- C. ASJ Adhesive, and FSK Jacket Adhesive: Comply with MIL-A-3316C, Class 2, Grade A for bonding insulation jacket lap seams and joints.
1. Products: Subject to compliance with requirements, available products that may be incorporated into the Work include, but are not limited to, the following:
 - a. Childers Brand, Specialty Construction Brands, Inc., a business of H. B. Fuller Company; CP-82.
 - b. Eagle Bridges - Marathon Industries; 225.
 - c. Foster Brand, Specialty Construction Brands, Inc., a business of H. B. Fuller Company; 85-50. Mon-Eco Industries, Inc.; 22-25.
 2. For indoor applications, adhesive shall have a VOC content of 50 g/L or less when calculated according to 40 CFR 59, Subpart D (EPA Method 24).
 3. Adhesive shall comply with the testing and product requirements of the California Department of Health Services' "Standard Practice for the Testing of Volatile Organic Emissions from Various Sources Using Small-Scale Environmental Chambers."

2.03 MASTICS

- A. Materials shall be compatible with insulation materials, jackets, and substrates; comply with MIL-PRF-19565C, Type II.
1. For indoor applications, use mastics that have a VOC content of 50 g/L or less when calculated according to 40 CFR 59, Subpart D (EPA Method 24).
- B. Vapor-Barrier Mastic: Water based; suitable for indoor use on below ambient services.
1. Products: Subject to compliance with requirements, available products that may be incorporated into the Work include, but are not limited to, the following:
 - a. Foster Brand, Specialty Construction Brands, Inc., a business of H. B. Fuller Company; 30-80/30-90.
 - b. Vimasco Corporation; 749.
 2. Water-Vapor Permeance: ASTM E 96/E 96M, Procedure B, 0.013 perm at 43-mil dry film thickness.
 3. Service Temperature Range: Minus 20 to plus 180 deg F.
 4. Solids Content: ASTM D 1644, 58 percent by volume and 70 percent by weight.
 5. Color: White.
- C. Vapor-Barrier Mastic: Solvent based; suitable for indoor use on below ambient services.
1. Products: Subject to compliance with requirements, available products that may be incorporated into the Work include, but are not limited to, the following:
 - a. Childers Brand, Specialty Construction Brands, Inc., a business of H. B. Fuller Company; CP-30.
 - b. Eagle Bridges - Marathon Industries; 501.
 - c. Foster Brand, Specialty Construction Brands, Inc., a business of H. B. Fuller Company; 30-35.
 - d. Mon-Eco Industries, Inc.; 55-10.
 2. Water-Vapor Permeance: ASTM F 1249, 0.05 perm at 35-mil dry film thickness.
 3. Service Temperature Range: 0 to 180 deg F.
 4. Solids Content: ASTM D 1644, 44 percent by volume and 62 percent by weight.
 5. Color: White.
- D. Vapor-Barrier Mastic: Solvent based; suitable for outdoor use on below ambient services.
1. Products: Subject to compliance with requirements, available products that may be incorporated into the Work include, but are not limited to, the following:
 - a. Childers Brand, Specialty Construction Brands, Inc., a business of H. B. Fuller Company; Encacel.
 - b. Eagle Bridges - Marathon Industries; 570.
 - c. Foster Brand, Specialty Construction Brands, Inc., a business of H. B. Fuller Company; 60-95/60-96.
 2. Water-Vapor Permeance: ASTM F 1249, 0.05 perm at 30-mil dry film thickness.

3. Service Temperature Range: Minus 50 to plus 220 deg F.
 4. Solids Content: ASTM D 1644, 33 percent by volume and 46 percent by weight.
 5. Color: White.
- E. Breather Mastic: Water based; suitable for indoor and outdoor use on above ambient services.
1. Products: Subject to compliance with requirements, available products that may be incorporated into the Work include, but are not limited to, the following:
 - a. Childers Brand, Specialty Construction Brands, Inc., a business of H. B. Fuller Company; CP-10.
 - b. Eagle Bridges - Marathon Industries; 550.
 - c. Foster Brand, Specialty Construction Brands, Inc., a business of H. B. Fuller Company; 46-50.
 - d. Mon-Eco Industries, Inc.; 55-50.
 - e. Vimasco Corporation; WC-1/WC-5.
 2. Water-Vapor Permeance: ASTM F 1249, 1.8 perms at 0.0625-inch dry film thickness.
 3. Service Temperature Range: Minus 20 to plus 180 deg F.
 4. Solids Content: 60 percent by volume and 66 percent by weight.
 5. Color: White.

2.04 LAGGING ADHESIVES

- A. Description: Comply with MIL-A-3316C, Class I, Grade A and shall be compatible with insulation materials, jackets, and substrates.
1. For indoor applications, use lagging adhesives that have a VOC content of 50 g/L or less when calculated according to 40 CFR 59, Subpart D (EPA Method 24).
 2. Products: Subject to compliance with requirements, available products that may be incorporated into the Work include, but are not limited to, the following:
 - a. Childers Brand, Specialty Construction Brands, Inc., a business of H. B. Fuller Company; CP-50 AHV2. Foster Brand, Specialty Construction Brands, Inc., a business of H. B. Fuller Company; 30-36.
 - b. Vimasco Corporation; 713 and 714.
 3. Fire-resistant, water-based lagging adhesive and coating for use indoors to adhere fire-resistant lagging cloths over duct insulation.
 4. Service Temperature Range: 0 to plus 180 deg F.
 5. Color: White.

2.05 SEALANTS

- A. FSK and Metal Jacket Flashing Sealants:
1. Products: Subject to compliance with requirements, available products that may be incorporated into the Work include, but are not limited to, the following:
 - a. Childers Brand, Specialty Construction Brands, Inc., a business of H. B. Fuller Company; CP-76. Eagle Bridges - Marathon Industries; 405.
 - b. Foster Brand, Specialty Construction Brands, Inc., a business of H. B. Fuller Company; 95-44.
 - c. Mon-Eco Industries, Inc.; 44-05.
 2. Materials shall be compatible with insulation materials, jackets, and substrates.
 3. Fire- and water-resistant, flexible, elastomeric sealant.
 4. Service Temperature Range: Minus 40 to plus 250 deg F.
 5. Color: Aluminum.
 6. For indoor applications, sealants shall have a VOC content of 420 g/L or less when calculated according to 40 CFR 59, Subpart D (EPA Method 24).
 7. Sealants shall comply with the testing and product requirements of the California Department of Health Services' "Standard Practice for the Testing of Volatile Organic Emissions from Various Sources Using Small-Scale Environmental Chambers."

2.06 FACTORY-APPLIED JACKETS

- A. Insulation system schedules indicate factory-applied jackets on various applications.

When factory-applied jackets are indicated, comply with the following:

1. FSK Jacket: Aluminum-foil, fiberglass-reinforced scrim with kraft-paper backing; complying with ASTM C 1136, Type II.

2.07 FIELD-APPLIED FABRIC-REINFORCING MESH

- A. Woven Glass-Fiber Fabric: Approximately 6 oz./sq. yd. with a thread count of 5 strands by 5 strands/sq. in. for covering ducts.
 1. Products: Subject to compliance with requirements, available products that may be incorporated into the Work include, but are not limited to, the following:
 - a. Childers Brand, Specialty Construction Brands, Inc., a business of H. B. Fuller Company; Chil-Glas No. 5.
- B. Woven Polyester Fabric: Approximately 1 oz./sq. yd. with a thread count of 10 strands by 10 strands/sq. in., in a Leno weave, for ducts.
 1. Products: Subject to compliance with requirements, available products that may be incorporated into the Work include, but are not limited to, the following:
 - a. Foster Brand, Specialty Construction Brands, Inc., a business of H. B. Fuller Company; Mast-A-Fab.
 - b. Vimasco Corporation; Elastafab 894.

2.08 FIELD-APPLIED CLOTHS

- A. Woven Glass-Fiber Fabric: Comply with MIL-C-20079H, Type I, plain weave, and presized a minimum of 8 oz./sq. yd.
 1. Products: Subject to compliance with requirements, available products that may be incorporated into the Work include, but are not limited to, the following:
 - a. Alpha Associates, Inc.; Alpha-Maritex 84215 and 84217/9485RW, Luben 59.

2.09 TAPES

- A. FSK Tape: Foil-face, vapor-retarder tape matching factory-applied jacket with acrylic adhesive; complying with ASTM C 1136.
 1. Products: Subject to compliance with requirements, available products that may be incorporated into the Work include, but are not limited to, the following:
 - a. ABI, Ideal Tape Division; 491 AWF FSK.
 - b. Avery Dennison Corporation, Specialty Tapes Division; Fasson 0827.
 - c. Compac Corporation; 110 and 111.
 - d. Venture Tape; 1525 CW NT, 1528 CW, and 1528 CW/SQ.
 2. Width: 3 inches.
 3. Thickness: 6.5 mils.
 4. Adhesion: 90 ounces force/inch in width.
 5. Elongation: 2 percent.
 6. Tensile Strength: 40 lbf/inch in width.
 7. FSK Tape Disks and Squares: Precut disks or squares of FSK tape.

2.10 SECUREMENTS

- A. Bands:
 1. Products: Subject to compliance with requirements, available products that may be incorporated into the Work include, but are not limited to, the following:
 - a. ITW Insulation Systems; Gerrard Strapping and Seals.
 - b. RPR Products, Inc.; Insul-Mate Strapping, Seals, and Springs.
 2. Stainless Steel: ASTM A 167 or ASTM A 240/A 240M, Type 304 or Type 316; 0.015 inch thick, 3/4 inch wide with wing seal or closed seal.
 3. Aluminum: ASTM B 209, Alloy 3003, 3005, 3105, or 5005; Temper H-14, 0.020 inch thick, 3/4 inch wide with wing seal or closed seal.
 4. Springs: Twin spring set constructed of stainless steel with ends flat and slotted to accept metal bands. Spring size determined by manufacturer for application.
- B. Insulation Pins and Hangers:
 1. Capacitor-Discharge-Weld Pins: Copper- or zinc-coated steel pin, fully annealed for capacitor-discharge welding, 0.106-inch- or 0.135-inch- diameter shank,

- length to suit depth of insulation indicated.
- a. Products: Subject to compliance with requirements, available products that may be incorporated into the Work include, but are not limited to, the following:
 - 1) AGM Industries, Inc.; CWP-1.
 - 2) GEMCO; CD.
 - 3) Midwest Fasteners, Inc.; CD.
 - 4) Nelson Stud Welding; TPA, TPC, and TPS.
 2. Cupped-Head, Capacitor-Discharge-Weld Pins: Copper- or zinc-coated steel pin, fully annealed for capacitor-discharge welding, 0.106-inch- or 0.135-inch-diameter shank, length to suit depth of insulation indicated with integral 1-1/2-inch galvanized carbon-steel washer.
 - a. Products: Subject to compliance with requirements, available products that may be incorporated into the Work include, but are not limited to, the following:
 - 1) AGM Industries, Inc.; CHP-1.
 - 2) GEMCO; Cupped Head Weld Pin.
 - 3) Midwest Fasteners, Inc.; Cupped Head.
 - 4) Nelson Stud Welding; CHP.
 3. Metal, Adhesively Attached, Perforated-Base Insulation Hangers: Baseplate welded to projecting spindle that is capable of holding insulation, of thickness indicated, securely in position indicated when self-locking washer is in place. Comply with the following requirements:
 - a. Products: Subject to compliance with requirements, available products that may be incorporated into the Work include, but are not limited to, the following:
 - 1) AGM Industries, Inc.; Tactoo Perforated Base Insul-Hangers.
 - 2) GEMCO; Perforated Base.
 - 3) Midwest Fasteners, Inc.; Spindle.
 - b. Baseplate: Perforated, galvanized carbon-steel sheet, 0.030 inch thick by 2 inches square.
 - c. Spindle: Copper- or zinc-coated, low-carbon steel, Aluminum, Stainless steel, fully annealed, 0.106-inch- diameter shank, length to suit depth of insulation indicated.
 - d. Adhesive: Recommended by hanger manufacturer. Product with demonstrated capability to bond insulation hanger securely to substrates indicated without damaging insulation, hangers, and substrates.
 4. Nonmetal, Adhesively Attached, Perforated-Base Insulation Hangers: Baseplate fastened to projecting spindle that is capable of holding insulation, of thickness indicated, securely in position indicated when self-locking washer is in place. Comply with the following requirements:
 - a. Products: Subject to compliance with requirements, available products that may be incorporated into the Work include, but are not limited to, the following:
 - 1) GEMCO; Nylon Hangers.
 - 2) Midwest Fasteners, Inc.; Nylon Insulation Hangers.
 - b. Baseplate: Perforated, nylon sheet, 0.030 inch thick by 1-1/2 inches in diameter.
 - c. Spindle: Nylon, 0.106-inch- diameter shank, length to suit depth of insulation indicated, up to 2-1/2 inches.
 - d. Adhesive: Recommended by hanger manufacturer. Product with demonstrated capability to bond insulation hanger securely to substrates indicated without damaging insulation, hangers, and substrates.
 5. Self-Sticking-Base Insulation Hangers: Baseplate welded to projecting spindle that is capable of holding insulation, of thickness indicated, securely in position indicated when self-locking washer is in place. Comply with the following

requirements:

- a. Products: Subject to compliance with requirements, available products that may be incorporated into the Work include, but are not limited to, the following:
 - 1) AGM Industries, Inc.; Tactoo Self-Adhering Insul-Hangers.
 - 2) GEMCO; Peel & Press.
 - 3) Midwest Fasteners, Inc.; Self Stick.
 - b. Baseplate: Galvanized carbon-steel sheet, 0.030 inch thick by 2 inches square.
 - c. Spindle: Copper- or zinc-coated, low-carbon steel, Aluminum, Stainless steel, fully annealed, 0.106-inch- diameter shank, length to suit depth of insulation indicated.
 - d. Adhesive-backed base with a peel-off protective cover.
6. Insulation-Retaining Washers: Self-locking washers formed from 0.016-inch-thick, galvanized-steel, aluminum, stainless-steel sheet, with beveled edge sized as required to hold insulation securely in place but not less than 1-1/2 inches in diameter.
- a. Products: Subject to compliance with requirements, available products that may be incorporated into the Work include, but are not limited to, the following:
 - 1) AGM Industries, Inc.; RC-150.
 - 2) GEMCO; R-150.
 - 3) Midwest Fasteners, Inc.; WA-150.
 - 4) Nelson Stud Welding; Speed Clips.
 - b. Protect ends with capped self-locking washers incorporating a spring steel insert to ensure permanent retention of cap in exposed locations.
7. Nonmetal Insulation-Retaining Washers: Self-locking washers formed from 0.016-inch- thick nylon sheet, with beveled edge sized as required to hold insulation securely in place but not less than 1-1/2 inches in diameter.
- a. Manufacturers: Subject to compliance with requirements, available manufacturers offering products that may be incorporated into the Work include, but are not limited to, the following:
 - 1) GEMCO.
 - 2) Midwest Fasteners, Inc.
- C. Staples: Outward-clinching insulation staples, nominal 3/4-inch- wide, stainless steel or Monel.
- D. Wire: 0.080-inch nickel-copper alloy, 0.062-inch soft-annealed, stainless steel, or 0.062-inch soft-annealed, galvanized steel.
- 1. Manufacturers: Subject to compliance with requirements, available manufacturers offering products that may be incorporated into the Work include, but are not limited to, the following:
 - a. C & F Wire.

PART 3 EXECUTION

3.01 EXAMINATION

- A. Examine substrates and conditions for compliance with requirements for installation tolerances and other conditions affecting performance of insulation application.
 - 1. Verify that systems to be insulated have been tested and are free of defects.
 - 2. Verify that surfaces to be insulated are clean and dry.
- B. Proceed with installation only after unsatisfactory conditions have been corrected.

3.02 PREPARATION

- A. Surface Preparation: Clean and dry surfaces to receive insulation. Remove materials that will adversely affect insulation application.

3.03 GENERAL INSTALLATION REQUIREMENTS

- A. Install insulation materials, accessories, and finishes with smooth, straight, and even

surfaces; free of voids throughout the length of ducts and fittings.

- B. Install insulation materials, vapor barriers or retarders, jackets, and thicknesses required for each item of duct system as specified in insulation system schedules.
- C. Install accessories compatible with insulation materials and suitable for the service. Install accessories that do not corrode, soften, or otherwise attack insulation or jacket in either wet or dry state.
- D. Install insulation with longitudinal seams at top and bottom of horizontal runs.
- E. Install multiple layers of insulation with longitudinal and end seams staggered.
- F. Keep insulation materials dry during application and finishing.
- G. Install insulation with tight longitudinal seams and end joints. Bond seams and joints with adhesive recommended by insulation material manufacturer.
- H. Install insulation with least number of joints practical.
- I. Where vapor barrier is indicated, seal joints, seams, and penetrations in insulation at hangers, supports, anchors, and other projections with vapor-barrier mastic.
 - 1. Install insulation continuously through hangers and around anchor attachments.
 - 2. For insulation application where vapor barriers are indicated, extend insulation on anchor legs from point of attachment to supported item to point of attachment to structure. Taper and seal ends at attachment to structure with vapor-barrier mastic.
 - 3. Install insert materials and install insulation to tightly join the insert. Seal insulation to insulation inserts with adhesive or sealing compound recommended by insulation material manufacturer.
- J. Apply adhesives, mastics, and sealants at manufacturer's recommended coverage rate and wet and dry film thicknesses.
- K. Install insulation with factory-applied jackets as follows:
 - 1. Draw jacket tight and smooth.
 - 2. Cover circumferential joints with 3-inch- wide strips, of same material as insulation jacket. Secure strips with adhesive and outward clinching staples along both edges of strip, spaced 4 inches o.c.
 - 3. Overlap jacket longitudinal seams at least 1-1/2 inches. Clean and dry surface to receive self-sealing lap. Staple laps with outward clinching staples along edge at 2 inches o.c.
 - a. For below ambient services, apply vapor-barrier mastic over staples.
 - 4. Cover joints and seams with tape, according to insulation material manufacturer's written instructions, to maintain vapor seal.
 - 5. Where vapor barriers are indicated, apply vapor-barrier mastic on seams and joints and at ends adjacent to duct flanges and fittings.
- L. Cut insulation in a manner to avoid compressing insulation more than 75 percent of its nominal thickness.
- M. Finish installation with systems at operating conditions. Repair joint separations and cracking due to thermal movement.
- N. Repair damaged insulation facings by applying same facing material over damaged areas. Extend patches at least 4 inches beyond damaged areas. Adhere, staple, and seal patches similar to butt joints.

3.04 PENETRATIONS

- A. Insulation Installation at Interior Wall and Partition Penetrations (That Are Not Fire Rated): Install insulation continuously through walls and partitions.
- B. Insulation Installation at Fire-Rated Wall and Partition Penetrations: Terminate insulation at fire damper sleeves for fire-rated wall and partition penetrations. Externally insulate damper sleeves to match adjacent insulation and overlap duct insulation at least 2 inches.

1. Comply with requirements in Section 078413 "Penetration Firestopping".

3.05 INSTALLATION OF MINERAL-FIBER INSULATION

- A. Blanket Insulation Installation on Ducts and Plenums: Secure with adhesive and insulation pins.
 1. Apply adhesives according to manufacturer's recommended coverage rates per unit area, for 100 percent coverage of duct and plenum surfaces.
 2. Apply adhesive to entire circumference of ducts and to all surfaces of fittings and transitions.
 3. Install either capacitor-discharge-weld pins and speed washers or cupped-head, capacitor-discharge-weld pins on sides and bottom of horizontal ducts and sides of vertical ducts as follows:
 - a. On duct sides with dimensions 18 inches and smaller, place pins along longitudinal centerline of duct. Space 3 inches maximum from insulation end joints, and 16 inches o.c.
 - b. On duct sides with dimensions larger than 18 inches, place pins 16 inches o.c. each way, and 3 inches maximum from insulation joints. Install additional pins to hold insulation tightly against surface at cross bracing.
 - c. Pins may be omitted from top surface of horizontal, rectangular ducts and plenums.
 - d. Do not over compress insulation during installation.
 - e. Impale insulation over pins and attach speed washers.
 - f. Cut excess portion of pins extending beyond speed washers or bend parallel with insulation surface. Cover exposed pins and washers with tape matching insulation facing.
 4. For ducts and plenums with surface temperatures below ambient, install a continuous unbroken vapor barrier. Create a facing lap for longitudinal seams and end joints with insulation by removing 2 inches from one edge and one end of insulation segment. Secure laps to adjacent insulation section with 1/2-inch outward-clinching staples, 1 inch o.c. Install vapor barrier consisting of factory- or field-applied jacket, adhesive, vapor-barrier mastic, and sealant at joints, seams, and protrusions.
 - a. Repair punctures, tears, and penetrations with tape or mastic to maintain vapor-barrier seal.
 - b. Install vapor stops for ductwork and plenums operating below 50 deg F at 18-foot intervals. Vapor stops shall consist of vapor-barrier mastic applied in a Z-shaped pattern over insulation face, along butt end of insulation, and over the surface. Cover insulation face and surface to be insulated a width equal to two times the insulation thickness, but not less than 3 inches.
 5. Overlap unfaced blankets a minimum of 2 inches on longitudinal seams and end joints. At end joints, secure with steel bands spaced a maximum of 18 inches o.c.
 6. Install insulation on rectangular duct elbows and transitions with a full insulation section for each surface. Install insulation on round and flat-oval duct elbows with individually mitered gores cut to fit the elbow.
 7. Insulate duct stiffeners, hangers, and flanges that protrude beyond insulation surface with 6-inch- wide strips of same material used to insulate duct. Secure on alternating sides of stiffener, hanger, and flange with pins spaced 6 inches o.c.

3.06 FINISHES

- A. Insulation with ASJ, Glass-Cloth, or Other Paintable Jacket Material: Paint jacket with paint system identified below and as specified in Section 099113 "Exterior Painting" and Section 099123 "Interior Painting."
 1. Flat Acrylic Finish: Two finish coats over a primer that is compatible with jacket material and finish coat paint. Add fungicidal agent to render fabric mildew proof.

- a. Finish Coat Material: Interior, flat, latex-emulsion size.
- B. Color: Final color as selected by Architect. Vary first and second coats to allow visual inspection of the completed Work.
- C. Do not field paint aluminum or stainless-steel jackets.

3.07 FIELD QUALITY CONTROL

- A. Testing Agency: Engage a qualified testing agency to perform tests and inspections.
- B. Perform tests and inspections.
- C. Tests and Inspections:
 - 1. Inspect ductwork, randomly selected by Architect, by removing field-applied jacket and insulation in layers in reverse order of their installation. Extent of inspection shall be limited to one location(s) for each duct system defined in the "Duct Insulation Schedule, General" Article.
- D. All insulation applications will be considered defective Work if sample inspection reveals noncompliance with requirements.

3.08 DUCT INSULATION SCHEDULE, GENERAL

- A. Plenums and Ducts Requiring Insulation:
 - 1. All supply, return, and outdoor air.
 - 2. Where energy recovery wheel is present, environmental air exhaust to the wheel.
 - 3. Exhaust between isolation damper and penetration of building exterior.
- B. Items Not Insulated:
 - 1. Fibrous-glass ducts.
 - 2. Metal ducts with duct liner of sufficient thickness to comply with energy code and ASHRAE/IESNA 90.1.
 - 3. Factory-insulated flexible ducts.
 - 4. Factory-insulated plenums and casings.
 - 5. Flexible connectors.
 - 6. Vibration-control devices.
 - 7. Factory-insulated access panels and doors.
 - 8. Environmental air exhaust where energy recovery wheel is not present
 - 9. Where energy recovery wheel is present, environmental air exhaust after the wheel.

3.09 INDOOR DUCT AND PLENUM INSULATION SCHEDULE

- A. Concealed supply, return, and outdoor-air duct and plenum insulation shall be the following:
 - 1. Mineral-Fiber Blanket: 2.2 inches thick and 0.75-lb/cu. ft. nominal density.

END OF SECTION

SECTION 23 07 19
HVAC PIPING INSULATION

PART 1 GENERAL**1.01 RELATED DOCUMENTS**

- A. Drawings and general provisions of the Contract, including General and Supplementary Conditions and Division 01 Specification Sections, apply to this Section.

1.02 SUMMARY

- A. Section includes insulating the following HVAC piping systems:
 - 1. Condensate drain piping, indoors and outdoors.
 - 2. Refrigerant suction and hot-gas piping, indoors and outdoors.
- B. Related Sections:
 - 1. Section 230713 "Duct Insulation."

1.03 ACTION SUBMITTALS

- A. Product Data: For each type of product indicated. Include thermal conductivity, water-vapor permeance thickness, and jackets (both factory and field applied if any).
- B. Shop Drawings: Include plans, elevations, sections, details, and attachments to other work.
 - 1. Detail application of protective shields, saddles, and inserts at hangers for each type of insulation and hanger.
 - 2. Detail attachment and covering of heat tracing inside insulation.
 - 3. Detail insulation application at pipe expansion joints for each type of insulation.
 - 4. Detail insulation application at elbows, fittings, flanges, valves, and specialties for each type of insulation.
 - 5. Detail removable insulation at piping specialties.
 - 6. Detail application of field-applied jackets.
 - 7. Detail application at linkages of control devices.

1.04 INFORMATIONAL SUBMITTALS

- A. Qualification Data: For qualified Installer.
- B. Material Test Reports: From a qualified testing agency acceptable to authorities having jurisdiction indicating, interpreting, and certifying test results for compliance of insulation materials, sealers, attachments, cements, and jackets, with requirements indicated. Include dates of tests and test methods employed.
- C. Field quality-control reports.

1.05 QUALITY ASSURANCE

- A. Installer Qualifications: Skilled mechanics who have successfully completed an apprenticeship program or another craft training program certified by the Department of Labor, Bureau of Apprenticeship and Training.
- B. Surface-Burning Characteristics: For insulation and related materials, as determined by testing identical products according to ASTM E 84, by a testing and inspecting agency acceptable to authorities having jurisdiction. Factory label insulation and jacket materials and adhesive, mastic, tapes, and cement material containers, with appropriate markings of applicable testing agency.
 - 1. Insulation Installed Indoors: Flame-spread index of 25 or less, and smoke-developed index of 50 or less.
 - 2. Insulation Installed Outdoors: Flame-spread index of 75 or less, and smoke-developed index of 150 or less.

1.06 DELIVERY, STORAGE, AND HANDLING

- A. Packaging: Insulation material containers shall be marked by manufacturer with appropriate ASTM standard designation, type and grade, and maximum use temperature.

1.07 COORDINATION

- A. Coordinate sizes and locations of supports, hangers, and insulation shields specified in Section 230529 "Hangers and Supports for HVAC Piping and Equipment."
- B. Coordinate clearance requirements with piping Installer for piping insulation application. Before preparing piping Shop Drawings, establish and maintain clearance requirements for installation of insulation and field-applied jackets and finishes and for space required for maintenance.
- C. Coordinate installation and testing of heat tracing.

1.08 SCHEDULING

- A. Schedule insulation application after pressure testing systems and, where required, after installing and testing heat tracing. Insulation application may begin on segments that have satisfactory test results.
- B. Complete installation and concealment of plastic materials as rapidly as possible in each area of construction.

PART 2 PRODUCTS

2.01 INSULATION MATERIALS

- A. Comply with requirements in "Piping Insulation Schedule, General," "Indoor Piping Insulation Schedule," "Outdoor, Aboveground Piping Insulation Schedule," and "Outdoor, Underground Piping Insulation Schedule" articles for where insulating materials shall be applied.
- B. Products shall not contain asbestos, lead, mercury, or mercury compounds.
- C. Products that come in contact with stainless steel shall have a leachable chloride content of less than 50 ppm when tested according to ASTM C 871.
- D. Insulation materials for use on austenitic stainless steel shall be qualified as acceptable according to ASTM C 795.
- E. Foam insulation materials shall not use CFC or HCFC blowing agents in the manufacturing process.
- F. Flexible Elastomeric Insulation: Closed-cell, sponge- or expanded-rubber materials. Comply with ASTM C 534, Type I for tubular materials.
 - 1. Products: Subject to compliance with requirements, available products that may be incorporated into the Work include, but are not limited to, the following:
 - a. Aeroflex USA, Inc.; Aerocel.
 - b. Armacell LLC; AP Armaflex.
 - c. K-Flex USA; Insul-Lock, Insul-Tube, and K-FLEX LS.

2.02 ADHESIVES

- A. Materials shall be compatible with insulation materials, jackets, and substrates and for bonding insulation to itself and to surfaces to be insulated unless otherwise indicated.
- B. Flexible Elastomeric Adhesive: Comply with MIL-A-24179A, Type II, Class I.
 - 1. Products: Subject to compliance with requirements, available products that may be incorporated into the Work include, but are not limited to, the following:
 - a. Aeroflex USA, Inc.; Aero seal.
 - b. Armacell LLC; Armaflex 520 Adhesive.
 - c. Foster Brand, Specialty Construction Brands, Inc., a business of H. B. Fuller Company; 85-75.
 - d. K-Flex USA; R-373 Contact Adhesive.
 - 2. For indoor applications, adhesive shall have a VOC content of 50 g/L or less when calculated according to 40 CFR 59, Subpart D (EPA Method 24).
 - 3. Adhesive shall comply with the testing and product requirements of the California Department of Health Services' "Standard Practice for the Testing of Volatile Organic Emissions from Various Sources Using Small-Scale Environmental Chambers."

2.03 MASTICS

- A. Materials shall be compatible with insulation materials, jackets, and substrates; comply with MIL-PRF-19565C, Type II.
 - 1. For indoor applications, use mastics that have a VOC content of 50 g/L or less when calculated according to 40 CFR 59, Subpart D (EPA Method 24).
- B. Vapor-Barrier Mastic: Water based; suitable for indoor use on below-ambient services.
 - 1. Products: Subject to compliance with requirements, available products that may be incorporated into the Work include, but are not limited to, the following:
 - a. Foster Brand, Specialty Construction Brands, Inc., a business of H. B. Fuller Company; 30-80/30-90.
 - b. Vimasco Corporation; 749.
 - 2. Water-Vapor Permeance: ASTM E 96/E 96M, Procedure B, 0.013 perm at 43-mil dry film thickness.
 - 3. Service Temperature Range: Minus 20 to plus 180 deg F.
 - 4. Solids Content: ASTM D 1644, 58 percent by volume and 70 percent by weight.
 - 5. Color: White.
- C. Vapor-Barrier Mastic: Solvent based; suitable for indoor use on below-ambient services.
 - 1. Products: Subject to compliance with requirements, available products that may be incorporated into the Work include, but are not limited to, the following:
 - a. Childers Brand, Specialty Construction Brands, Inc., a business of H. B. Fuller Company; CP-30.
 - b. Eagle Bridges - Marathon Industries; 501.
 - c. Foster Brand, Specialty Construction Brands, Inc., a business of H. B. Fuller Company; 30-35.
 - d. Mon-Eco Industries, Inc.; 55-10.
 - 2. Water-Vapor Permeance: ASTM F 1249, 0.05 perm at 35-mil dry film thickness.
 - 3. Service Temperature Range: 0 to 180 deg F.
 - 4. Solids Content: ASTM D 1644, 44 percent by volume and 62 percent by weight.
 - 5. Color: White.
- D. Vapor-Barrier Mastic: Solvent based; suitable for outdoor use on below-ambient services.
 - 1. Products: Subject to compliance with requirements, available products that may be incorporated into the Work include, but are not limited to, the following:
 - a. Childers Brand, Specialty Construction Brands, Inc., a business of H. B. Fuller Company; Encacel.
 - b. Eagle Bridges - Marathon Industries; 570.
 - c. Foster Brand, Specialty Construction Brands, Inc., a business of H. B. Fuller Company; 60-95/60-96.
 - 2. Water-Vapor Permeance: ASTM F 1249, 0.05 perm at 30-mil dry film thickness.
 - 3. Service Temperature Range: Minus 50 to plus 220 deg F.
 - 4. Solids Content: ASTM D 1644, 33 percent by volume and 46 percent by weight.
 - 5. Color: White.

2.04 SEALANTS

- A. Joint Sealants:
 - 1. Materials shall be compatible with insulation materials, jackets, and substrates.
 - 2. Permanently flexible, elastomeric sealant.
 - 3. Service Temperature Range: Minus 100 to plus 300 deg F.
 - 4. For indoor applications, sealants shall have a VOC content of 420 g/L or less when calculated according to 40 CFR 59, Subpart D (EPA Method 24).
- B. FSK and Metal Jacket Flashing Sealants:
 - 1. Products: Subject to compliance with requirements, available products that may be incorporated into the Work include, but are not limited to, the following:
 - a. Childers Brand, Specialty Construction Brands, Inc., a business of H. B. Fuller Company; CP-76.
 - b. Eagle Bridges - Marathon Industries; 405.
 - c. Foster Brand, Specialty Construction Brands, Inc., a business of H. B.

- Fuller Company; 95-44.
- d. Mon-Eco Industries, Inc.; 44-05.
- 2. Materials shall be compatible with insulation materials, jackets, and substrates.
- 3. Fire- and water-resistant, flexible, elastomeric sealant.
- 4. Service Temperature Range: Minus 40 to plus 250 deg F.
- 5. Color: Aluminum.
- 6. For indoor applications, sealants shall have a VOC content of 420 g/L or less when calculated according to 40 CFR 59, Subpart D (EPA Method 24).
- 7. Sealants shall comply with the testing and product requirements of the California Department of Health Services' "Standard Practice for the Testing of Volatile Organic Emissions from Various Sources Using Small-Scale Environmental Chambers."

2.05 SECUREMENTS

- A. Bands:
 - 1. Products: Subject to compliance with requirements, available products that may be incorporated into the Work include, but are not limited to, the following:
 - a. ITW Insulation Systems; Gerrard Strapping and Seals.
 - b. RPR Products, Inc.; Insul-Mate Strapping, Seals, and Springs.
 - 2. Stainless Steel: ASTM A 167 or ASTM A 240/A 240M, Type 304 or Type 316; 0.015 inch thick, 1/2 inch wide with wing seal or closed seal.
 - 3. Aluminum: ASTM B 209, Alloy 3003, 3005, 3105, or 5005; Temper H-14, 0.020 inch thick, 1/2 inch wide with wing seal or closed seal.
 - 4. Springs: Twin spring set constructed of stainless steel with ends flat and slotted to accept metal bands. Spring size determined by manufacturer for application.
- B. Staples: Outward-clinching insulation staples, nominal 3/4-inch- wide, stainless steel or Monel.
- C. Wire: 0.080-inch nickel-copper alloy, 0.062-inch soft-annealed, stainless steel, or 0.062-inch soft-annealed, galvanized steel].
 - 1. Manufacturers: Subject to compliance with requirements, available manufacturers offering products that may be incorporated into the Work include, but are not limited to, the following:
 - a. C & F Wire.

2.06 FACTORY-APPLIED JACKETS

- A. Insulation system schedules indicate factory-applied jackets on various applications. When factory-applied jackets are indicated, comply with the following:
 - 1. ASJ: White, kraft-paper, fiberglass-reinforced scrim with aluminum-foil backing; complying with ASTM C 1136, Type I.
 - 2. ASJ-SSL: ASJ with self-sealing, pressure-sensitive, acrylic-based adhesive covered by a removable protective strip; complying with ASTM C 1136, Type I.

2.07 FIELD-APPLIED JACKETS

- A. Field-applied jackets shall comply with ASTM C 921, Type I, unless otherwise indicated.
- B. PVC Jacket: High-impact-resistant, UV-resistant PVC complying with ASTM D 1784, Class 16354-C; thickness as scheduled; roll stock ready for shop or field cutting and forming. Thickness is indicated in field-applied jacket schedules.
 - 1. Adhesive: As recommended by jacket material manufacturer.
 - 2. Factory-fabricated fitting covers to match jacket if available; otherwise, field fabricated.
 - a. Shapes: 45- and 90-degree, short- and long-radius elbows, tees, valves, flanges, unions, reducers, end caps, soil-pipe hubs, traps, mechanical joints, and P-trap and supply covers for lavatories.
- C. Metal Jacket:
 - 1. Aluminum Jacket: Comply with ASTM B 209, Alloy 3003, 3005, 3105, or 5005, Temper H-14.
 - a. Sheet and roll stock ready for shop or field sizing.

- b. Finish and thickness are indicated in field-applied jacket schedules.
- c. Moisture Barrier for Indoor Applications: **1-mil-** thick, heat-bonded polyethylene and kraft paper.
- d. Moisture Barrier for Outdoor Applications: **3-mil-** thick, heat-bonded polyethylene and kraft paper.
- e. Factory-Fabricated Fitting Covers:
 - 1) Same material, finish, and thickness as jacket.
 - 2) Preformed 2-piece or gore, 45- and 90-degree, short- and long-radius elbows.
 - 3) Tee covers.
 - 4) Flange and union covers.
 - 5) End caps.
 - 6) Beveled collars.
 - 7) Valve covers.
 - 8) Field fabricate fitting covers only if factory-fabricated fitting covers are not available.

PART 3 EXECUTION

3.01 EXAMINATION

- A. Examine substrates and conditions for compliance with requirements for installation tolerances and other conditions affecting performance of insulation application.
 - 1. Verify that systems to be insulated have been tested and are free of defects.
 - 2. Verify that surfaces to be insulated are clean and dry.
 - 3. Proceed with installation only after unsatisfactory conditions have been corrected.

3.02 PREPARATION

- A. Surface Preparation: Clean and dry surfaces to receive insulation. Remove materials that will adversely affect insulation application.
- B. Surface Preparation: Clean and prepare surfaces to be insulated. Before insulating, apply a corrosion coating to insulated surfaces as follows:
 - 1. Stainless Steel: Coat 300 series stainless steel with an epoxy primer 5 mils thick and an epoxy finish 5 mils thick if operating in a temperature range between 140 and 300 deg F. Consult coating manufacturer for appropriate coating materials and application methods for operating temperature range.
 - 2. Carbon Steel: Coat carbon steel operating at a service temperature between 32 and 300 deg F with an epoxy coating. Consult coating manufacturer for appropriate coating materials and application methods for operating temperature range.
- C. Coordinate insulation installation with the trade installing heat tracing. Comply with requirements for heat tracing that apply to insulation.
- D. Mix insulating cements with clean potable water; if insulating cements are to be in contact with stainless-steel surfaces, use demineralized water.

3.03 GENERAL INSTALLATION REQUIREMENTS

- A. Install insulation materials, accessories, and finishes with smooth, straight, and even surfaces; free of voids throughout the length of piping including fittings, valves, and specialties.
- B. Install insulation materials, forms, vapor barriers or retarders, jackets, and thicknesses required for each item of pipe system as specified in insulation system schedules.
- C. Install accessories compatible with insulation materials and suitable for the service. Install accessories that do not corrode, soften, or otherwise attack insulation or jacket in either wet or dry state.
- D. Install insulation with longitudinal seams at top and bottom of horizontal runs.
- E. Install multiple layers of insulation with longitudinal and end seams staggered.

- F. Do not weld brackets, clips, or other attachment devices to piping, fittings, and specialties.
- G. Keep insulation materials dry during application and finishing.
- H. Install insulation with tight longitudinal seams and end joints. Bond seams and joints with adhesive recommended by insulation material manufacturer.
- I. Install insulation with least number of joints practical.
- J. Where vapor barrier is indicated, seal joints, seams, and penetrations in insulation at hangers, supports, anchors, and other projections with vapor-barrier mastic.
 - 1. Install insulation continuously through hangers and around anchor attachments.
 - 2. For insulation application where vapor barriers are indicated, extend insulation on anchor legs from point of attachment to supported item to point of attachment to structure. Taper and seal ends at attachment to structure with vapor-barrier mastic.
 - 3. Install insert materials and install insulation to tightly join the insert. Seal insulation to insulation inserts with adhesive or sealing compound recommended by insulation material manufacturer.
 - 4. Cover inserts with jacket material matching adjacent pipe insulation. Install shields over jacket, arranged to protect jacket from tear or puncture by hanger, support, and shield.
- K. Apply adhesives, mastics, and sealants at manufacturer's recommended coverage rate and wet and dry film thicknesses.
- L. Install insulation with factory-applied jackets as follows:
 - 1. Draw jacket tight and smooth.
 - 2. Cover circumferential joints with 3-inch- wide strips, of same material as insulation jacket. Secure strips with adhesive and outward clinching staples along both edges of strip, spaced 4 inches o.c.
 - 3. Overlap jacket longitudinal seams at least 1-1/2 inches. Install insulation with longitudinal seams at bottom of pipe. Clean and dry surface to receive self-sealing lap. Staple laps with outward clinching staples along edge at 2 inches o.c.
 - a. For below-ambient services, apply vapor-barrier mastic over staples.
 - 4. Cover joints and seams with tape, according to insulation material manufacturer's written instructions, to maintain vapor seal.
 - 5. Where vapor barriers are indicated, apply vapor-barrier mastic on seams and joints and at ends adjacent to pipe flanges and fittings.
- M. Cut insulation in a manner to avoid compressing insulation more than 75 percent of its nominal thickness.
- N. Finish installation with systems at operating conditions. Repair joint separations and cracking due to thermal movement.
- O. Repair damaged insulation facings by applying same facing material over damaged areas. Extend patches at least 4 inches beyond damaged areas. Adhere, staple, and seal patches similar to butt joints.
- P. For above-ambient services, do not install insulation to the following:
 - 1. Vibration-control devices.
 - 2. Testing agency labels and stamps.
 - 3. Nameplates and data plates.
 - 4. Manholes.
 - 5. Handholes.
 - 6. Cleanouts.

3.04 PENETRATIONS

- A. Insulation Installation at Roof Penetrations: Install insulation continuously through roof penetrations.
 - 1. Seal penetrations with flashing sealant.

2. For applications requiring only indoor insulation, terminate insulation above roof surface and seal with joint sealant. For applications requiring indoor and outdoor insulation, install insulation for outdoor applications tightly joined to indoor insulation ends. Seal joint with joint sealant.
 3. Extend jacket of outdoor insulation outside roof flashing at least 2 inches below top of roof flashing.
 4. Seal jacket to roof flashing with flashing sealant.
- B. Insulation Installation at Underground Exterior Wall Penetrations: Terminate insulation flush with sleeve seal. Seal terminations with flashing sealant.
- C. Insulation Installation at Aboveground Exterior Wall Penetrations: Install insulation continuously through wall penetrations.
1. Seal penetrations with flashing sealant.
 2. For applications requiring only indoor insulation, terminate insulation inside wall surface and seal with joint sealant. For applications requiring indoor and outdoor insulation, install insulation for outdoor applications tightly joined to indoor insulation ends. Seal joint with joint sealant.
 3. Extend jacket of outdoor insulation outside wall flashing and overlap wall flashing at least 2 inches.
 4. Seal jacket to wall flashing with flashing sealant.
- D. Insulation Installation at Interior Wall and Partition Penetrations (That Are Not Fire Rated): Install insulation continuously through walls and partitions.
- E. Insulation Installation at Fire-Rated Wall and Partition Penetrations: Install insulation continuously through penetrations of fire-rated walls and partitions.
1. Comply with requirements in Section 078413 "Penetration Firestopping" for firestopping and fire-resistive joint sealers.

3.05 GENERAL PIPE INSULATION INSTALLATION

- A. Requirements in this article generally apply to all insulation materials except where more specific requirements are specified in various pipe insulation material installation articles.
- B. Insulation Installation on Fittings, Valves, Strainers, Flanges, and Unions:
1. Install insulation over fittings, valves, strainers, flanges, unions, and other specialties with continuous thermal and vapor-retarder integrity unless otherwise indicated.
 2. Insulate pipe elbows using preformed fitting insulation or mitered fittings made from same material and density as adjacent pipe insulation. Each piece shall be butted tightly against adjoining piece and bonded with adhesive. Fill joints, seams, voids, and irregular surfaces with insulating cement finished to a smooth, hard, and uniform contour that is uniform with adjoining pipe insulation.
 3. Insulate tee fittings with preformed fitting insulation or sectional pipe insulation of same material and thickness as used for adjacent pipe. Cut sectional pipe insulation to fit. Butt each section closely to the next and hold in place with tie wire. Bond pieces with adhesive.
 4. Insulate valves using preformed fitting insulation or sectional pipe insulation of same material, density, and thickness as used for adjacent pipe. Overlap adjoining pipe insulation by not less than two times the thickness of pipe insulation, or one pipe diameter, whichever is thicker. For valves, insulate up to and including the bonnets, valve stuffing-box studs, bolts, and nuts. Fill joints, seams, and irregular surfaces with insulating cement.
 5. Insulate strainers using preformed fitting insulation or sectional pipe insulation of same material, density, and thickness as used for adjacent pipe. Overlap adjoining pipe insulation by not less than two times the thickness of pipe insulation, or one pipe diameter, whichever is thicker. Fill joints, seams, and irregular surfaces with insulating cement. Insulate strainers so strainer basket flange or plug can be easily removed and replaced without damaging the insulation and jacket. Provide a removable reusable insulation cover. For below-ambient services, provide a design that maintains vapor barrier.

6. Insulate flanges and unions using a section of oversized preformed pipe insulation. Overlap adjoining pipe insulation by not less than two times the thickness of pipe insulation, or one pipe diameter, whichever is thicker.
 7. Cover segmented insulated surfaces with a layer of finishing cement and coat with a mastic. Install vapor-barrier mastic for below-ambient services and a breather mastic for above-ambient services. Reinforce the mastic with fabric-reinforcing mesh. Trowel the mastic to a smooth and well-shaped contour.
 8. For services not specified to receive a field-applied jacket except for flexible elastomeric and polyolefin, install fitted PVC cover over elbows, tees, strainers, valves, flanges, and unions. Terminate ends with PVC end caps. Tape PVC covers to adjoining insulation facing using PVC tape.
 9. Stencil or label the outside insulation jacket of each union with the word "union." Match size and color of pipe labels.
- C. Insulate instrument connections for thermometers, pressure gages, pressure temperature taps, test connections, flow meters, sensors, switches, and transmitters on insulated pipes. Shape insulation at these connections by tapering it to and around the connection with insulating cement and finish with finishing cement, mastic, and flashing sealant.
- D. Install removable insulation covers at locations indicated. Installation shall conform to the following:
1. Make removable flange and union insulation from sectional pipe insulation of same thickness as that on adjoining pipe. Install same insulation jacket as adjoining pipe insulation.
 2. When flange and union covers are made from sectional pipe insulation, extend insulation from flanges or union long at least two times the insulation thickness over adjacent pipe insulation on each side of flange or union. Secure flange cover in place with stainless-steel or aluminum bands. Select band material compatible with insulation and jacket.
 3. Construct removable valve insulation covers in same manner as for flanges, except divide the two-part section on the vertical center line of valve body.
 4. When covers are made from block insulation, make two halves, each consisting of mitered blocks wired to stainless-steel fabric. Secure this wire frame, with its attached insulation, to flanges with tie wire. Extend insulation at least 2 inches over adjacent pipe insulation on each side of valve. Fill space between flange or union cover and pipe insulation with insulating cement. Finish cover assembly with insulating cement applied in two coats. After first coat is dry, apply and trowel second coat to a smooth finish.
 5. Unless a PVC jacket is indicated in field-applied jacket schedules, finish exposed surfaces with a metal jacket.

3.06 INSTALLATION OF FLEXIBLE ELASTOMERIC INSULATION

- A. Seal longitudinal seams and end joints with manufacturer's recommended adhesive to eliminate openings in insulation that allow passage of air to surface being insulated.
- B. Insulation Installation on Pipe Flanges:
1. Install pipe insulation to outer diameter of pipe flange.
 2. Make width of insulation section same as overall width of flange and bolts, plus twice the thickness of pipe insulation.
 3. Fill voids between inner circumference of flange insulation and outer circumference of adjacent straight pipe segments with cut sections of sheet insulation of same thickness as pipe insulation.
 4. Secure insulation to flanges and seal seams with manufacturer's recommended adhesive to eliminate openings in insulation that allow passage of air to surface being insulated.
- C. Insulation Installation on Pipe Fittings and Elbows:
1. Install mitered sections of pipe insulation.
 2. Secure insulation materials and seal seams with manufacturer's recommended adhesive to eliminate openings in insulation that allow passage of air to surface

being insulated.

- D. Insulation Installation on Valves and Pipe Specialties:
1. Install preformed valve covers manufactured of same material as pipe insulation when available.
 2. When preformed valve covers are not available, install cut sections of pipe and sheet insulation to valve body. Arrange insulation to permit access to packing and to allow valve operation without disturbing insulation.
 3. Install insulation to flanges as specified for flange insulation application.
 4. Secure insulation to valves and specialties and seal seams with manufacturer's recommended adhesive to eliminate openings in insulation that allow passage of air to surface being insulated.

3.07 FINISHES

- A. Pipe Insulation with ASJ, Glass-Cloth, or Other Paintable Jacket Material: Paint jacket with paint system identified below and as specified in Section 099113 "Exterior Painting" and Section 099123 "Interior Painting."
1. Flat Acrylic Finish: Two finish coats over a primer that is compatible with jacket material and finish coat paint. Add fungicidal agent to render fabric mildew proof.
 - a. Finish Coat Material: Interior, flat, latex-emulsion size.
- B. Flexible Elastomeric Thermal Insulation: After adhesive has fully cured, apply two coats of insulation manufacturer's recommended protective coating.
- C. Color: Final color as selected by Architect. Vary first and second coats to allow visual inspection of the completed Work.
- D. Do not field paint aluminum or stainless-steel jackets.

3.08 FIELD QUALITY CONTROL

- A. Testing Agency: Engage a qualified testing agency to perform tests and inspections.
- B. Perform tests and inspections.
- C. Tests and Inspections:
1. Inspect pipe, fittings, strainers, and valves, randomly selected by Architect, by removing field-applied jacket and insulation in layers in reverse order of their installation. Extent of inspection shall be limited to three locations of straight pipe, three locations of threaded fittings, three locations of welded fittings, two locations of threaded strainers, two locations of welded strainers, three locations of threaded valves, and three locations of flanged valves for each pipe service defined in the "Piping Insulation Schedule, General" Article.
- D. All insulation applications will be considered defective Work if sample inspection reveals noncompliance with requirements.

3.09 PIPING INSULATION SCHEDULE, GENERAL

- A. Acceptable preformed pipe and tubular insulation materials and thicknesses are identified for each piping system and pipe size range. If more than one material is listed for a piping system, selection from materials listed is Contractor's option.
- B. Items Not Insulated: Unless otherwise indicated, do not install insulation on the following:
1. Drainage piping located in crawl spaces.
 2. Underground piping.
 3. Chrome-plated pipes and fittings unless there is a potential for personnel injury.

3.10 INDOOR PIPING INSULATION SCHEDULE

- A. Condensate and Equipment Drain Water:
1. All Pipe Sizes: Insulation shall be one of the following:
 - a. Flexible Elastomeric: 1 inch thick.
- B. Refrigerant Suction and Hot-Gas Piping/tubing:
1. All Pipe Sizes: Insulation shall be one of the following:
 - a. Flexible Elastomeric: 1 inch thick.

3.11 OUTDOOR, ABOVEGROUND PIPING INSULATION SCHEDULE

- A. Refrigerant Suction and Hot-Gas Piping/tubing:
 - 1. All Pipe Sizes: Insulation shall be one of the following:
 - a. Flexible Elastomeric: 2 inches thick.

3.12 OUTDOOR, EXPOSED, FIELD-APPLIED JACKET SCHEDULE

- A. Install jacket over insulation material. For insulation with factory-applied jacket, install the field-applied jacket over the factory-applied jacket.
- B. If more than one material is listed, selection from materials listed is Contractor's option.
- C. Aluminum, with Z-Shaped Locking Seam: 0.040 inch thick.

END OF SECTION

SECTION 23 23 00
REFRIGERANT PIPING

PART 1 GENERAL**1.01 RELATED DOCUMENTS**

- A. Drawings and general provisions of the Contract, including General and Supplementary Conditions and Division 01 Specification Sections, apply to this Section.

1.02 SUMMARY

- A. This Section includes refrigerant piping used for air-conditioning applications.

1.03 PERFORMANCE REQUIREMENTS

- A. Line Test Pressure for Refrigerant R-410A:
1. Suction Lines for Air-Conditioning Applications: 300 psig.
 2. Suction Lines for Heat-Pump Applications: 535 psig.
 3. Hot-Gas and Liquid Lines: 535 psig.

1.04 ACTION SUBMITTALS

- A. Product Data: For each type of valve and refrigerant piping specialty indicated. Include pressure drop, based on manufacturer's test data, for the following:
1. Thermostatic expansion valves.
 2. Solenoid valves.
 3. Hot-gas bypass valves.
 4. Filter dryers.
 5. Strainers.
 6. Pressure-regulating valves.
- B. Shop Drawings: Show layout of refrigerant piping and specialties, including pipe, tube, and fitting sizes, flow capacities, valve arrangements and locations, slopes of horizontal runs, oil traps, double risers, wall and floor penetrations, and equipment connection details. Show interface and spatial relationships between piping and equipment.
1. Shop Drawing Scale: 1/4 inch equals 1 foot.
 2. Refrigerant piping indicated on Drawings is schematic only. Size piping and design actual piping layout, including oil traps, double risers, specialties, and pipe and tube sizes to accommodate, as a minimum, equipment provided, elevation difference between compressor and evaporator, and length of piping to ensure proper operation and compliance with warranties of connected equipment.

1.05 INFORMATIONAL SUBMITTALS

- A. Welding certificates.
- B. Field quality-control test reports.

1.06 CLOSEOUT SUBMITTALS

- A. Operation and Maintenance Data: For refrigerant valves and piping specialties to include in maintenance manuals.

1.07 QUALITY ASSURANCE

- A. Welding: Qualify procedures and personnel according to ASME Boiler and Pressure Vessel Code: Section IX, "Welding and Brazing Qualifications."
- B. Comply with ASHRAE 15, "Safety Code for Refrigeration Systems."
- C. Comply with ASME B31.5, "Refrigeration Piping and Heat Transfer Components."

1.08 PRODUCT STORAGE AND HANDLING

- A. Store piping in a clean and protected area with end caps in place to ensure that piping interior and exterior are clean when installed.

1.09 COORDINATION

- A. Coordinate size and location of roof curbs, equipment supports, and roof penetrations.

These items are specified in Section 077200 "Roof Accessories."

PART 2 PRODUCTS

2.01 COPPER TUBE AND FITTINGS

- A. Copper Tube: ASTM B 88, Type K or L.
- B. Wrought-Copper Fittings: ASME B16.22.
- C. Wrought-Copper Unions: ASME B16.22.
- D. Solder Filler Metals: ASTM B 32. Use 95-5 tin antimony or alloy HB solder to join copper socket fittings on copper pipe.
- E. Brazing Filler Metals: AWS A5.8.
- F. Flexible Connectors:
 - 1. Body: Tin-bronze bellows with woven, flexible, tinned-bronze-wire-reinforced protective jacket.
 - 2. End Connections: Socket ends.
 - 3. Offset Performance: Capable of minimum 3/4-inch misalignment in minimum 7-inch-long assembly.
 - 4. Pressure Rating: Factory test at minimum 500 psig.
 - 5. Maximum Operating Temperature: 250 deg F.

2.02 VALVES AND SPECIALTIES

- A. Diaphragm Packless Valves:
 - 1. Body and Bonnet: Forged brass or cast bronze; globe design with straight-through or angle pattern.
 - 2. Diaphragm: Phosphor bronze and stainless steel with stainless-steel spring.
 - 3. Operator: Rising stem and hand wheel.
 - 4. Seat: Nylon.
 - 5. End Connections: Socket, union, or flanged.
 - 6. Working Pressure Rating: 500 psig.
 - 7. Maximum Operating Temperature: 275 deg F.
- B. Packed-Angle Valves:
 - 1. Body and Bonnet: Forged brass or cast bronze.
 - 2. Packing: Molded stem, back seating, and replaceable under pressure.
 - 3. Operator: Rising stem.
 - 4. Seat: Nonrotating, self-aligning polytetrafluoroethylene.
 - 5. Seal Cap: Forged-brass or valox hex cap.
 - 6. End Connections: solder
 - 7. Working Pressure Rating: 500 psig.
 - 8. Maximum Operating Temperature: 275 deg F.
- C. Check Valves:
 - 1. Body: Ductile iron, forged brass, or cast bronze; globe pattern.
 - 2. Bonnet: Bolted ductile iron, forged brass, or cast bronze; or brass hex plug.
 - 3. Piston: Removable polytetrafluoroethylene seat.
 - 4. Closing Spring: Stainless steel.
 - 5. Manual Opening Stem: Seal cap, plated-steel stem, and graphite seal.
 - 6. End Connections: solder
 - 7. Maximum Opening Pressure: 0.50 psig.
 - 8. Working Pressure Rating: 500 psig.
 - 9. Maximum Operating Temperature: 275 deg F.
- D. Service Valves:
 - 1. Body: Forged brass with brass cap including key end to remove core.
 - 2. Core: Removable ball-type check valve with stainless-steel spring.
 - 3. Seat: Polytetrafluoroethylene.
 - 4. End Connections: Copper spring.
 - 5. Working Pressure Rating: 500 psig.

- E. Solenoid Valves: Comply with ARI 760 and UL 429; listed and labeled by an NRTL.
 - 1. Body and Bonnet: Plated steel.
 - 2. Solenoid Tube, Plunger, Closing Spring, and Seat Orifice: Stainless steel.
 - 3. Seat: Polytetrafluoroethylene.
 - 4. End Connections: solder
 - 5. Electrical: Molded, watertight coil in NEMA 250 enclosure of type required by location with 1/2-inch conduit adapter, and 115 or 208-V ac coil.
 - 6. Working Pressure Rating: 400 psig.
 - 7. Maximum Operating Temperature: 240 deg F.
 - 8. Manual operator.
- F. Safety Relief Valves: Comply with ASME Boiler and Pressure Vessel Code; listed and labeled by an NRTL.
 - 1. Body and Bonnet: Ductile iron and steel, with neoprene O-ring seal.
 - 2. Piston, Closing Spring, and Seat Insert: Stainless steel.
 - 3. Seat Disc: Polytetrafluoroethylene.
 - 4. End Connections: solder
 - 5. Working Pressure Rating: 400 psig.
 - 6. Maximum Operating Temperature: 240 deg F.
- G. Thermostatic Expansion Valves: Comply with ARI 750.
 - 1. Body, Bonnet, and Seal Cap: Forged brass or steel.
 - 2. Diaphragm, Piston, Closing Spring, and Seat Insert: Stainless steel.
 - 3. Packing and Gaskets: Non-asbestos.
 - 4. Capillary and Bulb: Copper tubing filled with refrigerant charge.
 - 5. Suction Temperature: 40 deg F.
 - 6. Superheat: Adjustable.
 - 7. Reverse-flow option (for heat-pump applications).
 - 8. End Connections: solder
 - 9. Working Pressure Rating: 700 psig,450 psig.
- H. Hot-Gas Bypass Valves: Comply with UL 429; listed and labeled by an NRTL.
 - 1. Body, Bonnet, and Seal Cap: Ductile iron or steel.
 - 2. Diaphragm, Piston, Closing Spring, and Seat Insert: Stainless steel.
 - 3. Packing and Gaskets: Non-asbestos.
 - 4. Solenoid Tube, Plunger, Closing Spring, and Seat Orifice: Stainless steel.
 - 5. Seat: Polytetrafluoroethylene.
 - 6. Equalizer: External.
 - 7. Electrical: Molded, watertight coil in NEMA 250 enclosure of type required by location with 1/2-inchconduit adapter, and 115 or 208-V ac coil.
 - 8. End Connections: Socket.
 - 9. Set Pressure
 - 10. Throttling Range: Maximum 5 psig.
 - 11. Working Pressure Rating: 500 psig.
 - 12. Maximum Operating Temperature: 240 deg F.
- I. Straight-Type Strainers:
 - 1. Body: Welded steel with corrosion-resistant coating.
 - 2. Screen: 100-mesh stainless steel.
 - 3. End Connections: Socket or flare.
 - 4. Working Pressure Rating: 500 psig.
 - 5. Maximum Operating Temperature: 275 deg F.
- J. Angle-Type Strainers:
 - 1. Body: Forged brass or cast bronze.
 - 2. Drain Plug: Brass hex plug.
 - 3. Screen: 100-mesh monel.
 - 4. End Connections: Socket or flare.
 - 5. Working Pressure Rating: 500 psig.
 - 6. Maximum Operating Temperature: 275 deg F.

- K. Moisture/Liquid Indicators:
1. Body: Forged brass.
 2. Window: Replaceable, clear, fused glass window with indicating element protected by filter screen.
 3. Indicator: Color coded to show moisture content in ppm.
 4. Minimum Moisture Indicator Sensitivity: Indicate moisture above 60 ppm.
 5. End Connections: Socket or flare.
 6. Working Pressure Rating: 500 psig.
 7. Maximum Operating Temperature: 240 deg F.
- L. Replaceable-Core Filter Dryers: Comply with ARI 730.
1. Body and Cover: Painted-steel shell with ductile-iron cover, stainless-steel screws, and neoprene gaskets.
 2. Filter Media: 10 micron, pleated with integral end rings; stainless-steel support.
 3. Desiccant Media: Activated alumina or charcoal.
 4. Designed for reverse flow (for heat-pump applications).
 5. End Connections: Socket.
 6. Access Ports: NPS 1/4 connections at entering and leaving sides for pressure differential measurement.
 7. Maximum Pressure Loss: 2 psig.
 8. Rated Flow:
 9. Working Pressure Rating: 500 psig.
 10. Maximum Operating Temperature: 240 deg F.
- M. Permanent Filter Dryers: Comply with ARI 730.
1. Body and Cover: Painted-steel shell.
 2. Filter Media: 10 micron, pleated with integral end rings; stainless-steel support.
 3. Desiccant Media: Activated alumina or charcoal.
 4. Designed for reverse flow (for heat-pump applications).
 5. End Connections: Socket.
 6. Access Ports: NPS 1/4 connections at entering and leaving sides for pressure differential measurement.
 7. Maximum Pressure Loss: 2 psig.
 8. Rated Flow:
 9. Working Pressure Rating: 500 psig.
 10. Maximum Operating Temperature: 240 deg F.
- N. Mufflers:
1. Body: Welded steel with corrosion-resistant coating.
 2. End Connections: Socket or flare.
 3. Working Pressure Rating: 500 psig.
 4. Maximum Operating Temperature: 275 deg F.
- O. Receivers: Comply with ARI 495.
1. Comply with ASME Boiler and Pressure Vessel Code; listed and labeled by an NRTL.
 2. Comply with UL 207; listed and labeled by an NRTL.
 3. Body: Welded steel with corrosion-resistant coating.
 4. Tappings: Inlet, outlet, liquid level indicator, and safety relief valve.
 5. End Connections: solder
 6. Working Pressure Rating: 500 psig.
 7. Maximum Operating Temperature: 275 deg F.
- P. Liquid Accumulators: Comply with ARI 495.
1. Body: Welded steel with corrosion-resistant coating.
 2. End Connections: solder
 3. Working Pressure Rating: 500 psig.
 4. Maximum Operating Temperature: 275 deg F.

2.03 REFRIGERANTS

- A. ASHRAE 34, R-410A: Pentafluoroethane/Difluoromethane.

PART 3 EXECUTION**3.01 PIPING APPLICATIONS FOR REFRIGERANT R-410A**

- A. Suction Lines for Conventional Air-Conditioning Applications: Copper, Type K, drawn-temper tubing and wrought-copper fittings with soldered joints.
- B. Hot-Gas and Liquid Lines, and Suction Lines for Heat-Pump Applications: Copper, Type K, annealed- or drawn-temper tubing and wrought-copper fittings with brazed or soldered joints.
- C. Safety-Relief-Valve Discharge Piping: Copper, Type K, annealed- or drawn-temper tubing and wrought-copper fittings with brazed or soldered joints.

3.02 VALVE AND SPECIALTY APPLICATIONS

- A. Install diaphragm packless or packed-angle valves in suction and discharge lines of compressor.
- B. Install service valves for gage taps at inlet and outlet of hot-gas bypass valves and strainers if they are not an integral part of valves and strainers.
- C. Install a check valve at the compressor discharge and a liquid accumulator at the compressor suction connection.
- D. Except as otherwise indicated, install diaphragm packless or packed-angle valves on inlet and outlet side of filter dryers.
- E. Install a full-sized, three-valve bypass around filter dryers.
- F. Install solenoid valves upstream from each expansion valve and hot-gas bypass valve. Install solenoid valves in horizontal lines with coil at top.
- G. Install thermostatic expansion valves as close as possible to distributors on evaporators.
 - 1. Install valve so diaphragm case is warmer than bulb.
 - 2. Secure bulb to clean, straight, horizontal section of suction line using two bulb straps. Do not mount bulb in a trap or at bottom of the line.
 - 3. If external equalizer lines are required, make connection where it will reflect suction-line pressure at bulb location.
- H. Install safety relief valves where required by ASME Boiler and Pressure Vessel Code. Pipe safety-relief-valve discharge line to outside according to ASHRAE 15.
- I. Install moisture/liquid indicators in liquid line at the inlet of the thermostatic expansion valve or at the inlet of the evaporator coil capillary tube.
- J. Install strainers upstream from and adjacent to the following unless they are furnished as an integral assembly for device being protected:
 - 1. Solenoid valves.
 - 2. Thermostatic expansion valves.
 - 3. Hot-gas bypass valves.
 - 4. Compressor.
- K. Install filter dryers in liquid line between compressor and thermostatic expansion valve, and in the suction line at the compressor.
- L. Install receivers sized to accommodate pump-down charge.
- M. Install flexible connectors at compressors.

3.03 PIPING INSTALLATION

- A. Drawing plans, schematics, and diagrams indicate general location and arrangement of piping systems; indicated locations and arrangements were used to size pipe and calculate friction loss, expansion, pump sizing, and other design considerations. Install piping as indicated unless deviations to layout are approved on Shop Drawings.
- B. Install refrigerant piping according to ASHRAE 15.
- C. Install piping in concealed locations unless otherwise indicated and except in equipment rooms and service areas.

- D. Install piping indicated to be exposed and piping in equipment rooms and service areas at right angles or parallel to building walls. Diagonal runs are prohibited unless specifically indicated otherwise.
- E. Install piping above accessible ceilings to allow sufficient space for ceiling panel removal.
- F. Install piping adjacent to machines to allow service and maintenance.
- G. Install piping free of sags and bends.
- H. Install fittings for changes in direction and branch connections.
- I. Select system components with pressure rating equal to or greater than system operating pressure.
- J. Refer to Section 230900 "Instrumentation and Control for HVAC" and Section 230993 "Sequence of Operations for HVAC Controls" for solenoid valve controllers, control wiring, and sequence of operation.
- K. Install piping as short and direct as possible, with a minimum number of joints, elbows, and fittings.
- L. Arrange piping to allow inspection and service of refrigeration equipment. Install valves and specialties in accessible locations to allow for service and inspection. Install access doors or panels as specified in Section 083113 "Access Doors and Frames" if valves or equipment requiring maintenance is concealed behind finished surfaces.
- M. Install refrigerant piping in protective conduit where installed belowground.
- N. Install refrigerant piping in rigid or flexible conduit in locations where exposed to mechanical injury.
- O. Slope refrigerant piping as follows:
 - 1. Install horizontal hot-gas discharge piping with a uniform slope downward away from compressor.
 - 2. Install horizontal suction lines with a uniform slope downward to compressor.
 - 3. Install traps and double risers to entrain oil in vertical runs.
 - 4. Liquid lines may be installed level.
- P. When brazing or soldering, remove solenoid-valve coils and sight glasses; also remove valve stems, seats, and packing, and accessible internal parts of refrigerant specialties. Do not apply heat near expansion-valve bulb.
- Q. Before installation of steel refrigerant piping, clean pipe and fittings using the following procedures:
 - 1. Shot blast the interior of piping.
 - 2. Remove coarse particles of dirt and dust by drawing a clean, lintless cloth through tubing by means of a wire or electrician's tape.
 - 3. Draw a clean, lintless cloth saturated with trichloroethylene through the tube or pipe. Continue this procedure until cloth is not discolored by dirt.
 - 4. Draw a clean, lintless cloth, saturated with compressor oil, squeezed dry, through the tube or pipe to remove remaining lint. Inspect tube or pipe visually for remaining dirt and lint.
 - 5. Finally, draw a clean, dry, lintless cloth through the tube or pipe.
 - 6. Safety-relief-valve discharge piping is not required to be cleaned but is required to be open to allow unrestricted flow.
- R. Install piping with adequate clearance between pipe and adjacent walls and hangers or between pipes for insulation installation.
- S. Identify refrigerant piping and valves according to Section 230553 "Identification for HVAC Piping and Equipment."
- T. Install sleeves for piping penetrations of walls, ceilings, and floors. Comply with requirements for sleeves specified in Section 230517 "Sleeves and Sleeve Seals for HVAC Piping."
- U. Install sleeve seals for piping penetrations of concrete walls and slabs. Comply with

requirements for sleeve seals specified in Section 230517 "Sleeves and Sleeve Seals for HVAC Piping."

- V. Install escutcheons for piping penetrations of walls, ceilings, and floors. Comply with requirements for escutcheons specified in Section 230518 "Escutcheons for HVAC Piping."

3.04 PIPE JOINT CONSTRUCTION

- A. Ream ends of pipes and tubes and remove burrs. Bevel plain ends of steel pipe.
- B. Remove scale, slag, dirt, and debris from inside and outside of pipe and fittings before assembly.
- C. Fill pipe and fittings with an inert gas (nitrogen or carbon dioxide), during brazing or welding, to prevent scale formation.
- D. Soldered Joints: Construct joints according to ASTM B 828 or CDA's "Copper Tube Handbook."
- E. Brazed Joints: Construct joints according to AWS's "Brazing Handbook," Chapter "Pipe and Tube."
 - 1. Use Type BcuP, copper-phosphorus alloy for joining copper socket fittings with copper pipe.
 - 2. Use Type BAg, cadmium-free silver alloy for joining copper with bronze or steel.
- F. Welded Joints: Construct joints according to AWS D10.12/D10.12M.
- G. Flanged Joints: Select appropriate gasket material, size, type, and thickness for service application. Install gasket concentrically positioned. Use suitable lubricants on bolt threads.

3.05 HANGERS AND SUPPORTS

- A. Hanger, support, and anchor products are specified in Section 230529 "Hangers and Supports for HVAC Piping and Equipment."
- B. Install the following pipe attachments:
 - 1. Adjustable steel clevis hangers for individual horizontal runs less than 20 feetlong.
 - 2. Roller hangers and spring hangers for individual horizontal runs 20 feet or longer.
 - 3. Pipe Roller: MSS SP-58, Type 44 for multiple horizontal piping 20 feet or longer, supported on a trapeze.
 - 4. Spring hangers to support vertical runs.
 - 5. Copper-clad hangers and supports for hangers and supports in direct contact with copper pipe.
- C. Install hangers for copper tubing with the following maximum spacing and minimum rod sizes:
 - 1. NPS 1/2: Maximum span, 60 inches; minimum rod size, 1/4 inch.
 - 2. NPS 5/8: Maximum span, 60 inches; minimum rod size, 1/4 inch.
 - 3. NPS 1: Maximum span, 72 inches; minimum rod size, 1/4 inch.
 - 4. NPS 1-1/4: Maximum span, 96 inches; minimum rod size, 3/8 inch.
 - 5. NPS 1-1/2: Maximum span, 96 inches; minimum rod size, 3/8 inch.
 - 6. NPS 2: Maximum span, 96 inches; minimum rod size, 3/8 inch.
 - 7. NPS 2-1/2: Maximum span, 108 inches; minimum rod size, 3/8 inch.
 - 8. NPS 3: Maximum span, 10 feet; minimum rod size, 3/8 inch.
 - 9. NPS 4: Maximum span, 12 feet; minimum rod size, 1/2 inch.
- D. Support multi-floor vertical runs at least at each floor.

3.06 FIELD QUALITY CONTROL

- A. Perform tests and inspections and prepare test reports.
- B. Tests and Inspections:
 - 1. Comply with ASME B31.5, Chapter VI.
 - 2. Test refrigerant piping, specialties, and receivers. Isolate compressor,

condenser, evaporator, and safety devices from test pressure if they are not rated above the test pressure.

3. Test high- and low-pressure side piping of each system separately at not less than the pressures indicated in Part 1 "Performance Requirements" Article.
 - a. Fill system with nitrogen to the required test pressure.
 - b. System shall maintain test pressure at the manifold gage throughout duration of test.
 - c. Test joints and fittings with electronic leak detector or by brushing a small amount of soap and glycerin solution over joints.
 - d. Remake leaking joints using new materials, and retest until satisfactory results are achieved.

3.07 SYSTEM CHARGING

- A. Charge system using the following procedures:
 1. Install core in filter dryers after leak test but before evacuation.
 2. Evacuate entire refrigerant system with a vacuum pump to 500 micrometers. If vacuum holds for 12 hours, system is ready for charging.
 3. Break vacuum with refrigerant gas, allowing pressure to build up to 2 psig.
 4. Charge system with a new filter-dryer core in charging line.

3.08 ADJUSTING

- A. Adjust thermostatic expansion valve to obtain proper evaporator superheat.
- B. Adjust high- and low-pressure switch settings to avoid short cycling in response to fluctuating suction pressure.
- C. Adjust set-point temperature of air-conditioning or chilled-water controllers to the system design temperature.
- D. Perform the following adjustments before operating the refrigeration system, according to manufacturer's written instructions:
 1. Open shutoff valves in condenser water circuit.
 2. Verify that compressor oil level is correct.
 3. Open compressor suction and discharge valves.
 4. Open refrigerant valves except bypass valves that are used for other purposes.
 5. Check open compressor-motor alignment and verify lubrication for motors and bearings.
- E. Replace core of replaceable filter dryer after system has been adjusted and after design flow rates and pressures are established.

END OF SECTION

SECTION 23 31 13**METAL DUCTS****PART 1 GENERAL****1.01 RELATED DOCUMENTS**

- A. Drawings and general provisions of the Contract, including General and Supplementary Conditions and Division 01 Specification Sections, apply to this Section.

1.02 SUMMARY

- A. Section Includes:
 - 1. Single-wall rectangular ducts and fittings.
 - 2. Single-wall round ducts and fittings.
 - 3. Sheet metal materials.
 - 4. Sealants and gaskets.
 - 5. Hangers and supports.
 - 6. Seismic-restraint devices.
- B. Related Sections:
 - 1. Section 230593 "Testing, Adjusting, and Balancing for HVAC" for testing, adjusting, and balancing requirements for metal ducts.
 - 2. Section 233300 "Air Duct Accessories" for dampers, sound-control devices, duct-mounting access doors and panels, turning vanes, and flexible ducts.

1.03 PERFORMANCE REQUIREMENTS

- A. Delegated Duct Design: Duct construction, including sheet metal thicknesses, seam and joint construction, reinforcements, and hangers and supports, shall comply with SMACNA's "HVAC Duct Construction Standards - Metal and Flexible" and performance requirements and design criteria indicated in "Duct Schedule" Article.
- B. Structural Performance: Duct hangers and supports and seismic restraints shall withstand the effects of gravity and seismic loads and stresses within limits and under conditions described in SMACNA's "HVAC Duct Construction Standards - Metal and Flexible" and ASCE/SEI 7. And SMACNA's "Seismic Restraint Manual: Guidelines for Mechanical Systems."
 - 1. Seismic Hazard Level A: Seismic force to weight ratio, 0.48.
 - 2. Seismic Hazard Level B: Seismic force to weight ratio, 0.30.
 - 3. Seismic Hazard Level C: Seismic force to weight ratio, 0.15.
- C. Airstream Surfaces: Surfaces in contact with the airstream shall comply with requirements in ASHRAE 62.1.

1.04 ACTION SUBMITTALS

- A. Product Data: For each type of the following products:
 - 1. Liners and adhesives.
 - 2. Sealants and gaskets.
 - 3. Seismic-restraint devices.
- B. Shop Drawings:
 - 1. Fabrication, assembly, and installation, including plans, elevations, sections, components, and attachments to other work.
 - 2. Factory- and shop-fabricated ducts and fittings.
 - 3. Duct layout indicating sizes, configuration, liner material, and static-pressure classes.
 - 4. Elevation of top of ducts.
 - 5. Dimensions of main duct runs from building grid lines.
 - 6. Fittings.
 - 7. Reinforcement and spacing.
 - 8. Seam and joint construction.
 - 9. Penetrations through fire-rated and other partitions.
 - 10. Equipment installation based on equipment being used on Project.

11. Locations for duct accessories, including dampers, turning vanes, and access doors and panels.
 12. Hangers and supports, including methods for duct and building attachment, seismic restraints, and vibration isolation.
- C. Delegated-Design Submittal:
1. Sheet metal thicknesses.
 2. Joint and seam construction and sealing.
 3. Reinforcement details and spacing.
 4. Materials, fabrication, assembly, and spacing of hangers and supports.
 5. Design Calculations: Calculations, including analysis data signed and sealed by the qualified professional engineer responsible for their preparation for selecting hangers and supports and seismic restraints.

1.05 INFORMATIONAL SUBMITTALS

- A. Coordination Drawings: Plans, drawn to scale, on which the following items are shown and coordinated with each other, using input from installers of the items involved:
1. Duct installation in congested spaces, indicating coordination with general construction, building components, and other building services. Indicate proposed changes to duct layout.
 2. Suspended ceiling components.
 3. Structural members to which duct will be attached.
 4. Size and location of initial access modules for acoustical tile.
 5. Penetrations of smoke barriers and fire-rated construction.
 6. Items penetrating finished ceiling including the following:
 - a. Lighting fixtures.
 - b. Air outlets and inlets.
 - c. Speakers.
 - d. Sprinklers.
 - e. Access panels.
 - f. Perimeter moldings.
- B. Welding certificates.
- C. Field quality-control reports.

1.06 QUALITY ASSURANCE

- A. Welding Qualifications: Qualify procedures and personnel according to AWS D1.1/D1.1M, "Structural Welding Code - Steel," for hangers and supports. AWS D1.2/D1.2M, "Structural Welding Code - Aluminum," for aluminum supports. AWS D9.1M/D9.1, "Sheet Metal Welding Code," for duct joint and seam welding.
- B. Welding Qualifications: Qualify procedures and personnel according to the following:
1. AWS D1.1/D1.1M, "Structural Welding Code - Steel," for hangers and supports.
 2. AWS D1.2/D1.2M, "Structural Welding Code - Aluminum," for aluminum supports.
 3. AWS D9.1M/D9.1, "Sheet Metal Welding Code," for duct joint and seam welding.
- C. ASHRAE Compliance: Applicable requirements in ASHRAE 62.1, Section 5 - "Systems and Equipment" and Section 7 - "Construction and System Start-up."
- D. ASHRAE/IESNA Compliance: Applicable requirements in ASHRAE/IESNA 90.1, Section 6.4.4 - "HVAC System Construction and Insulation."

PART 2 PRODUCTS

2.01 SINGLE-WALL RECTANGULAR DUCTS AND FITTINGS

- A. General Fabrication Requirements: Comply with SMACNA's "HVAC Duct Construction Standards - Metal and Flexible" based on indicated static-pressure class unless otherwise indicated.
- B. Transverse Joints: Select joint types and fabricate according to SMACNA's "HVAC Duct Construction Standards - Metal and Flexible," Figure 2-1, "Rectangular Duct/Transverse

Joints," for static-pressure class, applicable sealing requirements, materials involved, duct-support intervals, and other provisions in SMACNA's "HVAC Duct Construction Standards - Metal and Flexible."

- C. Longitudinal Seams: Select seam types and fabricate according to SMACNA's "HVAC Duct Construction Standards - Metal and Flexible," Figure 2-2, "Rectangular Duct/Longitudinal Seams," for static-pressure class, applicable sealing requirements, materials involved, duct-support intervals, and other provisions in SMACNA's "HVAC Duct Construction Standards - Metal and Flexible."
- D. Elbows, Transitions, Offsets, Branch Connections, and Other Duct Construction: Select types and fabricate according to SMACNA's "HVAC Duct Construction Standards - Metal and Flexible," Chapter 4, "Fittings and Other Construction," for static-pressure class, applicable sealing requirements, materials involved, duct-support intervals, and other provisions in SMACNA's "HVAC Duct Construction Standards - Metal and Flexible."

2.02 SINGLE-WALL ROUND DUCTS AND FITTINGS

- A. General Fabrication Requirements: Comply with SMACNA's "HVAC Duct Construction Standards - Metal and Flexible," Chapter 3, "Round, Oval, and Flexible Duct," based on indicated static-pressure class unless otherwise indicated.
 - 1. Manufacturers: Subject to compliance with requirements, available manufacturers offering products that may be incorporated into the Work include, but are not limited to, the following:
 - a. Lindab Inc.
 - b. McGill AirFlow LLC.
 - c. SEMCO Incorporated.
 - d. Sheet Metal Connectors, Inc.
 - e. Spiral Manufacturing Co., Inc.
- B. Transverse Joints: Select joint types and fabricate according to SMACNA's "HVAC Duct Construction Standards - Metal and Flexible," Figure 3-1, "Round Duct Transverse Joints," for static-pressure class, applicable sealing requirements, materials involved, duct-support intervals, and other provisions in SMACNA's "HVAC Duct Construction Standards - Metal and Flexible."
 - 1. Transverse Joints in Ducts Larger Than 60 Inches in Diameter: Flanged.
- C. Longitudinal Seams: Select seam types and fabricate according to SMACNA's "HVAC Duct Construction Standards - Metal and Flexible," Figure 3-2, "Round Duct Longitudinal Seams," for static-pressure class, applicable sealing requirements, materials involved, duct-support intervals, and other provisions in SMACNA's "HVAC Duct Construction Standards - Metal and Flexible."
 - 1. Fabricate round ducts larger than 90 inches in diameter with butt-welded longitudinal seams.
 - 2. Fabricate flat-oval ducts larger than 72 inches in width (major dimension) with butt-welded longitudinal seams.
- D. Tees and Laterals: Select types and fabricate according to SMACNA's "HVAC Duct Construction Standards - Metal and Flexible," Figure 3-5, "90 Degree Tees and Laterals," and Figure 3-6, "Conical Tees," for static-pressure class, applicable sealing requirements, materials involved, duct-support intervals, and other provisions in SMACNA's "HVAC Duct Construction Standards - Metal and Flexible."
- E. Snap lock type duct can be used for low pressure applications.

2.03 SHEET METAL MATERIALS

- A. General Material Requirements: Comply with SMACNA's "HVAC Duct Construction Standards - Metal and Flexible" for acceptable materials, material thicknesses, and duct construction methods unless otherwise indicated. Sheet metal materials shall be free of pitting, seam marks, roller marks, stains, discolorations, and other imperfections.
- B. Galvanized Sheet Steel: Comply with ASTM A 653/A 653M.
 - 1. Galvanized Coating Designation: G60 or G90.

2. Finishes for Surfaces Exposed to View: Mill phosphatized.
- C. PVC-Coated, Galvanized Sheet Steel: Comply with ASTM A 653/A 653M.
 1. Galvanized Coating Designation: G60 or G90.
 2. Minimum Thickness for Factory-Applied PVC Coating: 4 mils thick on sheet metal surface of ducts and fittings exposed to corrosive conditions, and minimum 1 mil thick on opposite surface.
 3. Coating Materials: Acceptable to authorities having jurisdiction for use on ducts listed and labeled by an NRTL for compliance with UL 181, Class 1.
- D. Carbon-Steel Sheets: Comply with ASTM A 1008/A 1008M, with oiled, matte finish for exposed ducts.
- E. Stainless-Steel Sheets: Comply with ASTM A 480/A 480M, Type 304 or 316, as indicated in the "Duct Schedule" Article; cold rolled, annealed, sheet. Exposed surface finish shall be No. 2B, No. 2D, No. 3, or No. 4 as indicated in the "Duct Schedule" Article.
- F. Aluminum Sheets: Comply with ASTM B 209 Alloy 3003, H14 temper; with mill finish for concealed ducts, and standard, one-side bright finish for duct surfaces exposed to view.
- G. Factory- or Shop-Applied Antimicrobial Coating:
 1. Apply to the surface of sheet metal that will form the interior surface of the duct. An untreated clear coating shall be applied to the exterior surface.
 2. Antimicrobial compound shall be tested for efficacy by an NRTL and registered by the EPA for use in HVAC systems.
 3. Coating containing the antimicrobial compound shall have a hardness of 2H, minimum, when tested according to ASTM D 3363.
 4. Surface-Burning Characteristics: Maximum flame-spread index of 25 and maximum smoke-developed index of 50 when tested according to UL 723; certified by an NRTL.
 5. Shop-Applied Coating Color: Black or White.
 6. Antimicrobial coating on sheet metal is not required for duct containing liner treated with antimicrobial coating.
- H. Reinforcement Shapes and Plates: ASTM A 36/A 36M, steel plates, shapes, and bars; black and galvanized.
 1. Where black- and galvanized-steel shapes and plates are used to reinforce aluminum ducts, isolate the different metals with butyl rubber, neoprene, or EPDM gasket materials.
- I. Tie Rods: Galvanized steel, 1/4-inch minimum diameter for lengths 36 inches or less; 3/8-inch minimum diameter for lengths longer than 36 inches.

2.04 SEALANT AND GASKETS

- A. General Sealant and Gasket Requirements: Surface-burning characteristics for sealants and gaskets shall be a maximum flame-spread index of 25 and a maximum smoke-developed index of 50 when tested according to UL 723; certified by an NRTL.
- B. Two-Part Tape Sealing System:
 1. Tape: Woven cotton fiber impregnated with mineral gypsum and modified acrylic/silicone activator to react exothermically with tape to form hard, durable, airtight seal.
 2. Tape Width: 4 inches.
 3. Sealant: Modified styrene acrylic.
 4. Water resistant.
 5. Mold and mildew resistant.
 6. Maximum Static-Pressure Class: 10-inch wg, positive and negative.
 7. Service: Indoor and outdoor.
 8. Service Temperature: Minus 40 to plus 200 deg F.
 9. Substrate: Compatible with galvanized sheet steel (both PVC coated and bare), stainless steel, or aluminum.
 10. For indoor applications, sealant shall have a VOC content of 250 g/L or less when calculated according to 40 CFR 59, Subpart D (EPA Method 24).

11. Sealant shall comply with the testing and product requirements of the California Department of Health Services' "Standard Practice for the Testing of Volatile Organic Emissions from Various Sources Using Small-Scale Environmental Chambers."
- C. Water-Based Joint and Seam Sealant:
1. Application Method: Brush on.
 2. Solids Content: Minimum 65 percent.
 3. Shore A Hardness: Minimum 20.
 4. Water resistant.
 5. Mold and mildew resistant.
 6. VOC: Maximum 75 g/L (less water).
 7. Maximum Static-Pressure Class: 10-inch wg, positive and negative.
 8. Service: Indoor or outdoor.
 9. Substrate: Compatible with galvanized sheet steel (both PVC coated and bare), stainless steel, or aluminum sheets.
- D. Solvent-Based Joint and Seam Sealant:
1. Application Method: Brush on.
 2. Base: Synthetic rubber resin.
 3. Solvent: Toluene and heptane.
 4. Solids Content: Minimum 60 percent.
 5. Shore A Hardness: Minimum 60.
 6. Water resistant.
 7. Mold and mildew resistant.
 8. For indoor applications, sealant shall have a VOC content of 250 g/L or less when calculated according to 40 CFR 59, Subpart D (EPA Method 24).
 9. VOC: Maximum 395 g/L.
 10. Sealant shall comply with the testing and product requirements of the California Department of Health Services' "Standard Practice for the Testing of Volatile Organic Emissions from Various Sources Using Small-Scale Environmental Chambers."
 11. Maximum Static-Pressure Class: 10-inch wg, positive or negative.
 12. Service: Indoor or outdoor.
 13. Substrate: Compatible with galvanized sheet steel (both PVC coated and bare), stainless steel, or aluminum sheets.
- E. Flanged Joint Sealant: Comply with ASTM C 920.
1. General: Single-component, acid-curing, silicone, elastomeric.
 2. Type: S.
 3. Grade: NS.
 4. Class: 25.
 5. Use: O.
 6. For indoor applications, sealant shall have a VOC content of 250 g/L or less when calculated according to 40 CFR 59, Subpart D (EPA Method 24).
 7. Sealant shall comply with the testing and product requirements of the California Department of Health Services' "Standard Practice for the Testing of Volatile Organic Emissions from Various Sources Using Small-Scale Environmental Chambers."
- F. Flange Gaskets: Butyl rubber, neoprene, or EPDM polymer with polyisobutylene plasticizer.
- G. Round Duct Joint O-Ring Seals:
1. Seal shall provide maximum leakage class of 3 cfm/100 sq. ft. at 1-inch wg and shall be rated for 10-inch wg static-pressure class, positive or negative.
 2. EPDM O-ring to seal in concave bead in coupling or fitting spigot.
 3. Double-lipped, EPDM O-ring seal, mechanically fastened to factory-fabricated couplings and fitting spigots.

2.05 HANGERS AND SUPPORTS

- A. Hanger Rods for Noncorrosive Environments: Cadmium-plated steel rods and nuts.
- B. Hanger Rods for Corrosive Environments: Electrogalvanized, all-thread rods or galvanized rods with threads painted with zinc-chromate primer after installation.
- C. Strap and Rod Sizes: Comply with SMACNA's "HVAC Duct Construction Standards - Metal and Flexible," Table 5-1, "Rectangular Duct Hangers Minimum Size," and Table 5-2, "Minimum Hanger Sizes for Round Duct."
- D. Steel Cables for Galvanized-Steel Ducts: Galvanized steel complying with ASTM A 603.
- E. Steel Cables for Stainless-Steel Ducts: Stainless steel complying with ASTM A 492.
- F. Steel Cable End Connections: Cadmium-plated steel assemblies with brackets, swivel, and bolts designed for duct hanger service; with an automatic-locking and clamping device.
- G. Duct Attachments: Sheet metal screws, blind rivets, or self-tapping metal screws; compatible with duct materials.
- H. Trapeze and Riser Supports:
 - 1. Supports for Galvanized-Steel Ducts: Galvanized-steel shapes and plates.
 - 2. Supports for Stainless-Steel Ducts: Stainless-steel shapes and plates.
 - 3. Supports for Aluminum Ducts: Aluminum or galvanized steel coated with zinc chromate.

2.06 SEISMIC-RESTRAINT DEVICES

- A. Manufacturers: Subject to compliance with requirements, available manufacturers offering products that may be incorporated into the Work include, but are not limited to, the following:
 - 1. Cooper B-Line, Inc.; a division of Cooper Industries.
 - 2. Ductmate Industries, Inc.
 - 3. Hilti Corp.
 - 4. Kinetics Noise Control.
 - 5. Loos & Co.; Cableware Division.
 - 6. Mason Industries.
 - 7. TOLCO; a brand of NIBCO INC.
 - 8. Unistrut Corporation; Tyco International, Ltd.
- B. General Requirements for Restraint Components: Rated strengths, features, and applications shall be as defined in reports by an evaluation service member of the ICC Evaluation Service, the Office of Statewide Health Planning and Development for the State of California, or an agency acceptable to authorities having jurisdiction.
 - 1. Structural Safety Factor: Allowable strength in tension, shear, and pullout force of components shall be at least four times the maximum seismic forces to which they will be subjected.
- C. Channel Support System: Shop- or field-fabricated support assembly made of slotted steel channels rated in tension, compression, and torsion forces and with accessories for attachment to braced component at one end and to building structure at the other end. Include matching components and corrosion-resistant coating.
- D. Restraint Cables: ASTM A 492, stainless-steel cables with end connections made of cadmium-plated steel assemblies with brackets, swivel, and bolts designed for restraining cable service; and with an automatic-locking and clamping device or double-cable clips.
- E. Hanger Rod Stiffener: Steel tube or steel slotted-support-system sleeve with internally bolted connections or Reinforcing steel angle clamped to hanger rod.
- F. Mechanical Anchor Bolts: Drilled-in and stud-wedge or female-wedge type. Select anchor bolts with strength required for anchor and as tested according to ASTM E 488.

PART 3 EXECUTION

3.01 DUCT INSTALLATION

- A. Drawing plans, schematics, and diagrams indicate general location and arrangement of

duct system. Indicated duct locations, configurations, and arrangements were used to size ducts and calculate friction loss for air-handling equipment sizing and for other design considerations. Install duct systems as indicated unless deviations to layout are approved on Shop Drawings and Coordination Drawings.

- B. Install ducts according to SMACNA's "HVAC Duct Construction Standards - Metal and Flexible" unless otherwise indicated.
- C. Install round and flat-oval ducts in maximum practical lengths.
- D. Install ducts with fewest possible joints.
- E. Install factory- or shop-fabricated fittings for changes in direction, size, and shape and for branch connections.
- F. Unless otherwise indicated, install ducts vertically and horizontally, and parallel and perpendicular to building lines.
- G. Install ducts close to walls, overhead construction, columns, and other structural and permanent enclosure elements of building.
- H. Install ducts with a clearance of 1 inch, plus allowance for insulation thickness.
- I. Route ducts to avoid passing through transformer vaults and electrical equipment rooms and enclosures.
- J. Where ducts pass through non-fire-rated interior partitions and exterior walls and are exposed to view, cover the opening between the partition and duct or duct insulation with sheet metal flanges of same metal thickness as the duct. Overlap openings on four sides by at least 1-1/2 inches.
- K. Where ducts pass through fire-rated interior partitions and exterior walls, install fire dampers. Comply with requirements in Section 233300 "Air Duct Accessories" for fire and smoke dampers.
- L. Protect duct interiors from moisture, construction debris and dust, and other foreign materials. Comply with SMACNA's "IAQ Guidelines for Occupied Buildings Under Construction," Appendix G, "Duct Cleanliness for New Construction Guidelines."

3.02 DUCT SEALING

- A. Seal ducts for duct static-pressure, seal classes, and leakage classes specified in "Duct Schedule" Article according to SMACNA's "HVAC Duct Construction Standards - Metal and Flexible."
- B. Seal ducts to the following seal classes according to SMACNA's "HVAC Duct Construction Standards - Metal and Flexible":
 - 1. Comply with SMACNA's "HVAC Duct Construction Standards - Metal and Flexible."
 - 2. Unconditioned Space, Supply-Air Ducts in Pressure Classes 2-Inch wg and Lower: Seal Class B.
 - 3. Unconditioned Space, Supply-Air Ducts in Pressure Classes Higher Than 2-Inch wg: Seal Class A.
 - 4. Unconditioned Space, Exhaust Ducts: Seal Class C.
 - 5. Unconditioned Space, Return-Air Ducts: Seal Class B.
 - 6. Conditioned Space, Supply-Air Ducts in Pressure Classes 2-Inch wg and Lower: Seal Class C.
 - 7. Conditioned Space, Supply-Air Ducts in Pressure Classes Higher Than 2-Inch wg: Seal Class B.
 - 8. Conditioned Space, Exhaust Ducts: Seal Class B.
 - 9. Conditioned Space, Return-Air Ducts: Seal Class C.

3.03 HANGER AND SUPPORT INSTALLATION

- A. Comply with SMACNA's "HVAC Duct Construction Standards - Metal and Flexible," Chapter 5, "Hangers and Supports."
- B. Building Attachments: Concrete inserts, powder-actuated fasteners, or structural-steel

- fasteners appropriate for construction materials to which hangers are being attached.
1. Where practical, install concrete inserts before placing concrete.
 2. Install powder-actuated concrete fasteners after concrete is placed and completely cured.
 3. Use powder-actuated concrete fasteners for standard-weight aggregate concretes or for slabs more than 4 inches thick.
 4. Do not use powder-actuated concrete fasteners for lightweight-aggregate concretes or for slabs less than 4 inches thick.
 5. Do not use powder-actuated concrete fasteners for seismic restraints.
- C. Hanger Spacing: Comply with SMACNA's "HVAC Duct Construction Standards - Metal and Flexible," Table 5-1, "Rectangular Duct Hangers Minimum Size," and Table 5-2, "Minimum Hanger Sizes for Round Duct," for maximum hanger spacing; install hangers and supports within 24 inches of each elbow and within 48 inches of each branch intersection.
- D. Hangers Exposed to View: Threaded rod and angle or channel supports.
- E. Support vertical ducts with steel angles or channel secured to the sides of the duct with welds, bolts, sheet metal screws, or blind rivets; support at each floor and at a maximum interval of 16 feet.
- F. Install upper attachments to structures. Select and size upper attachments with pull-out, tension, and shear capacities appropriate for supported loads and building materials where used.

3.04 SEISMIC-RESTRAINT-DEVICE INSTALLATION

- A. Install ducts with hangers and braces designed to support the duct and to restrain against seismic forces required by applicable building codes. Comply with SMACNA's "Seismic Restraint Manual: Guidelines for Mechanical Systems." ASCE/SEI 7.
1. Space lateral supports a maximum of 40 feet o.c., and longitudinal supports a maximum of 80 feet o.c.
 2. Brace a change of direction longer than 12 feet.
- B. Select seismic-restraint devices with capacities adequate to carry present and future static and seismic loads.
- C. Install cables so they do not bend across edges of adjacent equipment or building structure.
- D. Install cable restraints on ducts that are suspended with vibration isolators.
- E. Install seismic-restraint devices using methods approved by an evaluation service member of the ICC Evaluation Service, the Office of Statewide Health Planning and Development for the State of California, an agency acceptable to authorities having jurisdiction.
- F. Attachment to Structure: If specific attachment is not indicated, anchor bracing and restraints to structure, to flanges of beams, to upper truss chords of bar joists, or to concrete members.
- G. Drilling for and Setting Anchors:
1. Identify position of reinforcing steel and other embedded items prior to drilling holes for anchors. Do not damage existing reinforcement or embedded items during drilling. Notify the Architect if reinforcing steel or other embedded items are encountered during drilling. Locate and avoid prestressed tendons, electrical and telecommunications conduit, and gas lines.
 2. Do not drill holes in concrete or masonry until concrete, mortar, or grout has achieved full design strength.
 3. Wedge Anchors: Protect threads from damage during anchor installation. Heavy-duty sleeve anchors shall be installed with sleeve fully engaged in the structural element to which anchor is to be fastened.
 4. Set anchors to manufacturer's recommended torque, using a torque wrench.

5. Install zinc-coated steel anchors for interior applications and stainless-steel anchors for applications exposed to weather.

3.05 CONNECTIONS

- A. Make connections to equipment with flexible connectors complying with Section 233300 "Air Duct Accessories."
- B. Comply with SMACNA's "HVAC Duct Construction Standards - Metal and Flexible" for branch, outlet and inlet, and terminal unit connections.

3.06 FIELD QUALITY CONTROL

- A. Perform tests and inspections.
- B. Leakage Tests:
 1. Comply with SMACNA's "HVAC Air Duct Leakage Test Manual." Submit a test report for each test.
 2. Test the following systems:
 - a. Ducts with a Pressure Class Higher Than 3-Inch wg: Test representative duct sections, selected by Architect from sections installed, totaling no less than 25 percent of total installed duct area for each designated pressure class.
 - b. Supply Ducts with a Pressure Class of 2-Inch wg or Higher: Test representative duct sections, selected by Architect from sections installed, totaling no less than 50 percent of total installed duct area for each designated pressure class.
 - c. Return Ducts with a Pressure Class of 2-Inch wg or Higher: Test representative duct sections, selected by Architect from sections installed, totaling no less than 50 percent of total installed duct area for each designated pressure class.
 - d. Exhaust Ducts with a Pressure Class of 2-Inch wg or Higher: Test representative duct sections, selected by Architect from sections installed, totaling no less than 50 percent of total installed duct area for each designated pressure class.
 - e. Outdoor Air Ducts with a Pressure Class of 2-Inch wg or Higher: Test representative duct sections, selected by Architect from sections installed, totaling no less than 50 percent of total installed duct area for each designated pressure class.
 3. Disassemble, reassemble, and seal segments of systems to accommodate leakage testing and for compliance with test requirements.
 4. Test for leaks before applying external insulation.
 5. Conduct tests at static pressures equal to maximum design pressure of system or section being tested. If static-pressure classes are not indicated, test system at maximum system design pressure. Do not pressurize systems above maximum design operating pressure.
 6. Give seven days' advance notice for testing.
- C. Duct System Cleanliness Tests:
 1. Visually inspect duct system to ensure that no visible contaminants are present.
 2. Test sections of metal duct system, chosen randomly by Owner, for cleanliness according to "Vacuum Test" in NADCA ACR, "Assessment, Cleaning and Restoration of HVAC Systems."
 - a. Acceptable Cleanliness Level: Net weight of debris collected on the filter media shall not exceed 0.75 mg/100 sq. cm.
- D. Duct system will be considered defective if it does not pass tests and inspections.
- E. Prepare test and inspection reports.

3.07 START UP

- A. Air Balance: Comply with requirements in Section 230593 "Testing, Adjusting, and Balancing for HVAC."

3.08 DUCT SCHEDULE

- A. Fabricate ducts with galvanized sheet steel except as otherwise indicated.
- B. Supply Ducts:
 - 1. Ducts Connected to Fan Coil Units, Furnaces, Heat Pumps, and Terminal Units:
 - a. Pressure Class: Positive 2-inch wg.
 - b. Minimum SMACNA Seal Class: A.
 - c. SMACNA Leakage Class for Rectangular: 12.
 - d. SMACNA Leakage Class for Round and Flat Oval: 12.
 - 2. Ducts Connected to Constant-Volume Air-Handling Units:
 - a. Pressure Class: Positive 3-inch wg.
 - b. Minimum SMACNA Seal Class: A.
 - c. SMACNA Leakage Class for Rectangular: 6.
 - d. SMACNA Leakage Class for Round and Flat Oval: 6.
 - 3. Ducts Connected to Equipment Not Listed Above:
 - a. Pressure Class: Positive 2-inch wg.
 - b. Minimum SMACNA Seal Class: A.
 - c. SMACNA Leakage Class for Rectangular: 6.
 - d. SMACNA Leakage Class for Round and Flat Oval: 3.
- C. Return Ducts:
 - 1. Ducts Connected to Fan Coil Units, Furnaces, Heat Pumps, and Terminal Units:
 - a. Pressure Class: Positive or negative 2-inch wg.
 - b. Minimum SMACNA Seal Class: A.
 - c. SMACNA Leakage Class for Rectangular: 12.
 - d. SMACNA Leakage Class for Round and Flat Oval: 12.
 - 2. Ducts Connected to Air-Handling Units:
 - a. Pressure Class: Positive or negative 2-inch wg.
 - b. Minimum SMACNA Seal Class: A.
 - c. SMACNA Leakage Class for Rectangular: 6.
 - d. SMACNA Leakage Class for Round and Flat Oval: 6.
 - 3. Ducts Connected to Equipment Not Listed Above:
 - a. Pressure Class: Positive or negative 2-inch wg.
 - b. Minimum SMACNA Seal Class: A.
 - c. SMACNA Leakage Class for Rectangular: 3.
 - d. SMACNA Leakage Class for Round and Flat Oval: 3.
- D. Intermediate Reinforcement:
 - 1. Galvanized-Steel Ducts: Galvanized steel.
 - 2. PVC-Coated Ducts:
 - a. Exposed to Airstream: Match duct material.
 - b. Not Exposed to Airstream: Match duct material.
 - 3. Stainless-Steel Ducts:
 - a. Exposed to Airstream: Match duct material.
 - b. Not Exposed to Airstream: Match duct material.
 - 4. Aluminum Ducts: Aluminum.
- E. Elbow Configuration:
 - 1. Rectangular Duct: Comply with SMACNA's "HVAC Duct Construction Standards - Metal and Flexible," Figure 4-2, "Rectangular Elbows."
 - a. Velocity 1000 fpm or Lower:
 - 1) Radius Type RE 1 with minimum 0.5 radius-to-diameter ratio.
 - 2) Mitered Type RE 4 without vanes.
 - b. Velocity 1000 to 1500 fpm:
 - 1) Radius Type RE 1 with minimum 1.0 radius-to-diameter ratio.
 - 2) Radius Type RE 3 with minimum 0.5 radius-to-diameter ratio and two vanes.
 - 3) Mitered Type RE 2 with vanes complying with SMACNA's "HVAC Duct Construction Standards - Metal and Flexible," Figure 4-3,

- "Vaness and Vane Runners," and Figure 4-4, "Vane Support in Elbows."
- c. Velocity 1500 fpm or Higher:
 - 1) Radius Type RE 1 with minimum 1.5 radius-to-diameter ratio.
 - 2) Radius Type RE 3 with minimum 1.0 radius-to-diameter ratio and two vanes.
 - 3) Mitered Type RE 2 with vanes complying with SMACNA's "HVAC Duct Construction Standards - Metal and Flexible," Figure 4-3, "Vaness and Vane Runners," and Figure 4-4, "Vane Support in Elbows."
 2. Rectangular Duct: Comply with SMACNA's "HVAC Duct Construction Standards - Metal and Flexible," Figure 4-2, "Rectangular Elbows."
 - a. Radius Type RE 1 with minimum 1.5 radius-to-diameter ratio.
 - b. Radius Type RE 3 with minimum 1.0 radius-to-diameter ratio and two vanes.
 - c. Mitered Type RE 2 with vanes complying with SMACNA's "HVAC Duct Construction Standards - Metal and Flexible," Figure 4-3, "Vaness and Vane Runners," and Figure 4-4, "Vane Support in Elbows."
 3. Round Duct: Comply with SMACNA's "HVAC Duct Construction Standards - Metal and Flexible," Figure 3-4, "Round Duct Elbows."
 - a. Minimum Radius-to-Diameter Ratio and Elbow Segments: Comply with SMACNA's "HVAC Duct Construction Standards - Metal and Flexible," Table 3-1, "Mitered Elbows." Elbows with less than 90-degree change of direction have proportionately fewer segments.
 - 1) Velocity 1000 fpm or Lower: 0.5 radius-to-diameter ratio and three segments for 90-degree elbow.
 - 2) Velocity 1000 to 1500 fpm: 1.0 radius-to-diameter ratio and four segments for 90-degree elbow.
 - 3) Velocity 1500 fpm or Higher: 1.5 radius-to-diameter ratio and five segments for 90-degree elbow.
 - 4) Radius-to Diameter Ratio: 1.5.
 - b. Round Elbows, 12 Inches and Smaller in Diameter: Stamped or pleated.
 - c. Round Elbows, 14 Inches and Larger in Diameter: Standing seam or Welded.
- F. Branch Configuration:
1. Rectangular Duct: Comply with SMACNA's "HVAC Duct Construction Standards - Metal and Flexible," Figure 4-6, "Branch Connection."
 - a. Rectangular Main to Rectangular Branch: 45-degree entry.
 - b. Rectangular Main to Round Branch: Spin in.
 2. Round and Flat Oval: Comply with SMACNA's "HVAC Duct Construction Standards - Metal and Flexible," Figure 3-5, "90 Degree Tees and Laterals," and Figure 3-6, "Conical Tees." Saddle taps are permitted in existing duct.
 - a. Velocity 1000 fpm or Lower: 90-degree tap.
 - b. Velocity 1000 to 1500 fpm: Conical tap.
 - c. Velocity 1500 fpm or Higher: 45-degree lateral.

END OF SECTION

SECTION 23 33 00
AIR DUCT ACCESSORIES

PART 1 GENERAL**1.01 RELATED DOCUMENTS**

- A. Drawings and general provisions of the Contract, including General and Supplementary Conditions and Division 01 Specification Sections, apply to this Section.

1.02 SUMMARY

- A. Section Includes:
1. Manual volume dampers.
 2. Flange connectors.
 3. Flexible connectors.
 4. Flexible ducts.
 5. Duct accessory hardware.
- B. Related Requirements:
1. Section 283111 "Digital, Addressable Fire-Alarm System" for duct-mounted fire and smoke detectors.
 2. Section 283112 "Zoned (DC-Loop) Fire-Alarm System" for duct-mounted fire and smoke detectors.

1.03 ACTION SUBMITTALS

- A. Product Data: For each type of product.
1. For duct silencers, include pressure drop and dynamic insertion loss data. Include breakout noise calculations for high transmission loss casings.
- B. Shop Drawings: For duct accessories. Include plans, elevations, sections, details and attachments to other work.
1. Detail duct accessories fabrication and installation in ducts and other construction. Include dimensions, weights, loads, and required clearances; and method of field assembly into duct systems and other construction. Include the following:
 - a. Special fittings.
 - b. Manual volume damper installations.
 - c. Wiring Diagrams: For power, signal, and control wiring.

1.04 INFORMATIONAL SUBMITTALS

- A. Coordination Drawings: Reflected ceiling plans, drawn to scale, on which ceiling-mounted access panels and access doors required for access to duct accessories are shown and coordinated with each other, using input from Installers of the items involved.
- B. Source quality-control reports.

1.05 CLOSEOUT SUBMITTALS

- A. Operation and Maintenance Data: For air duct accessories to include in operation and maintenance manuals.

PART 2 PRODUCTS**2.01 ASSEMBLY DESCRIPTION**

- A. Comply with NFPA 90A, "Installation of Air Conditioning and Ventilating Systems," and with NFPA 90B, "Installation of Warm Air Heating and Air Conditioning Systems."
- B. Comply with SMACNA's "HVAC Duct Construction Standards - Metal and Flexible" for acceptable materials, material thicknesses, and duct construction methods unless otherwise indicated. Sheet metal materials shall be free of pitting, seam marks, roller marks, stains, discolorations, and other imperfections.

2.02 MATERIALS

- A. Galvanized Sheet Steel: Comply with ASTM A 653/A 653M.

1. Galvanized Coating Designation: G60.
 2. Exposed-Surface Finish: Mill phosphatized.
- B. Stainless-Steel Sheets: Comply with ASTM A 480/A 480M, Type 304, and having a No. 2 finish for concealed ducts and exposed ducts.
- C. Aluminum Sheets: Comply with ASTM B 209, Alloy 3003, Temper H14; with mill finish for concealed ducts and standard, 1-side bright finish for exposed ducts.
- D. Extruded Aluminum: Comply with ASTM B 221, Alloy 6063, Temper T6.
- E. Reinforcement Shapes and Plates: Galvanized-steel reinforcement where installed on galvanized sheet metal ducts; compatible materials for aluminum and stainless-steel ducts.
- F. Tie Rods: Galvanized steel, 1/4-inch minimum diameter for lengths 36 inches or less; 3/8-inch minimum diameter for lengths longer than 36 inches.

2.03 MANUAL VOLUME DAMPERS

- A. Standard, Aluminum, Manual Volume Dampers:
1. Manufacturers: Subject to compliance with requirements, available manufacturers offering products that may be incorporated into the Work include, but are not limited to, the following:
 - a. Air Balance Inc.; a division of Mestek, Inc.
 - b. American Warming and Ventilating; a division of Mestek, Inc.
 - c. McGill AirFlow LLC.
 - d. Nailor Industries Inc.
 - e. Pottorff.
 - f. Ruskin Company.
 - g. Trox USA Inc.
 - h. Vent Products Company, Inc.
 2. Standard leakage rating, with linkage outside airstream.
 3. Suitable for horizontal or vertical applications.
 4. Frames: Hat-shaped, 0.10-inch- thick, aluminum sheet channels; frames with flanges for attaching to walls and flangeless frames for installing in ducts.
 5. Blades:
 - a. Multiple or single blade.
 - b. Parallel- or opposed-blade design.
 - c. Stiffen damper blades for stability.
 - d. Roll-Formed Aluminum Blades: 0.10-inch- thick aluminum sheet.
 - e. Extruded-Aluminum Blades: 0.050-inch- thick extruded aluminum.
 6. Blade Axles: Galvanized steel.
 7. Bearings:
 - a. Dampers in ducts with pressure classes of 3-inch wg or less shall have axles full length of damper blades and bearings at both ends of operating shaft.
 8. Tie Bars and Brackets: Aluminum.
- B. Jackshaft:
1. Size: 0.5-inch diameter.
 2. Material: Galvanized-steel pipe rotating within pipe-bearing assembly mounted on supports at each mullion and at each end of multiple-damper assemblies.
 3. Length and Number of Mountings: As required to connect linkage of each damper in multiple-damper assembly.
- C. Damper Hardware:
1. Zinc-plated, die-cast core with dial and handle made of 3/32-inch- thick zinc-plated steel, and a 3/4-inch hexagon locking nut.
 2. Include center hole to suit damper operating-rod size.
 3. Include elevated platform for insulated duct mounting.

2.04 FLANGE CONNECTORS

- A. Manufacturers: Subject to compliance with requirements, available manufacturers offering products that may be incorporated into the Work include, but are not limited to, the following:
 - 1. Ductmate Industries, Inc.
 - 2. Nexus PDQ; Division of Shilco Holdings Inc.
 - 3. Ward Industries, Inc.; a division of Hart & Cooley, Inc.
- B. Description: Add-on or roll-formed, factory-fabricated, slide-on transverse flange connectors, gaskets, and components.
- C. Material: Galvanized steel.
- D. Gage and Shape: Match connecting ductwork.

2.05 FLEXIBLE CONNECTORS

- A. Manufacturers: Subject to compliance with requirements, available manufacturers offering products that may be incorporated into the Work include, but are not limited to, the following:
 - 1. Ductmate Industries, Inc.
 - 2. Duro Dyne Inc.
 - 3. Elgen Manufacturing.
 - 4. Ventfabrics, Inc.
 - 5. Ward Industries, Inc.; a division of Hart & Cooley, Inc.
- B. Materials: Flame-retardant or noncombustible fabrics.
- C. Coatings and Adhesives: Comply with UL 181, Class 1.
- D. Metal-Edged Connectors: Factory fabricated with a fabric strip 3-1/2 inches wide attached to two strips of 2-3/4-inch- wide, 0.028-inch- thick, galvanized sheet steel or 0.032-inch- thick aluminum sheets. Provide metal compatible with connected ducts.
- E. Indoor System, Flexible Connector Fabric: Glass fabric double coated with neoprene.
 - 1. Minimum Weight: 26 oz./sq. yd..
 - 2. Tensile Strength: 480 lbf/inch in the warp and 360 lbf/inch in the filling.
 - 3. Service Temperature: Minus 40 to plus 200 deg F.
- F. Thrust Limits: Combination coil spring and elastomeric insert with spring and insert in compression, and with a load stop. Include rod and angle-iron brackets for attaching to fan discharge and duct.
 - 1. Frame: Steel, fabricated for connection to threaded rods and to allow for a maximum of 30 degrees of angular rod misalignment without binding or reducing isolation efficiency.
 - 2. Outdoor Spring Diameter: Not less than 80 percent of the compressed height of the spring at rated load.
 - 3. Minimum Additional Travel: 50 percent of the required deflection at rated load.
 - 4. Lateral Stiffness: More than 80 percent of rated vertical stiffness.
 - 5. Overload Capacity: Support 200 percent of rated load, fully compressed, without deformation or failure.
 - 6. Elastomeric Element: Molded, oil-resistant rubber or neoprene.
 - 7. Coil Spring: Factory set and field adjustable for a maximum of 1/4-inch movement at start and stop.

2.06 FLEXIBLE DUCTS

- A. Manufacturers: Subject to compliance with requirements, available manufacturers offering products that may be incorporated into the Work include, but are not limited to, the following:
 - 1. Flexmaster U.S.A., Inc.
 - 2. McGill AirFlow LLC.
 - 3. Ward Industries, Inc.; a division of Hart & Cooley, Inc.
- B. Insulated, Flexible Duct: UL 181, Class 1, 2-ply vinyl film supported by helically wound, spring-steel wire; fibrous-glass insulation; aluminized vapor-barrier film.

1. Pressure Rating: 10-inch wg positive and 1.0-inch wg negative.
 2. Maximum Air Velocity: 4000 fpm.
 3. Temperature Range: Minus 10 to plus 160 deg F.
 4. Insulation R-value: Comply with ASHRAE/IESNA 90.1.
- C. Flexible Duct Connectors:
1. Clamps: Stainless-steel band with cadmium-plated hex screw to tighten band with a worm-gear action or Nylon strap in sizes 3 through 18 inches, to suit duct size.
 2. Non-Clamp Connectors: Adhesive plus sheet metal screws.

2.07 DUCT ACCESSORY HARDWARE

- A. Instrument Test Holes: Cast iron or cast aluminum to suit duct material, including screw cap and gasket. Size to allow insertion of pitot tube and other testing instruments and of length to suit duct-insulation thickness.
- B. Adhesives: High strength, quick setting, neoprene based, waterproof, and resistant to gasoline and grease.

PART 3 EXECUTION

3.01 INSTALLATION

- A. Install duct accessories according to applicable details in SMACNA's "HVAC Duct Construction Standards - Metal and Flexible" for metal ducts and in NAIMA AH116, "Fibrous Glass Duct Construction Standards," for fibrous-glass ducts.
- B. Install duct accessories of materials suited to duct materials; use galvanized-steel accessories in galvanized-steel and fibrous-glass ducts, stainless-steel accessories in stainless-steel ducts, and aluminum accessories in aluminum ducts.
- C. Install volume dampers at points on supply, return, and exhaust systems where branches extend from larger ducts. Where dampers are installed in ducts having duct liner, install dampers with hat channels of same depth as liner, and terminate liner with nosing at hat channel.
1. Install steel volume dampers in steel ducts.
 2. Install aluminum volume dampers in aluminum ducts.
- D. Set dampers to fully open position before testing, adjusting, and balancing.
- E. Connect diffusers to ducts directly or with maximum 60-inch lengths of flexible duct clamped or strapped in place.
- F. Connect flexible ducts to metal ducts with adhesive plus sheet metal screws.
- G. Install duct test holes where required for testing and balancing purposes.

END OF SECTION

SECTION 23 37 13
DIFFUSERS, REGISTERS, AND GRILLES**PART 1 GENERAL****1.01 RELATED DOCUMENTS**

- A. Drawings and general provisions of the Contract, including General and Supplementary Conditions and Division 01 Specification Sections, apply to this Section.

1.02 SUMMARY

- A. Section Includes:
1. Rectangular sidewall grilles
 2. Rectangular and square ceiling diffusers.
 3. Perforated diffusers.
 4. Louver face diffusers.
 5. Louvers.
- B. Related Sections:
1. Section 089116 "Operable Wall Louvers" and Section 089119 "Fixed Louvers" for fixed and adjustable louvers and wall vents, whether or not they are connected to ducts.
 2. Section 233300 "Air Duct Accessories" for fire and smoke dampers and volume-control dampers not integral to diffusers, registers, and grilles.

1.03 ACTION SUBMITTALS

- A. Product Data: For each type of product indicated, include the following:
1. Data Sheet: Indicate materials of construction, finish, and mounting details; and performance data including throw and drop, static-pressure drop, and noise ratings.
 2. Diffuser, Register, and Grille Schedule: Indicate drawing designation, room location, quantity, model number, size, and accessories furnished.

1.04 INFORMATIONAL SUBMITTALS

- A. Coordination Drawings: Reflected ceiling plans, drawn to scale, on which the following items are shown and coordinated with each other, using input from Installers of the items involved:
1. Ceiling suspension assembly members.
 2. Method of attaching hangers to building structure.
 3. Size and location of initial access modules for acoustical tile.
 4. Ceiling-mounted items including lighting fixtures, diffusers, grilles, speakers, sprinklers, access panels, and special moldings.
 5. Duct access panels.
- B. Source quality-control reports.

PART 2 - PRODUCTS

- 2.01 Basis-of-Design Product:** Subject to compliance with requirements, provide product indicated on drawings or equal.

2.02 Refer to drawings.**PART 3 - EXECUTION****3.01 EXAMINATION**

- A. Examine areas where diffusers, registers, and grilles are to be installed for compliance with requirements for installation tolerances and other conditions affecting performance of equipment.
- B. Proceed with installation only after unsatisfactory conditions have been corrected.

3.02 INSTALLATION

- A. Install diffusers, registers, and grilles level and plumb.

- B. Ceiling-Mounted Outlets and Inlets: Drawings indicate general arrangement of ducts, fittings, and accessories. Air outlet and inlet locations have been indicated to achieve design requirements for air volume, noise criteria, airflow pattern, throw, and pressure drop. Make final locations where indicated, as much as practical. For units installed in lay-in ceiling panels, locate units in the center of panel. Where architectural features or other items conflict with installation, notify Architect for a determination of final location.
- C. Install diffusers, registers, and grilles with airtight connections to ducts and to allow service and maintenance of dampers, air extractors, and fire dampers.
- D. Install louvers per manufacturer recommendations.

3.03 ADJUSTING

- A. After installation, adjust diffusers, registers, and grilles to air patterns indicated, or as directed, before starting air balancing.

END OF SECTION

SECTION 23 81 23
COMPUTER-ROOM AIR-CONDITIONERS

PART 1 GENERAL**1.01 RELATED DOCUMENTS**

- A. Drawings and general provisions of the Contract, including General and Supplementary Conditions and Division 01 Specification Sections, apply to this Section.

1.02 SUMMARY

- A. Section Includes:
 - 1. Floor-mounted computer-room air conditioners, 6 tons and larger.

1.03 PERFORMANCE REQUIREMENTS

- A. Seismic Performance: Computer-room air conditioners shall withstand the effects of earthquake motions determined according to ASCE/SEI 7.
 - 1. The term "withstand" means "the unit will remain in place without separation of any parts from the device when subjected to the seismic forces specified and the unit will be fully operational after the seismic event."

1.04 ACTION SUBMITTALS

- A. Product Data: For each type of product indicated. Include rated capacities, operating characteristics, electrical characteristics, and furnished specialties and accessories.
- B. Shop Drawings: For computer-room air conditioners. Include plans, elevations, sections, details, and attachments to other work.
 - 1. Detail equipment assemblies and indicate dimensions, weights, loads, required clearances, method of field assembly, components, and location and size of each field connection.
 - 2. Wiring Diagrams: For power, signal, and control wiring.

1.05 INFORMATIONAL SUBMITTALS

- A. Coordination Drawings: Plans, elevations, and other details, drawn to scale, using input from Installers of the items involved.
- B. Seismic Qualification Certificates: For computer-room air conditioners, accessories, and components, from manufacturer.
 - 1. Basis for Certification: Indicate whether withstand certification is based on actual test of assembled components or on calculation.
 - 2. Dimensioned Outline Drawings of Equipment Unit: Identify center of gravity and locate and describe mounting and anchorage provisions.
 - 3. Detailed description of equipment anchorage devices on which the certification is based and their installation requirements.
- C. Field quality-control reports.
- D. Warranty: Sample of special warranty.

1.06 CLOSEOUT SUBMITTALS

- A. Operation and Maintenance Data: For computer-room air conditioners to include in emergency, operation, and maintenance manuals.

1.07 QUALITY ASSURANCE

- A. Electrical Components, Devices, and Accessories: Listed and labeled as defined in NFPA 70, by a qualified testing agency, and marked for intended location and application.
- B. ASHRAE Compliance:

1. Fabricate and label refrigeration system to comply with ASHRAE 15, "Safety Standard for Refrigeration Systems."
- C. ASHRAE/IESNA Compliance: Applicable requirements in ASHRAE/IESNA 90.1.
- D. ASME Compliance: Fabricate and label water-cooled condenser shell to comply with ASME Boiler and Pressure Vessel Code: Section VIII, "Pressure Vessels," Division 1.
- E. CRAC manufacturer must provide AHRI certified performance data (per AHRI Datacom Cooling Certification Program at AHRI Standard 1360 & ASHRAE Standard 127-2007) at specific conditions.

1.08 COORDINATION

- A. Coordinate layout and installation of computer-room air conditioners and suspension system with other construction that penetrates ceilings or is supported by them, including light fixtures, HVAC equipment, fire-suppression system, and partition assemblies.
- B. Coordinate installation of computer-room air conditioners with computer-room access flooring Installer.
- C. Coordinate sizes and locations of concrete bases with actual equipment provided.
- D. Coordinate sizes and locations of roof curbs, equipment supports, and roof penetrations with actual equipment provided.

PART 2 PRODUCTS

2.01 FLOOR-MOUNTED UNITS 6 TONS AND LARGER

- A. Basis-of-Design Product: Subject to compliance with requirements, provide product indicated on Drawings or comparable product by one of the following:
 1. Liebert
 2. Stulz
 3. DataAire
- B. Description: Packaged, factory assembled, prewired, and pre-piped; consisting of cabinet, fans, filters, humidifier, and controls.
- C. Cabinet and Frame: Welded steel, braced for rigidity, and supporting compressors and other mechanical equipment and fittings.
 1. Doors and Access Panels: Galvanized steel with polyurethane gaskets, hinges, and concealed fastening devices.
 2. Insulation: Thermally and acoustically insulate cabinet interior with 0.5-inch- thick insulation.
 3. Finish of Interior Surfaces: Double wall construction. Surfaces in contact with the airstream shall comply with requirements in ASHRAE 62.1.
 4. Finish of Exterior Surfaces: Powder coated steel panels; color as selected from manufacturer's standard colors.
 5. Floor Stand: Welded tubular steel with adjustable legs and vibration isolation pads.
- D. Supply-Air Fan(s):
 1. Backward-curved centrifugal plug fans; statically and dynamically balanced.
 2. Drive: Direct drive with ECM motors with separate speed controllers for each fan.
- E. Refrigeration System:
 1. Compressors: Hermetic scroll; with oil strainer, internal motor overload protection, resilient suspension system, crankcase heater, manual-reset high-pressure switch, and pump-down low-pressure switch.
 2. Refrigeration Circuits: Two; each with hot-gas mufflers, thermal-expansion valve with external equalizer, liquid-line solenoid valve, liquid-line filter-dryer, sight glass with moisture indicator, service shutoff valves, charging valves, and charge of refrigerant.
 3. Refrigerant: R-407C or R-410A.
 4. Refrigerant Evaporator Coil: Alternate-row or split-face-circuit, direct-expansion coil of seamless copper tubes expanded into aluminum fins.

- a. Mount coil assembly over stainless-steel drain pan complying with ASHRAE 62.1 and having a condensate pump unit with integral float switch, pump-motor assembly, and condensate reservoir.
5. Remote Air-Cooled Refrigerant Condenser: Corrosion-resistant cabinet, copper-tube aluminum-fin coils arranged for two circuits, multiple direct-drive propeller fans with permanently lubricated ball bearings, and single-phase motors with internal overload protection and integral electric control panel and disconnect switch.
- F. Electric-Resistance Heating Coil: Enclosed finned-tube electric elements arranged for minimum of three stages, with thermal safety switches, manual-reset overload protection, and branch-circuit overcurrent protection.
- G. Extended-Surface, Disposable, Panel Filter: Pleated, lofted, nonwoven, reinforced cotton fabric; supported and bonded to welded-wire grid; enclosed in cardboard frame.
 1. Thickness: 4 inches.
 2. Merv (ASHRAE 52.2): 8.
- H. Electrode Steam Humidifier: Self-contained, microprocessor-controlled unit with disposable, polypropylene-plastic cylinders, and having field-adjustable steel electrodes and stainless-steel steam dispersion tube.
 1. Plumbing Components and Valve Bodies: Plastic, linked by flexible rubber hosing, with water fill with air gap and solenoid valve incorporating built-in strainer, pressure-reducing and flow-regulating orifice, and drain with integral air gap.
 2. Control: Fully modulating to provide gradual 0 to 100 percent capacity with field-adjustable maximum capacity; with high-water probe.
 3. Drain Cycle: Field-adjustable drain duration and drain interval.
- I. Integral Electrical Controls: Unit-mounted electrical enclosure with piano-hinged door, grounding lug, combination magnetic starters with overload relays, circuit breakers and cover interlock, and fusible control-circuit transformer.
- J. Disconnect Switch: Nonautomatic, molded-case circuit breaker with handle accessible when panel is closed and capable of preventing access until switched to off position.
- K. Electronic-Control System: Solid state, with start button, stop button, temporary loss of power indicator, manual-reset circuit breakers, temperature control, humidity control, and monitor panel.
 1. Monitor Panel: Backlighted, with no visible indicator lights until operating function is activated; indicators include cooling, humidification, loss of airflow, change filters, high temperature, low temperature, high humidity, low humidity, high head pressure (each compressor), and low suction pressure (each compressor).
 2. Temperature- and Humidity-Control Modules: Solid state, plug-in; with adjustable set point, push-to-test calibration check button, and built-in visual indicators to show mode of operation.
 3. Location: Behind hinged door in front of unit; isolated from conditioned airstream to allow service while system is operating.
- L. Microprocessor-Control System: Continuously monitors operation of process cooling system; continuously displays room temperature and room relative humidity; sounds alarm on system malfunction and simultaneously displays problem. If more than one malfunction occurs, system displays fault in sequence with room temperature and continues to display fault when malfunction is cleared until system is reset.
 1. Malfunctions:
 - a. Power loss.
 - b. Loss of airflow.
 - c. Clogged air filter.
 - d. High room temperature.
 - e. Low room temperature.
 - f. High humidity.

- g. Low humidity.
 - h. Smoke/fire.
 - i. Water under floor.
 - j. Supply fan overload.
 - k. Compressor No. 1 - Overload.
 - l. Compressor No. 1 - Low Pressure.
 - m. Compressor No. 1 - High Pressure.
 - n. Compressor No. 2 - Overload.
 - o. Compressor No. 2 - Low Pressure.
 - p. Compressor No. 2 - High Pressure.
2. Digital Display:
- a. Control power on.
 - b. Humidifying.
 - c. Dehumidifying.
 - d. Compressor No. 1 - Operating.
 - e. Compressor No. 2 - Operating.
 - f. Heat operating.
 - g. Economy cooling.
3. Push buttons shall stop and start process cooling system, silence audible alarm, test indicators, and display room's relative humidity.

PART 3 EXECUTION

3.01 EXAMINATION

- A. Examine substrates, areas, and conditions, with Installer present, for compliance with requirements for installation tolerances and other conditions affecting performance of the Work.
- B. Examine roughing-in for hydronic piping systems to verify actual locations of piping connections before equipment installation.
- C. Examine walls, floors, and roofs for suitable conditions where computer-room air conditioners will be installed.
- D. Proceed with installation only after unsatisfactory conditions have been corrected.

3.02 INSTALLATION

- A. Install computer-room air conditioners level and plumb, maintaining manufacturer's recommended clearances. Install according to ARI Guideline B.
- B. Computer-Room Air-Conditioner Mounting: Install using elastomeric mounts. Comply with requirements for vibration isolation devices specified in Section 230548 "Vibration and Seismic Controls for HVAC."
- C. Air-Cooled Refrigerant Condenser Mounting: Install using elastomeric mounts. Comply with requirements for vibration isolation devices specified in Section 230548 "Vibration and Seismic Controls for HVAC."

3.03 CONNECTIONS

- A. Piping installation requirements are specified in other heating, ventilating, and air-conditioning Sections. Drawings indicate general arrangement of piping, fittings, and specialties.
- B. Install piping adjacent to machine to allow service and maintenance.
- C. Water and Drainage Connections: Comply with applicable requirements in Section 221116 "Domestic Water Piping." Provide adequate connections for water-cooled units, condensate drain, and humidifier flushing system.
- D. Refrigerant Piping: Comply with applicable requirements in Section 232300 "Refrigerant Piping." Provide shutoff valves and piping.

3.04 FIELD QUALITY CONTROL

- A. Manufacturer's Field Service: Engage a factory-authorized service representative to inspect, test, and adjust components, assemblies, and equipment installations, including connections.
- B. Perform tests and inspections.
 - 1. Manufacturer's Field Service: Engage a factory-authorized service representative to inspect components, assemblies, and equipment installations, including connections, and to assist in testing.
- C. Tests and Inspections:
 - 1. Inspect for and remove shipping bolts, blocks, and tie-down straps.
 - 2. After installing computer-room air conditioners and after electrical circuitry has been energized, test for compliance with requirements.
 - 3. Operational Test: After electrical circuitry has been energized, start units to confirm proper motor rotation and unit operation.
 - 4. Test and adjust controls and safeties. Replace damaged and malfunctioning controls and equipment.
- D. Computer-room air conditioners will be considered defective if they do not pass tests and inspections.
- E. Prepare test and inspection reports.
- F. After startup service and performance test, change filters and flush humidifier.

3.05 ADJUSTING

- A. Adjust initial temperature and humidity set points.
- B. Set field-adjustable switches and circuit-breaker trip ranges as indicated.
- C. Occupancy Adjustments: When requested within **12** months of date of Substantial Completion, provide on-site assistance in adjusting system to suit actual occupied conditions.

3.06 DEMONSTRATION

- A. Train Owner's maintenance personnel to adjust, operate, and maintain computer-room air conditioners.

END OF SECTION

SECTION 23 81 26
SPLIT-SYSTEM AIR-CONDITIONERS

PART 1 GENERAL**1.01 RELATED DOCUMENTS**

- A. Drawings and general provisions of the Contract, including General and Supplementary Conditions and Division 01 Specification Sections, apply to this Section.

1.02 SUMMARY

- A. Section includes split-system air-conditioning and heat-pump units consisting of separate evaporator-fan and compressor-condenser components.

1.03 ACTION SUBMITTALS

- A. Product Data: For each type of product indicated. Include rated capacities, operating characteristics, and furnished specialties and accessories. Include performance data in terms of capacities, outlet velocities, static pressures, sound power characteristics, motor requirements, and electrical characteristics.
- B. Shop Drawings: Include plans, elevations, sections, details, and attachments to other work.
 - 1. Detail equipment assemblies and indicate dimensions, weights, loads, required clearances, method of field assembly, components, and location and size of each field connection.
 - 2. Wiring Diagrams: For power, signal, and control wiring.
- C. Samples for Initial Selection: For units with factory-applied color finishes.

1.04 INFORMATIONAL SUBMITTALS

- A. Field quality-control reports.
- B. Warranty: Sample of special warranty.

1.05 CLOSEOUT SUBMITTALS

- A. Operation and Maintenance Data: For split-system air-conditioning units to include in emergency, operation, and maintenance manuals.

1.06 MAINTENANCE MATERIAL SUBMITTALS

- A. Furnish extra materials that match products installed and that are packaged with protective covering for storage and identified with labels describing contents.
 - 1. Filters: One set(s) for each air-handling unit.
 - 2. Gaskets: One set(s) for each access door.
 - 3. Fan Belts: One set(s) for each air-handling unit fan.

1.07 QUALITY ASSURANCE

- A. Electrical Components, Devices, and Accessories: Listed and labeled as defined in NFPA 70, by a qualified testing agency, and marked for intended location and application.
- B. ASHRAE Compliance:
 - 1. Fabricate and label refrigeration system to comply with ASHRAE 15, "Safety Standard for Refrigeration Systems."
 - 2. ASHRAE Compliance: Applicable requirements in ASHRAE 62.1, Section 4 - "Outdoor Air Quality," Section 5 - "Systems and Equipment," Section 6 - "Procedures," and Section 7 - "Construction and System Start-up."
- C. ASHRAE/IESNA Compliance: Applicable requirements in ASHRAE/IESNA 90.1.

1.08 COORDINATION

- A. Coordinate sizes and locations of concrete bases with actual equipment provided. Cast anchor-bolt inserts into bases. Concrete, reinforcement, and formwork are specified in Section 033000 "Cast-in-Place Concrete."

- B. Coordinate sizes and locations of roof curbs, equipment supports, and roof penetrations with actual equipment provided.

1.09 WARRANTY

- A. Special Warranty: Manufacturer's standard form in which manufacturer agrees to repair or replace components of split-system air-conditioning units that fail in materials or workmanship within specified warranty period.
 - 1. Warranty Period:
 - a. For Compressor: Five year(s) from date of Substantial Completion.
 - b. For Parts: Five year(s) from date of Substantial Completion.
 - c. For Labor: Five year(s) from date of Substantial Completion.

PART 2 PRODUCTS

2.01 MANUFACTURERS

- A. Basis-of-Design Product: Subject to compliance with requirements, provide product indicated on Drawings or comparable product by one of the following:
 - 1. Trane; a business of American Standard companies.
 - 2. YORK; a Johnson Controls company.
 - 3. Daikin
 - 4. Carrier

2.02 INDOOR UNITS (5 TONS OR LESS)

- A. Vertical Evaporator-Fan Components:
 - 1. Chassis: Galvanized steel with flanged edges, removable panels for servicing, and insulation on back of panel.
 - 2. Insulation: Faced, glass-fiber duct liner.
 - 3. Refrigerant Coil: Copper tube, with mechanically bonded aluminum fins and thermal-expansion valve. Comply with ARI 206/110.
 - 4. Electric Coil: Helical, nickel-chrome, resistance-wire heating elements; with refractory ceramic support bushings, automatic-reset thermal cutout, built-in magnetic contactors, manual-reset thermal cutout, airflow proving device, and one-time fuses in terminal box for overcurrent protection.
 - 5. Fan: Forward-curved, double-width wheel of galvanized steel; directly connected to motor.
 - 6. Fan Motors:
 - a. Comply with NEMA designation, temperature rating, service factor, enclosure type, and efficiency requirements specified in Section 230513 "Common Motor Requirements for HVAC Equipment."
 - b. Multitapped, multispeed with internal thermal protection and permanent lubrication.
 - c. Wiring Terminations: Connect motor to chassis wiring with plug connection.
 - 7. Airstream Surfaces: Surfaces in contact with the airstream shall comply with requirements in ASHRAE 62.1.
 - 8. Filters: Permanent, cleanable.
 - 9. Condensate Drain Pans:
 - a. Fabricated with two percent slope in at least two planes to collect condensate from cooling coils (including coil piping connections, coil headers, and return bends) and humidifiers, and to direct water toward drain connection.
 - 1) Length: Extend drain pan downstream from leaving face to comply with ASHRAE 62.1.
 - 2) Depth: A minimum of 2 inches deep.
 - b. Single-wall, stainless-steel sheet.
 - c. Drain Connection: Located at lowest point of pan and sized to prevent overflow. Terminate with threaded nipple on one end of pan.
 - 1) Minimum Connection Size: NPS 1.
 - d. Pan-Top Surface Coating: Asphaltic waterproofing compound.

- e. Units with stacked coils shall have an intermediate drain pan to collect condensate from top coil.

2.03 OUTDOOR UNITS (5 TONS OR LESS)

- A. Air-Cooled, Compressor-Condenser Components:
 - 1. Casing: Steel, finished with baked enamel in color selected by Architect, with removable panels for access to controls, weep holes for water drainage, and mounting holes in base. Provide brass service valves, fittings, and gage ports on exterior of casing.
 - 2. Compressor: Hermetically sealed with crankcase heater and mounted on vibration isolation device. Compressor motor shall have thermal- and current-sensitive overload devices, start capacitor, relay, and contactor.
 - a. Compressor Type: Scroll.
 - b. Two-speed compressor motor with manual-reset high-pressure switch and automatic-reset low-pressure switch.
 - c. Refrigerant Charge: R-410A.
 - d. Refrigerant Coil: Copper tube, with mechanically bonded aluminum fins and liquid subcooler. Comply with ARI 206/110.
 - 3. Heat-Pump Components: Reversing valve and low-temperature-air cutoff thermostat.
 - 4. Fan: Aluminum-propeller type, directly connected to motor.
 - 5. Factory applied epoxy coated condenser coil
 - 6. Motor: Permanently lubricated, with integral thermal-overload protection.
 - 7. Low Ambient Kit: Permits operation down to 45 deg F.
 - 8. Mounting Base: Concrete pad

2.04 ACCESSORIES

- A. Thermostat: Low voltage with subbase to control compressor and evaporator fan.
- B. Automatic-reset timer to prevent rapid cycling of compressor.
- C. Refrigerant Line Kits: Soft-annealed copper suction and liquid lines factory cleaned, dried, pressurized, and sealed; factory-insulated suction line with flared fittings at both ends.
- D. Drain Hose: For condensate.

PART 3 EXECUTION

3.01 INSTALLATION

- A. Install units level and plumb.
- B. Install evaporator-fan components using manufacturer's standard mounting devices securely fastened to building structure.
- C. Equipment Mounting:
 - 1. Install ground-mounted, compressor-condenser components on cast-in-place concrete equipment base(s).
 - 2. Install ground-mounted, compressor-condenser components on concrete mounting base.
 - 3. Comply with requirements for vibration isolation and seismic control devices specified in Section 230548 "Vibration and Seismic Controls for HVAC."
- D. Install and connect pre-charged refrigerant tubing to component's quick-connect fittings. Install tubing to allow access to unit.

3.02 CONNECTIONS

- A. Piping installation requirements are specified in other Sections. Drawings indicate general arrangement of piping, fittings, and specialties.
- B. Where piping is installed adjacent to unit, allow space for service and maintenance of unit.
- C. Duct Connections: Duct installation requirements are specified in Section 233113 "Metal

Ducts." Drawings indicate the general arrangement of ducts. Connect supply and return ducts to split-system air-conditioning units with flexible duct connectors. Flexible duct connectors are specified in Section 233300 "Air Duct Accessories."

3.03 FIELD QUALITY CONTROL

- A. Manufacturer's Field Service: Engage a factory-authorized service representative to inspect, test, and adjust components, assemblies, and equipment installations, including connections.
- B. Perform tests and inspections.
 - 1. Manufacturer's Field Service: Engage a factory-authorized service representative to inspect components, assemblies, and equipment installations, including connections, and to assist in testing.
- C. Tests and Inspections:
 - 1. Leak Test: After installation, charge system and test for leaks. Repair leaks and retest until no leaks exist.
 - 2. Operational Test: After electrical circuitry has been energized, start units to confirm proper motor rotation and unit operation.
 - 3. Test and adjust controls and safeties. Replace damaged and malfunctioning controls and equipment.
- D. Remove and replace malfunctioning units and retest as specified above.
- E. Prepare test and inspection reports.

3.04 STARTUP SERVICE

- A. Engage a factory-authorized service representative to perform startup service.
 - 1. Complete installation and startup checks according to manufacturer's written instructions.

3.05 DEMONSTRATION

- A. Engage a factory-authorized service representative to train Owner's maintenance personnel to adjust, operate, and maintain units.

END OF SECTION

SECTION 260500 - COMMON WORK RESULTS FOR ELECTRICAL

PART 1 - GENERAL

1.1 IMPOSED REGULATIONS

- A. Applicable provisions of the State and Local Codes and of the following codes and standards in addition to those listed elsewhere in the specifications are hereby imposed on a general basis for electrical work: codes and standards listed on the electrical drawings.

1.2 SCOPE OF WORK

- A. Provide all labor, materials, equipment and supervision to construct complete and operable electrical systems as indicated on the drawings and specified herein. All materials and equipment used shall be new, undamaged and free from any defects.

1.3 RELATED DOCUMENTS AND OTHER INFORMATION

- A. The general provisions of the Contract, including General and Supplementary Conditions and General Requirements, apply to the portions of work specified in each and every Section of this Division, individually and collectively.

1.4 EXISTING SERVICES AND FACILITIES

- A. **Damage to Existing Services:** Existing services and facilities damaged by the Contractor through negligence or through use of faulty materials or workmanship shall be promptly repaired, replaced, or otherwise restored to previous conditions by the Contractor without additional cost to the Owner.
- B. **Interruption of Services:** Interruptions of services necessary for connection to or modification of existing systems or facilities shall occur only at prearranged times approved by the Owner. Interruptions shall only occur after the provision of all temporary work and the availability of adequate labor and materials will assure that the duration of the interruption will not exceed the time agreed upon.
- C. **Removed Materials:** Existing materials made unnecessary by the new installation shall be stored on site. They shall remain the property of the Owner and shall be stored at a location and in a manner as directed by the Owner. If classified by the Owner's authorized representative as unsuitable for further use, the material shall become the property of the Contractor and shall be removed from the site at no additional cost to the owner.

1.5 PRODUCT WARRANTIES

- A. Provide manufacturer's standard printed commitment in reference to a specific product and normal application, stating that certain acts of restitution will be performed for the Purchaser or Owner by the manufacturer, when and if the product fails within certain operational conditions and time limits. Where the warranty requirements of a specific specification section exceeds the manufacturer's standard warranty, the more stringent requirements will apply and modified manufacturer's warranty shall be provided. In no case shall the manufacturer's warranty be less than one (1) year.

1.6 PRODUCT SUBSTITUTIONS

- A. **General:** Materials specified by manufacturer's name shall be used unless prior approval of an alternate is given by addenda. Requests for substitutions must be received in the office of the Architect at least 10 days prior to opening of bids.

1.7 ELECTRICAL DRAWINGS

- A. Electrical contract drawings are diagrammatic and indicate the general arrangement of electrical equipment. Do not scale electrical plans. Obtain all dimensions from the Architect's dimensioned drawings and field measurements. The Contractor shall review Architectural plans for door swings and built-in equipment; conditions indicated on those plans shall govern for this work.
- B. Coordinate installation of electrical equipment with the structural and mechanical equipment and access thereto. Coordinate exterior electrical work with civil and landscaping work.
- C. Discrepancies shown on different drawings, between drawings and specifications or between documents and field conditions shall be installed to provide the better quality or greater quantity of work; or, comply with the more stringent requirement; either or both in accordance with the A/E's interpretation.

1.8 SYSTEMS REQUIRING ROUGH-IN

- A. Rough-in shall consist of all outlet boxes/raceway systems/supports and sleeves required for the installation of cables/devices by other Divisions and by the Owner. It shall be the responsibility of this Contractor to determine the requirements by reviewing the contract documents and meeting with the Superintendent of the trade involved and Owner's representative to review submittal data, shop drawings, etc.
- B. Sealing of all sleeves, to meet the fire rating of the assembly, whether active or not, is work of this Division.

1.9 SUBMITTALS

- A. Refer to section 260510

PART 2 - PRODUCTS

2.1 FIRESTOPPING:

- A. Refer to Division 07 sections for additional requirements.
- B. A firestop system shall be used to seal penetrations of electrical conduits and cables through fire-rated partitions per the NEC. The firestop system shall be qualified by formal performance testing in accordance with ASTM E-814, or UL 1479.
- C. The firestop system shall consist of a fire-rated caulk type substance and a high temperature fiber insulation. It shall be permanently flexible, waterproof, non-toxic, smoke and gas tight and have a high adhesion to all solids so damming is not required. Only metal conduit shall be used in conjunction with this system to penetrate fire rated partitions. Install in strict compliance with manufacturer's recommendations. 3M, Hilti, STI or equal

PART 3 - EXECUTION

3.1 PRODUCT INSTALLATION, GENERAL

- A. Except where more stringent requirements are indicated, comply with the product manufacturer's installation instructions and recommendations, including handling, anchorage, assembly, connections, cleaning and testing, charging, lubrication, startup, test operation and shut-down of operating equipment. Consult with manufacturer's technical experts, for specific

instructions on unique product conditions and unforeseen problems.

- B. Protection and Identification: Deliver products to project properly identified with names, models numbers, types, grades, compliance labels and similar information needed for distinct identifications; adequately packaged or protected to prevent deterioration during shipment, storage and handling. Store in a dry, well ventilated, indoor space, except where prepared and protected by the manufacturer specifically for exterior storage.
- C. Permits and Tests: Provide labor, material and equipment to perform all tests required by the governing agencies and submit a record of all tests to the Owner or his representative. Notify the Architect five days in advance of any testing.
- D. Install temporary protective covers over equipment enclosures, outlet boxes and similar items after interiors, conductors, devices, etc. are installed, to prevent the entry of construction debris and to protect the installation during finish work performed by others. Do not install device plates, equipment covers or trims until finish work is complete.
- E. Clean all equipment, inside and out, upon completion of the work. Scratched or marred surfaces shall be touched-up with touch-up paint furnished by the equipment manufacturer.
- F. Replace all equipment and materials that become damaged.
- G. No more than three phase conductors, each of opposite phases for a three phase WYE system, shall be combined in a single raceway unless written approval is granted by the engineer or noted otherwise on the construction documents. (For 120 volt and 277 volt receptacle and lighting circuits are no more than 3 circuits unless written approval is granted by the engineer or noted otherwise on the construction documents.)

3.2 LOW VOLTAGE CABLING SEPARATION FROM EMI SOURCES

- A. Comply with BICSI TDMM and TIA/EIA-569-A recommendations for separating unshielded copper voice and data communication cable from potential EMI sources, including electrical power lines and equipment.
- B. Separation between open communications cables or cables in nonmetallic raceways and unshielded power conductors and electrical equipment shall be as follows:
 - 1. Electrical Equipment Rating Less Than 2 kVA: A minimum of 5 inches
 - 2. Electrical Equipment Rating between 2 and 5 kVA: A minimum of 12 inches
 - 3. Electrical Equipment Rating More Than 5 kVA: A minimum of 24 inches
- C. Separation between communications cables in grounded metallic raceways and unshielded power lines or electrical equipment shall be as follows:
 - 1. Electrical Equipment Rating Less Than 2 kVA: A minimum of 2-1/2 inches
 - 2. Electrical Equipment Rating between 2 and 5 kVA: A minimum of 6 inches
 - 3. Electrical Equipment Rating More Than 5 kVA: A minimum of 12 inches
- D. Separation between communications cables in grounded metallic raceways and power lines and electrical equipment located in grounded metallic conduits or enclosures shall be as follows:
 - 1. Electrical Equipment Rating Less Than 2 kVA: No requirement.
 - 2. Electrical Equipment Rating between 2 and 5 kVA: A minimum of 3 inches
 - 3. Electrical Equipment Rating More Than 5 kVA: A minimum of 6 inches
- E. Separation between Cables and Electrical Motors and Transformers, 5 kVA or HP and Larger: A minimum of 48 inches

- F. Separation between Cables and light fixtures: A minimum of 5 inches

3.3 EQUIPMENT PROTECTION

- A. Equipment and materials shall be protected during shipment and storage against physical damage, vermin, dirt, corrosive substances, fumes, moisture, cold and rain.
- B. Store equipment indoors in clean dry space with uniform temperature to prevent condensation. Equipment shall include but not be limited to switchgear, switchboards, panelboards, transformers, motor control centers, motor controllers, uninterruptible power systems, enclosures, controllers, circuit protective devices, cables, wire, light fixtures, electronic equipment, and accessories.
- C. During installation, equipment shall be protected against entry of foreign matter; and be vacuum-cleaned both inside and outside before testing and operating. Compressed air shall not be used to clean equipment. Remove loose packing and flammable materials from inside equipment.
- D. Damaged equipment shall be, as determined by the Engineer, placed in first class operating condition or be returned to the source of supply for repair or replacement.
- E. Painted surfaces shall be protected with factory installed removable heavy kraft paper, sheet vinyl or equal.
- F. Damaged paint on equipment and materials shall be refinished with the same quality of paint and workmanship as used by the manufacturer so repaired areas are not obvious.

3.4 ELECTRICAL WORK:

- A. Electrical work shall be accomplished with all affected circuits or equipment de-energized. When an electrical outage cannot be accomplished in this manner for the required work, the following requirements are mandatory:
 - 1. Electricians must use full protective equipment (i.e., certified and tested insulating material to cover exposed energized electrical components, certified and tested insulated tools, etc.) while working on energized systems in accordance with NFPA 70E.
 - 2. Electricians must wear personal protective equipment while working on energized systems in accordance with NFPA 70E.
 - 3. Before initiating any work, a job specific work plan must be developed by the contractor with a peer review conducted and documented by the Contractor. The work plan must include procedures to be used on and near the live electrical equipment, barriers to be installed, safety equipment to be used and exit pathways. This plan is subject to review and comment by the owner.
- B. Nothing in the above shall impose any duty on the Architects and Architect's consultants, nor relieve the General Contractor and its subcontractors of its obligations, duties and responsibilities including but not limited to, construction means, methods, sequence, techniques or procedures necessary for performing, superintending and coordinating the Electrical Work in accordance with the Contract Documents and any health or safety precautions required by any regulatory agencies.

END OF SECTION 260500

SECTION 260501 - ELECTRICAL DEMOLITION

PART 1 - GENERAL

1.1 Not Used

PART 2 - PRODUCTS

2.1 Not Used

PART 3 - EXECUTION

3.1 EXAMINATION

- A. Field verify measurements and circuiting arrangements are as shown on Drawings.
- B. Verify that abandoned wiring and equipment serve only abandoned facilities.
- C. Demolition drawings are based on casual field observation.
- D. Report discrepancies to Engineer before disturbing existing installation.
- E. Beginning of demolition means installer accepts existing conditions.

3.2 PREPARATION

- A. Disconnect electrical systems in walls, floors, and ceilings to be removed.
- B. Provide temporary wiring and connections to maintain existing systems in service during construction.
- C. When work must be performed on energized equipment or circuits, use personnel experienced in such operations, submit verification of compliance with the contractor's safety procedures to the Architect, and notify the Owner in writing a minimum of 24 hours prior to work.
- D. Existing Fire Alarm System: Maintain existing system in service until new system is installed and tested. Disable system only to make switchovers and connections. Minimize outage duration. Notify owner and AHJ before partially or completely disabling system.
- E. The existing television, telephone, computer data, intrusion detection and intercom system shall remain operable during construction. Plan and execute the work accordingly. Provide temporary wiring and facilities as may be required.

3.3 DEMOLITION AND EXTENSION OF EXISTING ELECTRICAL WORK

- A. Maintain electrical service to areas outside of the construction area.
- B. Remove, relocate, and extend existing installations to accommodate new construction.
- C. Remove abandoned wiring to source of supply.
- D. Remove exposed abandoned conduit, including abandoned conduit above accessible ceiling finishes. Cut conduit flush with walls and floors, and patch surfaces.

- E. Disconnect abandoned outlets and remove devices. Remove abandoned outlets if conduit servicing them is abandoned and removed. Provide blank cover for abandoned outlets that are not removed.
- F. Disconnect and remove abandoned panelboards and distribution equipment.
- G. Disconnect and remove electrical devices and equipment serving utilization equipment that has been removed.
- H. Disconnect and remove abandoned luminaries. Remove brackets, stems, hangers, and other accessories.
- I. Repair adjacent construction and finishes damaged during demolition and extension work.
- J. Maintain access to existing electrical installations that remain active. Modify installation or provide access panel as appropriate.
- K. Extend existing installations using materials and methods compatible with existing electrical installations, or as specified.
- L. All demolished ballasts and lamps shall be recycled.
- M. Remove all abandoned conductors and cables within the construction area.
- N. Support all existing communication cables within the construction area.
- O. Provide fire stopping for all existing communication conduit fire rated wall penetrations within the construction area.

3.4 CONSTRUCTION PHASING

- A. Plan and execute the work in accordance with the construction phasing indicated on the Architectural plans. Test and certify all systems, by phase of construction, so that "partial occupancy" can be obtained.

3.5 REUSE OF EXISTING MATERIALS

- A. Where new devices are to replace existing, it shall be permissible to reuse existing outlet boxes and branch circuit conduits. It shall be the responsibility of the Contractor to ensure that existing outlet boxes and conduits that are reused comply with requirements for new.
- B. The reuse of conduits (not remaining in place), conductors, and devices is not permitted.

3.6 CUTTING AND PATCHING

- A. Structural Limitations: Do not cut structural framing, walls, floors, decks, and other members intended to withstand stress, except with the Engineer's written authorization. Authorization will be granted only when there is no other reasonable method for completing the electrical work, and where the proposed cutting clearly does not materially weaken the structure.
- B. Cutting Concrete: Where authorized, cut openings through concrete (for conduit penetrations and similar services) by core drilling or sawing. Do not cut by hammer-driven chisel or drill. Prior to cutting of existing concrete walls, floors, or ceilings x-ray existing concrete to locate existing hidden utilities.

- C. Other Work: Do not endanger or damage other work through the procedures and process of cutting to accommodate electrical work. Review the proposed cutting with the Installer of the work to be cut, and comply with his recommendations to minimize damage. Where necessary, engage the original Installer or other specialists to execute the cutting in the recommended manner.
- D. Patching: Where patching is required to restore other work, because of cutting or other damage inflicted during the installation of electrical work, execute the patching in the manner recommended by the original Installer. Restore the other work in every respect, including the elimination of visual defects in exposed finished, as judged by the Engineer. Engage the original Installer to complete patching of various categories of work including: concrete and masonry finishing, waterproofing and roofing, exposed wall finishes, etc.

3.7 CLEANING AND REPAIR

- A. Clean and repair existing materials and equipment that remain or that are to be reused.
- B. Panelboards: Clean exposed surfaces and check tightness of electrical connections. Replace damaged circuit breakers and provide closure plates for vacant positions.

3.8 LABELING

- A. Provide typed circuit directory showing revised circuiting arrangement.
- B. Provide and install a new engraved nameplate for all electrical panels that have been modified during construction. Refer to the panelboard specification section for labeling requirements.

END OF SECTION 260501

SECTION 260510 – ELECTRICAL SUBMITTALS

PART 1 - GENERAL

1.1 RELATED REQUIREMENTS

- A. Comply with the applicable requirements of the Division 1 specifications (013300) and the requirements of this Division of the specifications.

1.2 SUBMITTALS

- A. Submit for review by the Engineer Architect a schedule with engineering data of materials and equipment to be incorporated in the work. Submittals shall be supported by descriptive materials, i.e., catalog sheets, product data sheets, diagrams, performance curves and charts published by the manufacturer, warranties, etc., to show conformance to Specifications and Plan requirements; model numbers alone shall not be acceptable. Data submitted for review shall contain all information to indicate compliance with Contract Documents. Complete electrical characteristics shall be provided for all equipment. Submittals for lighting fixtures shall include Photometric Data. The Engineer reserves the right to require samples of any equipment to be submitted for review.
- B. The purpose of shop drawing review is to demonstrate to the Architect that the Contractor understands the design concept. The Architect's review of such drawings, schedules, or cuts shall not relieve the Contractor from responsibility for deviations from the drawings or specifications unless he has, in writing, called the Architect's attention to such deviation at the time of submission, and received written permission from the Architect for such deviations.
- C. Where cut sheets include an entire product family, mark all specific items to be utilized for this project on equipment cut sheets. Generic cut sheets with no indication of which items on the cut sheet shall be used will be rejected.
- D. Response to Submittals: Shop drawings shall be returned by the Electrical Engineer with the following classifications:
 - 1. "No Exceptions Taken": No corrections, no marks. Contractor shall submit copies for distribution
 - 2. "Make Corrections Noted": A few minor corrections. Items may be ordered as marked up without further resubmission. Submit copies for distribution.
 - 3. "Amend and Resubmit": Minor corrections. Item may be ordered at the Contractor's risk. Contractor shall resubmit drawings with corrections noted.
 - 4. "Rejected - Resubmit": Major corrections or not in accordance with the contract documents. No items shall be ordered. Contractor shall correct and resubmit drawings.
- E. Prior Approvals and Shop Drawings must be hand delivered, received by mail, or email.
- F. Equipment and materials requiring submittals:
 - 1. Section 260500 – Common Work Results for Electrical
 - a. Product Warranties
 - b. Firestopping Materials
 - c. Firestopping Installation Drawings for each conduit penetration, cable in metal sleeve penetration and blank metal sleeve penetration for each type of wall/floor

construction encountered.

2. Section 260511 – Electrical Work Closeout
 - a. Record Drawings
 - b. Record Manuals
 - c. Close out submittals
 - d. Training verification
3. Section 260512 – Electrical Coordination
 - a. Coordination Affidavit
 - b. Electrical Coordination Drawings
 - c. Electrical schedule Gantt Chart
4. Section 260519 – Low-Voltage Electrical Conductors and Cables
 - a. Splice Kits
 - b. Waterproof Wire Connectors
 - c. Wire
 - d. Field Quality Control Test Reports
5. Section 260526 – Grounding and Bonding for Electrical Systems
 - a. Grounding Connections
 - b. Ground Wire
 - c. Field Quality Control Test Reports
 - d. Bonding Bushings
 - e. Bonding Jumper Braid
 - f. Ground bus bars
6. Section 260529 – Hangers and Supports for Electrical Systems
 - a. Product Data
7. Section 260536 – Cable Trays for Electrical Systems
 - a. Product Data
 - b. Layout Drawings in 1/8" = 1' scale minimum
 - c. Connectors
 - d. Bracing
 - e. Ground Clamps
 - f. Accessories
8. Section 260533 – Raceway and Boxes for Electrical Systems
 - a. Raceway
 - b. Boxes
 - c. Enclosure ratings
 - d. Dimension data
 - e. Floor Boxes
 - f. Corrosion Protection
9. Section 260548 – Vibration and Seismic Controls for Electrical Systems
 - a. Submit seismic force level (Fp) calculations from applicable building code.
 - b. Submit pre-approved restraint selections and installation details
 - c. Restraint selection and installation details shall be sealed by a professionally licensed engineer experienced in seismic restraint design.
 - d. Submit manufacturer's product data on strut channels including, but not limited to, types, materials, finishes, gauge thickness, and hole patterns. For each different strut cross-section, submit cross sectional properties including Section Modulus (Sx) and Moment of Inertia (Ix).

- e. Field reports
10. Section 260553 – Identification for Electrical Systems
 - a. Product data for all labeling products
 11. Section 262400 – Panelboards
 - a. Product data
 - b. Enclosures
 - c. Dimensional Data
 - d. Circuit Directory
 - e. Circuit Breaker trip curves
 - f. Locks
 - g. Shunt-Trip Breakers
 - h. Busing Diagrams
 - i. Ground-Fault Protection
 - j. Schematic Wiring Diagram
 - k. Layout Drawings and elevations
 - l. Short Circuit Current Rating
 - m. Device nameplate data.
 12. Section 262726 – Wiring Devices
 - a. Product data
 - b. Device Plates
 - c. Weatherproof Covers
 - d. Special Purpose Receptacles
 - e. Dimmer Switches
 - f. Occupancy Sensors
 - g. Occupancy Sensor Wiring Diagrams
 - h. Occupancy Sensor Layout Drawings showing location and orientation of each sensor.
 - i. Device and device plate colors
 13. Section 262816 – Enclosed Switches and Circuit Breakers
 - a. Product data
 - b. Enclosures
 - c. Dimensional Data
 - d. Control Wiring Diagrams
 - e. Accessories
 - f. Short Circuit Current Rating
 - g. Test reports
 - h. Indicate on the submittal the name of the load served by each device submitted.
 14. Section 264300 – Surge Protective Devices
 - a. Unit dimensions
 - b. Installation instructions
 - c. Product data
 - d. Warranty statement
 - e. Current Ratings
 - f. Clamping Voltages
 - g. Response Time
 - h. Enclosure
 15. Section 265100 – Interior Lighting
 - a. Lighting Fixtures

- b. Ballasts
 - c. Lamps
 - d. Emergency Ballasts
 - e. Emergency transfer units
 - f. Color Samples
16. Section 265600 – Exterior Lighting
- a. Lighting Fixtures
 - b. Ballasts
 - c. Lamps
 - d. Emergency Ballasts
 - e. Poles and Accessories
 - f. Color Samples
17. Section 271101 – Equipment Racks
- a. Product Data
 - b. Seismic Compliance Information
18. Section 271300 – Communication Backbone Cabling
- a. Cable
19. Section 283100 – Fire Detection and Alarm
- a. Surge Protection
 - b. Battery calculations.
 - c. Voltage drop calculations
 - d. Installer's qualifications.
 - e. Conduit fill calculations.
 - f. Manufacturer's detailed data sheet for each control unit, initiating device, and notification appliance.
 - g. Device layout drawings with proposed conduit routing. Drawings must be prepared using AutoCAD Release 2017 or newer.
 - h. System riser diagram.
 - i. List of all devices on each signaling line circuit, with spare capacity indicated.
 - j. Clear and concise description of operation, with input/output matrix similar to that shown in NFPA 72
 - k. Warranty
 - l. Include voice/alarm signaling-service equipment rack or console layout, grounding schematic, amplifier power calculation, and single-line connection diagram.
 - m. Verify that each duct detector is listed for complete range of air velocity, temperature, and humidity possible when air-handling system is operating.
 - n. Submission to Authority Having Jurisdiction: In addition to routine submission of the above material, make an identical submission to the authority having jurisdiction. Include copies of shop drawings as required to depict component locations to facilitate review. Upon receipt of comments from the Authority, make resubmissions if required to make clarifications or revisions to obtain approval.
 - o. Inspection and Test Reports:
 - 1) Submit inspection and test plan prior to closeout demonstration
 - 2) Submit documentation of satisfactory inspections and tests.
 - 3) Submit NFPA 72 "Inspection and Test Form," filled out.

PART 2 - PRODUCTS

2.1 Not Used.

PART 3 - EXECUTION

3.1 MANUFACTURER'S DATA

- A. Include the manufacturer's comprehensive product data sheet and installation instructions. Where operating ranges are shown, mark data to show portion of range required for project application. Where pre-printed data sheet covers more than one distinct product-size, type, material, trim, accessory group or other variations, delete or mark-out portions of the pre-printed data which are not applicable.

3.2 EQUIPMENT LIST

- A. Where more than one type of a product is being used (i.e. starters, disconnects, breakers, etc.) provide a list with each submittal correlating the type and size of product to the load served.

3.3 TEST REPORTS

- A. Submit test reports which have been signed and dated by the firm performing the tests, and prepare in the manner specified in the standard or regulation governing the tests procedure as indicated.

END OF SECTION 260510

SECTION 260511 - ELECTRICAL WORK CLOSEOUT

PART 1 - GENERAL

1.1 SUBMITTALS

- A. Refer to section 260510.

1.2 RELATED SECTIONS

- A. Refer to section 017839 for additional requirements.

PART 2 - PRODUCTS

2.1 RECORD DRAWINGS

- A. Except where otherwise indicated, electrical drawings prepared by Engineer are diagrammatic in nature and may not show locations accurately for various components of electrical system. Shop drawings, including coordination drawings, prepared by the Contractor show portions of work more accurately to scale and location, and in greater detail. It is recognized that actual layout of installed work may vary substantially from both Contractor drawings and shop drawings.
- B. The electrical superintendent shall maintain a white set of contract documents and shop drawings in clean, undamaged condition, for mark-up of actual installations which vary substantially from the work as shown. PDF or digital mark-ups is acceptable alternates Mark-up whatever drawings are most capable of showing installed conditions accurately. However, where shop drawings are marked, record a reference note on appropriate contract drawings. Mark with erasable pencil, and use multiple colors to aid in the distinction between work of separate electrical systems. These documents shall be used for no other purpose. In general, record every substantive installation of electrical work which previously is either not shown or shown inaccurately, but in any case record the following:
 - 1. Post all addenda prior to beginning work.
 - 2. Underground feeder conduits, both interior and exterior, drawn to scale and fully dimensioned.
 - 3. Work concealed behind or within other work, in a non-accessible arrangement.
 - 4. Mains and branches of wiring systems, with panelboards and control devices located and numbered, with concealed splices located, and with devices requiring maintenance located.
 - 5. Scope of each change order (C.O.), noting C.O. number.
- C. Upon each visit by the Architect/Engineer, the Contractor shall demonstrate that the record documents are being kept current, as specified hereinbefore.

2.2 RECORD MANUALS

- A. Record manuals shall include the following:
 - 1. Manufacturer's operation and maintenance manuals for:
 - a. Light Fixtures
 - b. Panelboards and Circuit Breakers
 - c. Surge Protection Devices
 - d. Fire Alarm System
 - e. Motor Starters
 - f. UPS systems
 - g. Lighting Control Systems

2. Shop drawings, revised to reflect all review comments, supplemented with the installation instructions shipped with equipment.
 3. One copy of all panelboard directories.
 4. All field test Reports
 5. Electrical Contractor's Warranty
 6. Fire alarm set of floor plans showing actual installed locations of components, conduit, and zones.
 7. Fire Alarm "As programmed" operating sequences, including control events by device, updated input/output chart, and voice messages by event.
- B. Submit record manuals in quantities and in the format prescribed in the Division 1 specifications.
- C. Submit copies of all Maintenance contracts including:
1. Fire Alarm Systems.
 2. UPS systems

2.3 CLOSEOUT SUBMITTALS

- A. Software and Firmware Operational Documentation:
1. Software operating and upgrade manuals.
 2. Program Software Backup: On USB drive, complete with data files.
 3. Device address list.
 4. Printout of software application and graphic screens.

PART 3 - EXECUTION

3.1 SITE VISITS

- A. At all construction observations by the Architect/Engineer, the Contractor shall demonstrate to the Architect/ Engineer that all work is complete in accordance with the contract documents and that all systems have been tested and are fully operational. The Contractor shall furnish the personnel, tools and equipment required to inspect and test all systems.

3.2 TRAINING

- A. Train Owner's personnel on the operation and maintenance of the following systems:
1. Fire Alarm System - 2 hours
 2. Lighting Control Systems – 4 hours
 3. UPS system - 4 hours
- B. Training shall not be conducted until system has been tested by the Contractor and is 100% operational. Refer to the individual specification sections for additional requirements.

END OF SECTION 260511

SECTION 260512 - ELECTRICAL COORDINATION

PART 1 - GENERAL

1.1 SUBMITTALS

- A. Refer to section 260510.

PART 2 - PRODUCTS

2.1 ELECTRICAL WORK SCHEDULE

- A. After the award of contract, the Contractor shall prepare a detailed schedule (aka milestone chart) using "Microsoft Project" software or equivalent. The Contractor Project Schedule (CPS) shall indicate detailed activities for the projected life of the project. The CPS shall consist of detailed activities and their restraining relationships. It will also detail manpower usage throughout the project.
- B. Electrical Work Schedule: Provide a Gantt chart for review by the Engineer and Owner at least 10-days prior to beginning work. The chart shall have color-coding to distinguish between demolition and renovation tasks as well as any other specific tasks. The Gantt chart shall include the following items:
 - 1. Date of on-site arrival of electrical equipment and accessories required for system installation.
 - 2. Estimated dates and duration of all service outage times.
 - 3. Estimated start date and completion date for the demolition.
 - 4. Estimated dates and duration of required work access to areas that are not in the current phase of work.

2.2 ELECTRICAL COORDINATION DRAWINGS

- A. Electrical Rooms: Provide layouts of all electrical rooms using the dimensions of equipment actually furnished. Locate all ducts and piping entering or crossing these spaces.
- B. Feeders over 100 Amps : The routing of main feeders is not shown on the drawings. Actual routing shall be determined by the contractor in accordance with the specifications and shall be coordinated with work by other trades. For underground lines, show all utility crossings.
- C. Drawing Format: Drawings shall be prepared at a scale of no less than 1/16"=1'-0" for feeder routes and 1/4"=1'-0" for electrical rooms/equipment yards. Drawing shall be titled to define Project Name, Drawing subject and date prepared. Drawings are to be prepared in AutoCAD 2007 or compatible software.

2.3 EQUIPMENT REQUIRING ELECTRICAL SERVICE

- A. Provide electrical connections for all electrically driven equipment. Final connections are electrical work, except as otherwise noted. Obtain a copy of the shop drawings of equipment. Review shop drawings to verify electrical characteristics and to determine rough-in requirements, final connection requirements, location of disconnect switch, etc. Notify the General Contractor if the information received is ambiguous or incomplete. Keep a copy of these shop drawings at the project site throughout the course of construction.
- B. Equipment to be connected includes, but is not limited to the following:
 - 1. HVAC Equipment
 - 2. Fire Protection Equipment

3. Telephone/Computer Systems
 4. Fire Alarm System
 5. Motorized Projection Screens and Ceiling Projectors
 6. A/V systems
 7. Control Systems
- C. The design of circuits for electrically driven equipment is based on the product of one manufacturer and may not be representative of all acceptable manufacturers. If equipment furnished has differing characteristics, make necessary adjustments to circuit components at no additional cost to the Owner, subject to the approval of the Engineer.
- D. Provide motor starters and disconnects for all mechanical equipment unless provided by the mechanical contractor.

PART 3 - EXECUTION

3.1 COORDINATION OF MECHANICAL INSTALLATION:

- A. Attachment Number 1 shall be filled out and returned with shop drawing submittals. The intent of Attachment Number 1 is to ensure that the electrical requirements for equipment have been reviewed and coordinated by the Contractor. No electrical equipment shall be ordered, nor shall rough-in begin, before this coordination has taken place. This document shall be returned appropriately marked whether or not any changes are deemed to be necessary by the contractor.

ATTACHMENT NO. 1

SHOP DRAWING COORDINATION AFFIDAVIT

I, the undersigned, certify that I have reviewed the equipment shop drawings for electrically driven equipment and that the accompanying electrical shop drawings reflect the requirements of the actual equipment to be furnished for use on this project. The following deviations from design drawings were required to serve the furnished equipment:

| ITEM | CKT.DESIG. | | BKR.SIZE | | CONDUIT/WIRE | | DISC.SIZE | | STARTER | |
|------|------------|-----|----------|-----|--------------|-----|-----------|-----|---------|-----|
| | New | Old | New | Old | New | Old | New | Old | New | Old |

NOTE: If no deviations are required please indicate by circling the appropriate answer above your signature.

PROJECT: _____ DEVIATIONS: Yes / No

COMPANY: _____

TITLE: _____ SIGNATURE: _____

TELEPHONE: _____ DATE: _____

IT IS THE RESPONSIBILITY OF THE DIVISION 26 CONTRACTOR TO OBTAIN SHOP DRAWING INFORMATION FROM OTHER TRADES. FAILURE TO PERFORM THE WORK REQUIRED BY THIS AFFIDAVIT, PRIOR TO ORDERING MATERIALS OR ROUGHING-IN, MAY RESULT IN IMPROPER CONNECTIONS BEING PROVIDED. THE EXPENSE OF CORRECTIVE MEASURES, IF REQUIRED, SHALL BE BORNE BY THE CONTRACTOR.

NOTE:
PANELBOARD SHOP DRAWINGS WILL NOT BE REVIEWED UNTIL THE ELECTRICAL CONTRACTOR COMPLETES AND SUBMITS THIS AFFIDAVIT TO THE ELECTRICAL ENGINEER.

END OF SECTION 260512

SECTION 260519 – LOW-VOLTAGE ELECTRICAL CONDUCTORS AND CABLES

PART 1 - GENERAL

1.1 SUMMARY

- A. This section includes the requirements for the following:
 - 1. Wire and cable for 600 volts and less.
 - 2. Wiring connectors and connections.

1.2 SUBMITTALS

- A. Refer to section 260510.

1.3 QUALITY ASSURANCE

- A. Conform to requirements of NFPA 70.
- B. Furnish products listed and classified by Underwriters Laboratories Inc. as suitable for the purpose specified and indicated.

1.4 REFERENCE STANDARDS

- A. NECA 1 - Standard for Good Workmanship in Electrical Contracting; National Electrical Contractors Association; current edition.
- B. NETA STD ATS - Acceptance Testing Specifications for Electrical Power Distribution Equipment and Systems; International Electrical Testing Association; current edition.
- C. NFPA 70 - National Electrical Code; National Fire Protection Association, current edition.

PART 2 - PRODUCTS

2.1 WIRING REQUIREMENTS

- A. Concealed Dry Interior Locations: Use only THHN-2, THWN-2 or XHHW-2 wire in raceway.
- B. Exposed Dry Interior Locations: Use only THHN-2, THWN-2, or XHHW-2 in raceway.
- C. Above Accessible Ceilings: Use only THHN-2, THWN-2, or XHHW-2 in raceway.
- D. Wet or Damp Interior Locations: Use only THWN-2 or XHHW-2 in raceway.
- E. Exterior locations (above or below grade) THWN-2, XHHW-2 or USE in raceway.
- F. Use conductors not smaller than 12 AWG for power and lighting circuits.
- G. Use conductors not smaller than 14 AWG for control circuits.
- H. Metal Clad (MC) cable can be used for 20 Amp branch circuits, when installed in concealed indoor locations. and not used for home runs.

2.2 BUILDING WIRE

- A. Conductor: Copper.
- B. Insulation Voltage Rating: 600 volts.
- C. Temperature Rating: 90° C.

PART 3 - EXECUTION

3.1 INSTALLATION

- A. Pull all conductors into raceway at same time.
- B. Use suitable wire pulling lubricant for building wire 4 AWG and larger. Do not exceed manufacturers recommended maximum pulling tensions and sidewall pressure values.
- C. Use pulling means, including fish tape, cable, rope, and basket-weave wire/cable grips that will not damage cables or raceway.
- D. Neatly train and lace wiring inside boxes, equipment, and panelboards.
- E. Clean conductor surfaces before installing lugs and connectors.
- F. Make splices, taps, and terminations to carry full ampacity of conductors with no perceptible temperature rise.
- G. Use split bolt connectors or compression fittings for splices and taps on conductors 6 AWG and larger. Tape uninsulated conductors and connector with electrical tape to 150 percent of insulation rating of conductor.
- H. Use solderless pressure connectors with insulating covers for copper conductor splices and taps, 8 AWG and smaller.
- I. Use insulated spring wire connectors with plastic caps for copper conductor splices and taps, 10 AWG and smaller.
- J. Tighten electrical connectors and terminals according to manufacturer's published torque-tightening values or UL 486A and UL 486B.
- K. Identify and color code wire and cable under provisions of Section 26 05 53. Identify each conductor with its circuit number or other designation indicated.
- L. For each electrical connection/termination, provide a complete assembly of materials, including but not necessarily limited to, pressure connectors, terminals (lugs), electrical insulating tape, heat-shrinkable insulating tubing, cable ties, solderless wire nuts, and other materials necessary to complete splices and terminations. Torque all connections according to installation instructions.
- M. Motor connections shall be made with compression connectors forming a bolted in-line or stub-type connection.
- N. Splicing of feeder conductors shall not be acceptable, unless specifically indicated on the drawing. Where splicing of feeder conductors is indicated, splices shall be made using compression type butt splice.

- O. All splices made underground or in the pipe basements shall be rated suitable for water immersion.
- P. Support for Conductors in Vertical Conduit: Factory-fabricated assembly consisting of threaded body and insulating wedging plug or plugs for cables in riser conduits. Plugs shall have number, size, and shape of conductor gripping pieces as required to suit individual conductors or cables supported. Body shall be malleable iron.
- Q. All MC cable shall be installed perpendicular or parallel to building structure and supports at intervals of 5 feet or less.
- R. Cable ties shall not be used to support MC cables.

3.2 LABELING

- A. Color Coding
 - 1. Color shall be green for grounding conductors and green with yellow stripe for isolated grounding conductors.
 - 2. The color of the circuit conductors shall be as follows:

| | |
|-----------------------|-----------------|
| 120/208 volt, 3-phase | Phase A - Black |
| | Phase B -Red |
| | Phase C - Blue |
| | Neutral - White |

3.3 FIELD QUALITY CONTROL

- A. Inspect and test in accordance with NETA STD ATS, except Section 4.
- B. Perform inspections and tests listed in NETA STD ATS, Section 7.3.2.

END OF SECTION 260519

SECTION 260526 – GROUNDING AND BONDING FOR ELECTRICAL SYSTEMS

PART 1 - GENERAL

1.1 SUMMARY

- A. Grounding and bonding components.
- B. Provide all components necessary to complete the grounding system(s) consisting of:
 - 1. Existing and new metal underground water pipe.
 - 2. Metal frame of the building.
 - 3. Steel water storage tank and supports.
 - 4. Concrete-encased electrode.

1.2 SUBMITTALS

- A. Refer to section 260510.

1.3 QUALITY ASSURANCE

- A. Conform to requirements of NFPA 70.

1.4 REFERENCES

- A. NETA STD ATS - Acceptance Testing Specifications for Electrical Power Distribution Equipment and Systems; International Electrical Testing Association; current edition.
- B. NFPA 70 - National Electrical Code; National Fire Protection Association; current edition.
- C. NFPA 99 - Standard for Health Care Facilities; National Fire Protection Association; current edition.
- D. IEEE Standard 142 "Green Book" – Recommended Practices for Grounding of industrial and Commercial Power Systems; current edition.

1.5 PERFORMANCE REQUIREMENTS

- A. Maximum grounding system resistance: 15 ohms.
- B. Services at power company interface points shall comply with the power company ground resistance requirements.

PART 2 - PRODUCTS

2.1 ELECTRODES

- A. Sectionalized steel with copper-welded exterior, 3/4" dia. x 10'. One 10-foot section shall be required at each ground rod location, unless as otherwise directed in this specification.

2.2 CONDUCTORS

- A. Bonding Jumper Braid: Copper braided tape, sized for application.
- B. Electrical Grounding conductors: Unless otherwise indicated, provide bare or green insulated stranded copper electrical grounding conductors sized according to NEC or as shown or

specified. Provide green insulated for conductors sized No. 10 AWG and smaller.

2.3 GROUND CONNECTIONS

- A. Below Grade: Exothermic-welded type connectors.
- B. Above Grade:
 - 1. Bonding Jumpers: compression type connectors, using zinc-plated fasteners and external tooth lock washers.
 - 2. Ground Busbars: Two-hole compression type lugs using tin-plated copper or copper alloy bolts and nuts.
 - 3. Rack and Cabinet Ground Bars: one-hole compression-type lugs using zinc-plated or copper alloy fasteners.
- C. Install exothermic connectors and terminals as recommended by the connector and terminal manufacturer for intended applications.
- D. Bolted clamp will not be accepted between grounding rods and ground conductors.

2.4 EQUIPMENT RACK AND CABINET GROUND BARS

- A. Provide solid copper ground bars designed for mounting on the framework of open or cabinet-enclosed equipment racks with minimum dimensions of 3/8 inch x 3/4 inch unless noted otherwise.
- B. Busbar Connectors: Cast silicon bronze, solderless, mechanical connector; with a long barrel and two holes spaced on 5/8- or 1-inch (15.8- or 25.4-mm) centers for a two-bolt connection to the busbar.
- C. Telecommunications Enclosures and Equipment Racks: Bond metallic components of enclosures to the telecommunications bonding and grounding system. Install top-mounted rack grounding busbar unless the enclosure and rack are manufactured with the busbar. Bond the equipment grounding busbar to the TGB No. 2 AWG bonding conductors.
- D. Shielded Cable: Bond the shield of shielded cable to the TGB in communications rooms and spaces. Comply with TIA/EIA-568-B.1 and TIA/EIA-568-B.2 when grounding screened, balanced, twisted-pair cables.
- E. Rack- and Cabinet-Mounted Equipment: Bond powered equipment chassis to the cabinet or rack grounding bar. Power connection shall comply with NFPA 70; the equipment grounding conductor in the power cord of cord- and plug-connected equipment shall be considered as a supplement to bonding requirements in this Section.

2.5 GROUND TERMINAL BLOCKS

- A. At any equipment mounting location (e.g. backboards and hinged cover enclosures) where rack-type ground bars cannot be mounted, provide screw lug-type terminal blocks.

PART 3 - EXECUTION

3.1 EXAMINATION

- A. Verify existing conditions prior to beginning work.

3.2 ELECTRICAL AND COMMUNICATION ROOM GROUNDING

- A. Building Earth Ground Busbars: Provide ground busbar hardware at each electrical and communication room and connect to pigtail extensions of the building grounding ring.

3.3 CONDUCTIVE PIPING

- A. Bond all conductive piping systems (excluding fuel gas piping), interior and exterior, to the building to the grounding electrode system. Bonding connections shall be made as close as practical to the equipment ground bus.
- B. Install braided type bonding jumpers with ground clamps on water meter piping to electrically bypass meter where the main is metallic on both sides of the meter. Install clamp-on connectors only on thoroughly cleaned metal contact surfaces, to ensure electrical conductivity and circuit integrity.

3.4 CORROSION INHIBITORS

- A. When making ground and ground bonding connections, apply a corrosion inhibitor to all contact surfaces. Use corrosion inhibitor appropriate for protecting a connection between the metals used.
- B. Where concrete penetration is necessary, non-metallic conduit shall be cast flush with the points of concrete entrance and exit so as to provide an opening for the ground wire and the opening shall be sealed with a suitable compound after installation of the ground wire.

3.5 SECONDARY EQUIPMENT AND CIRCUITS

- A. Panelboards, Disconnects, Switchboards, and Motor Control Centers; Connect metallic conduits, which terminate without mechanical connection to the housing, by grounding bushings and grounding conductor to the equipment ground bus.
- B. Feeders and Branch Circuits: Install equipment grounding conductors with all feeders and power and lighting branch circuits, sized in accordance with Article 250 of NFPA 70.
- C. Boxes, Cabinets, Enclosures, and Panelboards:
 - 1. Bond the equipment grounding conductor to each pullbox, junction box, outlet box, device box, cabinets, and other enclosures through which the conductor passes (except for special grounding systems for intensive care units and other critical units shown).
 - 2. Provide lugs in each box and enclosure for equipment grounding conductor termination.
 - 3. Provide ground bars in panelboards, bolted to the housing, with sufficient lugs to terminate the equipment grounding conductors.
- D. Motors and Starters: Provide lugs in motor terminal box and starter housing or motor control center compartment to terminate equipment grounding conductors.
- E. Receptacles shall not be grounded through their mounting screws. Ground with a jumper from the receptacle green ground terminal to the device box ground screw and the branch circuit equipment grounding conductor.
- F. Fixed electrical appliances and equipment shall be provided with a ground lug for termination of the equipment grounding conductor.
- G. Metallic Conduit: Metallic conduits which terminate without mechanical connection to an electrical equipment housing by means of locknut and bushings or adapters, shall be provided

with grounding bushings. Connect bushings with a bare grounding conductor to the equipment ground bus.

3.6 INSTALLATION

- A. Install ground electrodes at locations indicated. Provide additional electrodes as required to achieve specified resistance to ground.
- B. Install nominal 10" diameter x 18" long fiberglass "water valve" type enclosure, with cover, over each ground rod. The top of ground rods shall be 12" below finished grade. The rod and exothermic connection to the grounding electrode conductor shall be accessible from within enclosure. Fill the lower 3" of enclosure with crushed rocks. Top of enclosure shall be flush with finished grade.
- C. Make rebar in concrete footing around the perimeter of the building electrically continuous such that the resulting installation consists of a concrete encased electrode per Article 250 of the NEC. Extend No. 1/0 THWN grounding electrode conductors from convenient points along the "ground ring" to the equipment ground system.
- D. If it is determined that the rebar cannot be made electrically continuous, install a No 1/0 bare copper conductor in the footing around the perimeter of the building.
- E. Provide grounding electrode conductor and connect to reinforcing steel in foundation footing.
- F. Bond together metal siding not attached to grounded structure; bond to ground.
- G. Bond together reinforcing steel and metal accessories in pool and fountain structures.

3.7 ACCESS FLOORS

- A. Install ground grid under communication access floors. Construct grid of 2AWG bare copper wire installed on 24 inch centers both ways. Bond each access floor pedestal to grid.
- B. Bond together each metallic raceway, pipe, duct and other metal object entering space under access floors; Bond to underfloor ground grid.
- C. Equipment Grounding Conductor: Provide separate, insulated conductor within each feeder and branch circuit raceway. Terminate each end on suitable lug, bus, or bushing.

3.8 FIELD QUALITY CONTROL

- A. Inspect and test in accordance with NETA STD ATS except Section 4.
- B. Perform inspections and tests listed in NETA STD ATS, Section 7.13.
- C. Upon completion of installation of electrical grounding system, test resistance of each ground rod installation using the "Fall of Potential" method. Ground resistances shall be measured in normally dry conditions not less than 48 hours after rainfall and at low tide. Where tests show resistance to ground is over the specified value, take appropriate action to reduce resistance by driving additional sections of ground rods and then retest to demonstrate compliance. Tests shall be conducted in the presence of the Project Electrical Engineer. Provide forms to record the data as the tests are conducted. Forms shall be signed by the person conducting the test and included with project closeout documents.
- D. Test the effectiveness of the grounding system in patient care areas as required by NFPA 99.

IT DEPARTMENT RENOVATION

GROUNDING AND BONDING FOR
ELECTRICAL SYSTEMS
26 05 26

END OF SECTION 260526

SECTION 260529 – HANGERS AND SUPPORTS FOR ELECTRICAL SYSTEMS

PART 1 - GENERAL

1.1 SUMMARY

- A. This section includes the requirements for the following:
 - 1. Conduit and equipment supports.
 - 2. Anchors and fasteners.

1.2 SUBMITTALS

- A. Refer to section 260510.

1.3 QUALITY ASSURANCE

- A. Conform to requirements of NFPA 70.
- B. Products: Listed and classified by Underwriters Laboratories Inc. as suitable for the purpose specified and indicated.

1.4 REFERENCE STANDARDS

- A. NECA 1 - Standard Practices for Good Workmanship in Electrical Contracting; National Electrical Contractors Association; current edition.

PART 2 - PRODUCTS.

2.1 MATERIALS

- A. Hangers, Supports, Anchors, and Fasteners - General: Corrosion-resistant materials of size and type adequate to carry the loads of equipment and conduit, including weight of wire in conduit.
- B. Supports: Fabricated of structural steel or formed steel members; galvanized, or PVC.
- C. Anchors and Fasteners:
 - 1. Do not use powder-actuated anchors.
 - 2. Concrete Structural Elements: Use precast inserts, expansion anchors, or preset inserts.
 - 3. Steel Structural Elements: Use beam clamps, steel spring clips, steel ramset fasteners, or welded fasteners.
 - 4. Concrete Surfaces: Use self-drilling anchors or expansion anchors.
 - 5. Hollow Masonry, Plaster, and Gypsum Board Partitions: Use toggle bolts or hollow wall fasteners.
 - 6. Solid Masonry Walls: Use expansion anchors or preset inserts.
 - 7. Sheet Metal: Use sheet metal screws.
 - 8. Wood Elements: Use wood screws.

PART 3 - EXECUTION

3.1 INSTALLATION

- A. Install hangers and supports as required to adequately and securely support electrical system

components, in a neat and workmanlike manner, as specified in NECA 1.

1. Do not fasten supports to pipes, ducts, mechanical equipment, or conduit.
- B. Cutting or Holes:
1. Locate holes in advance where they are proposed in the structural sections such as ribs or beams. Obtain the approval of the Architect prior to drilling through structural sections.
 2. Cut holes through concrete and masonry in new and existing structures with a diamond core drill or concrete saw. Pneumatic hammer, impact electric, hand or manual hammer type drills are not allowed, except where permitted by the Architect as required by limited working space.
- C. Rigidly weld support members or use hexagon-head bolts to present neat appearance with adequate strength and rigidity. Use spring lock washers under all nuts.
- D. Install surface-mounted cabinets and panelboards with minimum of four anchors.
- E. In wet and damp locations use steel channel supports to stand cabinets, disconnects and panelboards 1 inch (25 mm) off wall.
- F. Use sheet metal channel to bridge studs above and below cabinets and panelboards recessed in hollow partitions.
- G. Use stamped steel bridges to fasten flush mounting outlet box between studs.
- H. Use adjustable steel channel fasteners for hung ceiling outlet box.
- I. Do not fasten boxes to ceiling support wires.
- J. Support boxes independently of conduit, except cast box that is connected to two rigid metal conduits both supported within 12 inches of box.
- K. Support conduit using coated steel or malleable iron straps, lay-in adjustable hangers, clevis hangers, and split hangers.
- L. Group related conduits; support using conduit rack. Construct rack using steel channel; provide space on each for 25 percent additional conduits
- M. Do not support conduit with wire, wire ties, or perforated pipe straps. Remove wire used for temporary supports.
- N. Do not attach conduit to ceiling support wires.

END OF SECTION 260529

SECTION 260533 – RACEWAY AND BOXES FOR ELECTRICAL SYSTEMS

PART 1 - GENERAL

1.1 SUBMITTALS

- A. Refer to section 260510

1.2 QUALITY ASSURANCE

- A. Products: Listed and classified by Underwriters Laboratories Inc. as suitable for purpose specified and shown.

1.3 REFERENCE STANDARDS

- A. ANSI C80.1 - American National Standard for Electrical Rigid Steel Conduit (ERSC); current edition
- B. ANSI C80.3 - American National Standard for Steel Electrical Metallic Tubing (EMT); current edition
- C. ANSI C80.5 - American National Standard for Electrical Rigid Aluminum Conduit (ERAC); current edition
- D. NECA 1 - Standard Practices for Good Workmanship in Electrical Contracting; National Electrical Contractors Association; current edition
- E. NECA 101 - Standard for Installing Steel Conduit (Rigid, IMC, EMT); National Electrical Contractors Association; current edition
- F. NEMA FB 1 - Fittings, Cast Metal Boxes, and Conduit Bodies for Conduit, Electrical Metallic Tubing, and Cable; National Electrical Manufacturers Association; current edition

1.4 DELIVERY, STORAGE, AND HANDLING

- A. Accept conduit on site. Inspect for damage
- B. Protect conduit from corrosion and entrance of debris by storing above grade. Provide appropriate covering.

PART 2 - PRODUCTS

2.1 CONDUIT REQUIREMENTS

- A. Conduit Size: Comply with NFPA 70.
 - 1. Minimum Size: 3/4 inch
- B. Wet and Damp Locations:
 - 1. Exterior above ground and in pipe basements: RMC, IMC, or LFMC (LFMC shall be only used with restrictions, see conduit installation)
 - 2. Exterior below ground: RNC schedule 40
 - 3. Interior: RMC, IMC, or LFMC (LFMC shall be only used with restrictions, see conduit installation)
 - 4. Interior below grade: RNC schedule 40

5. Where RNC Schedule 40 is installed below grade or under floor slabs, the elbows required to turn the raceway up through the slab shall be RMC.
- C. Dry Locations:
1. Concealed: Use EMT or FMC (FMC shall be only used with restrictions, see conduit installation)
 2. Exposed: Use EMT or FMC (FMC shall be only used with restrictions, see conduit installation)
 3. Interior below grade: RNC schedule 40
- D. Area subject to physical damage: RMC, IMC, or LFMC (LFMC shall be only used with restrictions, see conduit installation)
1. "Areas subject to physical damage" shall be defined as the most stringent of the following:
 - a. Exposed conduit below eight feet above finished floor.
 - b. As interpreted by the authority having jurisdiction (AHJ).

2.2 METAL CONDUIT

- A. Rigid Steel Galvanized Conduit (RMC): ANSI C80.1.
- B. Intermediate Metal Conduit (IMC): ANSI C80.6.
- C. Fittings and Conduit Bodies: NEMA FB 1; material to match conduit.
1. Fittings shall meet the requirements of UL 514B and ANSI/ NEMA FB1.
 2. Standard threaded couplings, locknuts, bushings, and elbows: Only steel or malleable iron materials are acceptable. Integral retractable type IMC couplings are also acceptable.
 3. Die-cast or pressure-cast zinc-alloy fittings or fittings made of "pot metal" are prohibited.
 4. Locknuts: Bonding type with sharp edges for digging into the metal wall of an enclosure.
 5. Bushings: Metallic insulating type, consisting of an insulating insert molded or locked into the metallic body of the fitting. Bushings made entirely of metal or nonmetallic material are not permitted.
 6. Sealing fittings: Threaded cast iron type. Use continuous drain type sealing fittings to prevent passage of water vapor. In concealed work, install fittings in flush steel boxes with blank cover plates having the same finishes as that of other electrical plates in the room.

2.3 FLEXIBLE METAL CONDUIT

- A. FLEXIBLE METAL CONDUIT (FMC) Description: Interlocked steel construction. Flexible metal conduit shall conform to UL 1.
- B. Fittings: NEMA FB 1.
1. Conform to UL 514B. Only steel or malleable iron materials are acceptable.
 2. Die-cast or pressure-cast zinc-alloy fittings or fittings made of "pot metal" are prohibited.
 3. Clamp type, with insulated throat.

2.4 LIQUIDTIGHT FLEXIBLE METAL CONDUIT

- A. LIQUIDTIGHT FLEXIBLE METAL CONDUIT (LFMC) Description: Interlocked steel

construction with PVC jacket. Liquid-tight flexible metal conduit: Shall Conform to UL 360.

- B. Fittings: UL 514B and ANSI/ NEMA FB1.
 - 1. Only steel or malleable iron materials are acceptable.
 - 2. Die-cast or pressure-cast zinc-alloy fittings or fittings made of "pot metal" are prohibited.
 - 3. Fittings must incorporate a threaded grounding cone, a steel or plastic compression ring, and a gland for tightening. Connectors shall have insulated throats.
 - 4. Coating for Fittings for PVC-Coated Conduit: Minimum thickness, 0.040 inch, with overlapping sleeves protecting threaded joints.

2.5 ELECTRICAL METALLIC TUBING

- A. ELECTRICAL METALLIC TUBING (EMT) Description: ANSI C80.3
- B. Fittings and Conduit Bodies: NEMA FB 1; steel compression type.
 - 1. Fittings shall meet the requirements of UL 514B and ANSI/ NEMA FB1.
 - 2. Only steel or malleable iron materials are acceptable.
 - 3. Die-cast or pressure-cast zinc-alloy fittings or fittings made of "pot metal" are prohibited.
 - 4. Couplings and connectors: Concrete tight and rain tight, with connectors having insulated throats. Use gland and ring compression type couplings and connectors for conduit sizes 50mm (2 inches) and smaller. Use set screw type couplings with four set screws each for conduit. Use set screws of case-hardened steel with hex head and cup point to firmly seat in wall of conduit for positive grounding.
 - 5. Indent type connectors or couplings are prohibited.

2.6 NONMETALLIC CONDUIT

- A. RIGID NONMETALLIC CONDUIT (RNC): Direct burial plastic conduit: Shall conform to UL 651 and UL 651A, heavy wall PVC or high density polyethylene (PE).
- B. RNC: NEMA TC 2, schedule 40 PVC
- C. Fittings shall meet the requirements of UL 514C and NEMA TC3
- D. Fittings for RNC: NEMA TC 3; match to conduit or tubing type and material.

2.7 EXPANSION AND DEFLECTION COUPLINGS

- A. Conform to UL 467 and UL 514B.
- B. Accommodate, 0.75 inch deflection, expansion, or contraction in any direction, and allow 30 degree angular deflections.
- C. Include internal flexible metal braid sized to guarantee conduit ground continuity and fault currents in accordance with UL 467, and the NEC code tables for ground conductors.
- D. Jacket: Flexible, corrosion resistant, watertight, moisture and heat resistant molded rubber material with stainless steel jacket clamps.

2.8 CORROSION PROTECTION

- A. Corrosion protection for conduits passing through concrete slabs shall be by one of the

following means: field-wrapped with 3M Scotchrap No. 50, 2-inch wide (minimum), with a 50 percent overlay, or shall have a factory-applied polyvinyl chloride, plastic resin, or epoxy coating.

2.9 FLOOR BOXES:

- A. For all other locations (non-furniture feed applications): Evolution Series poke-thru device by Legrand or comparable product by one of the following, contingent upon compliance with the Contract Documents:
 - 1. Hubbell Wiring Systems
 - 2. FSR Inc.
- B. For all other furniture feed locations: Evolution Series poke-thru device dual-service Furniture Feed by Legrand or comparable product by one of the following, contingent on compliance with the contract documents:
 - 1. Hubbell Wiring Systems
 - 2. FSR Inc.
- C. All floor boxes and poke-thrus to be recessed service. Flush service boxes are not acceptable.
- D. All poke-thrus to be UL listed for installation in a 2-hour fire-rated floor.
- E. Provide floor boxes and poke-thrus with all necessary appurtenances to make a fully functioning system and incorporate wiring devices, low-voltage, and A/V connections indicated on plans.
- F. Cover to be UL listed for scrub water. Cover to have in-use hinged cable access doors. Finish of cover shall be selected by Architect and shall be compatible with specified floor finish or covering.

PART 3 - EXECUTION

3.1 EXAMINATION

- A. Verify routing and termination locations of conduit prior to rough-in.
- B. Conduit routing is shown on drawings in approximate locations unless dimensioned. Route as required to provide a complete wiring system.

3.2 CONDUIT INSTALLATION

- A. All fire alarm cable shall be installed in metallic conduit. Coordinate with fire alarm system manufacturer for cable routing and quantities.
- B. Install conduit securely, in a neat and workmanlike manner, as specified in NECA 101.
- C. Waterproofing: At floor, exterior wall, and roof conduit penetrations, completely seal clearances around the conduit and make watertight.
- D. Arrange supports to prevent misalignment during wiring installation.
- E. Arrange conduit to maintain headroom and present neat appearance.

- F. Route exposed conduit parallel and perpendicular to walls.
- G. Route conduit installed above accessible ceilings parallel and perpendicular to walls.
- H. Route conduit in and under slab from point-to-point.
- I. Maintain adequate clearance between conduit and piping.
- J. Maintain 12 inch (300 mm) clearance between conduit and surfaces with temperatures exceeding 104 degrees F (40 degrees C).
- K. Cut conduit square using saw or pipecutter; de-burr cut ends.
- L. Bring conduit to shoulder of fittings; fasten securely.
- M. For power conduits install no more than equivalent of three 90 degree bends between boxes. Use conduit bodies to make sharp changes in direction, as around beams. Use hydraulic one shot bender to fabricate bends in metal conduit larger than 2 inch (50 mm) size.
- N. For communication conduits install no more than the equivalent of two 90 degree bends between pull points. Use conduit bodies to make sharp changes in direction, as around beams. Use hydraulic one shot bender to fabricate bends in metal conduit larger than 2 inch (50 mm) size.
- O. Avoid moisture traps; provide junction box with drain fitting at low points in conduit system.
- P. Provide suitable fittings to accommodate expansion and deflection where conduit crosses seismic, control, and expansion joints.
- Q. Seal the inside of all conduits where conduit passes below floor or outside of the building.
- R. Provide suitable pull string in each empty conduit except sleeves and nipples.
- S. Use suitable caps to protect installed conduit against entrance of dirt and moisture.
- T. Do not install FMC or LFMC in lengths over 6'.
- U. Use LFMC or FMC only to connect to equipment subject to vibration or to suspended light fixtures.
- V. Wherever possible, install horizontal raceway runs above water and drain piping. Give the right-of-way in confined spaces to piping that must slope for drainage and to larger HVAC ductwork and similar services that are less conformable than electrical services.
- W. Complete the installation of electrical raceways before starting installation of cables within raceways.
- X. Raceways shall not be installed exposed in finished spaces. Install concealed in walls, ceilings, below slab-on-grade or embedded in slabs above grade.

3.3 BOX INSTALLATION

- A. Boxes for Concealed Conduits:
 - 1. Flush mounted.

2. Provide raised covers for boxes to suit the wall or ceiling, construction and finish.
- B. In addition to boxes shown, install additional boxes where needed to prevent damage to cables and wires during pulling in operations.
 - C. Remove only knockouts as required and plug unused openings. Use threaded plugs for cast metal boxes and snap-in metal covers for sheet metal boxes.
 - D. Outlet boxes in the same wall mounted back-to-back are prohibited. A minimum 24 inch, center-to-center lateral spacing shall be maintained between boxes.
 - E. Minimum size of outlet boxes for ground fault interrupter (GFI) receptacles is 4 inches square by 2-1/8 inches deep, with device covers for the wall material and thickness involved.
 - F. Clean all debris out of floor boxes.

3.4 IDENTIFICATION

- A. Stencil or install phenolic nameplates on covers of the boxes identified on riser diagrams; for example "SIG-FA JB No. 1"
- B. On all concealed junction box covers, identify the circuits with black marker. For exposed junction boxes use printed labels.

END OF SECTION 260533

SECTION 260536 – CABLE TRAYS FOR ELECTRICAL SYSTEMS

PART 1 - GENERAL

1.1 SUMMARY

- A. This section includes the requirements for the following:
- B. Provide cable tray system in areas indicated, complete with all supports, fittings and accessories.
- C. Furnishing, installation and connection of raceway systems and wiring for the radiology equipment.

1.2 SUBMITTALS

- A. Refer to section 260510.

1.3 QUALITY ASSURANCE

- A. Products: Listed and classified by Underwriters Laboratories Inc. as suitable for purpose specified and shown
- B. The drawings, which constitute a part of these specifications, indicate the general route of the cable tray systems. Data presented on these drawings is as accurate as preliminary surveys and planning can determine until final equipment selection is made. Accuracy is not guaranteed and field verification of all dimensions, routing, etc., is required by the contractor.
- C. Drawings are for assistance and guidance, but exact routing, locations, distances and levels will be governed by actual field conditions. Contractor is directed to make field surveys as part of his work prior to submitting system layout drawings.

PART 2 - PRODUCTS

2.1 WIRE BASKET STYLE CABLE TRAY

- A. Acceptable manufacturers, contingent upon compliance with the contract documents, are as listed below. Bidders shall carefully review the requirements listed in the technical specifications and only submit products that are equal or better. Equal products by other manufacturers are acceptable providing substitutions are submitted in accordance with requirements listed in the "Instructions to Bidders" and "Supplemental Instructions to Bidders" (AIA A701) and approved by the A/E. Bidders shall carefully review the front end documents (AIA A701) and submit all information required to allow the A/E the ability to make a fully informed decision.
 - 1. Basis of design manufacturers
 - a. Mono-Systems, Inc.
 - b. Atlas
 - c. B-line
- B. Wire basket shall be made of high strength steel wires and formed into a standard 2 inch by 4 inch wire mesh pattern with intersecting wires welded together. All mesh sections must have at least one bottom longitudinal wire along entire length of straight section.
- C. Wire basket shall have a 4 inch usable loading depth by width shown on plans.

PART 3 - EXECUTION

3.1 LAYOUT

- A. Layout of cable tray is the responsibility of the Contractor. Coordinate location with building structure and other trades to ensure that the tray is readily accessible. Tray shall not be installed more than 18" above ceilings, without written permission by the Architect.
- B. Provide sufficient space encompassing wire basket to permit access for installing and maintaining cables.

3.2 INSTALLATION

- A. Provide all connector assemblies, clamp assemblies, connector plates, splice plates and splice bars, and mounting hardware required for a complete system.
- B. Splice Connectors: Sections of tray shall be joined using a two bolt rectangular splice connector which telescopes into the spine of the tray. Splice connectors shall allow for thermal expansion/contraction of the tray system.
- C. Supporting: The tray shall be supported on 12- foot centers, maximum
- D. Bracing and Leveling: Brace trays on intervals required to prevent lateral movement. After installation of cables by other trades, adjust supports and braces so that tray is level.
- E. Trough-type raceway sections and cable tray sections shall be made electrically continuous by short bonding jumpers between adjacent sections.
- F. Ground all cable tray and trough.
- G. Fittings: All fittings, inserts, covers, couplings, connectors and other accessories required to effect a complete rigid mechanical installation shall be provided and shall be listed as suitable for use with cable tray.
- H. Bushings: Provide conduit bushings and bond to ground, attached to tray, to accommodate conduit sleeves terminated at tray or trough. Conduits shall be supported within 6" of tray, independent of tray supports.
- I. Cable tray and trough loading: Provide cross-section of cable tray for every wing/area to show proposed location/spacing of cables. Layout of cables in tray is the contractor's responsibility. Maintain required spacing between cables of different systems while leaving room for the future installation of 25% additional cables.

END OF SECTION 260536

SECTION 260548 – VIBRATION AND SEISMIC CONTROLS FOR ELECTRICAL SYSTEMS

PART 1 - GENERAL

1.1 SUBMITTALS

- A. Refer to section 260510.

1.2 QUALITY ASSURANCE

- A. Submittals must be signed and sealed shop drawings from a professional engineer licensed in the state that the project is located in. Shop drawings to include project specific details, sketches, product data cut sheets.
- B. The contractor shall provide pre-engineered seismic restraint systems to meet total design lateral force requirements for support and restraint of piping, conduit, cable trays and other similar systems and equipment where required by the applicable building code.
- C. System Supports/Restraints Manufacturers shall be firms regularly engaged in the manufacture of products of the types specified in this section, whose products have been in satisfactory use in similar service for not less than 5 years.

PART 2 - PRODUCT

2.1 SEISMIC BRACING

- A. General:
 - 1. Seismic restraint designer shall coordinate all attachments with the structural engineer of record.
 - 2. Design analysis shall include calculated dead loads, static seismic loads, and capacity of materials utilized for the connection of the equipment or system to the structure.
 - 3. Analysis shall detail anchoring methods, bolt diameter, and embedment depth.
 - 4. All seismic restraint devices shall be designed to accept without failure the forces calculated per the details and notes on the construction documents
- B. Friction from gravity loads shall not be considered resistance to seismic forces.

PART 3 - EXECUTION

3.1 INSTALLATION

- A. All seismic restraint systems shall be installed in strict accordance with the manufacturer's seismic restraint guidelines manual and all certified submittal data
- B. Installation of seismic restraints shall not cause any change in position of equipment or piping, resulting in stresses or misalignment.
- C. No rigid connections between equipment and the building structure shall be made that degrade the noise and vibration-isolation system specified.
- D. Do not install any equipment, piping, duct, or conduit that makes rigid connections with the building.
- E. Prior to installation, bring to the architect's/engineer's attention any discrepancies between the specifications and the field conditions, or changes required due to specific equipment

selection.

- F. Bracing may occur from flanges of structural beams, upper truss cords of bar joists, cast in place inserts, or wedge-type concrete anchors. Consult structural engineer of record.
- G. Overstressing of the building structure shall not occur from overhead support of equipment. Bracing attached to structural members may present additional stresses. The contractor shall submit loads to the structural engineer of record for approval in this event.
- H. Brace support rods when necessary to accept compressive loads. Welding of compressive braces to the vertical support rods is not acceptable.
- I. Provide reinforced clevis bolts where required.
- J. Seismic restraints shall be mechanically attached to the system. Looping restraints around the system is not acceptable.
- K. Do not brace a system to two independent structures such as a ceiling and wall.
- L. Provide appropriately sized openings in walls, floors, and ceilings for anticipated seismic movement.
- M. Provide seismic controls as required for all existing electrical items exposed during renovations.

3.2 FIELD QUALITY CONTROL

- A. Inspect all seismic supports after installation and submit a report from a professional engineer licensed in the state that the project is located in.

END OF SECTION 260548

SECTION 260553 – IDENTIFICATION FOR ELECTRICAL SYSTEMS

PART 1 - GENERAL

1.1 SUBMITTALS

- A. Refer to section 260510.

PART 2 - PRODUCTS

2.1 NAMEPLATES AND LABELS

- A. Nameplates: Engraved three-layer laminated plastic, black letters on white background unless noted otherwise.
- B. Locations:
 - 1. Each electrical distribution and control equipment enclosure.
- C. Letter Size:
 - 1. Use 1/4 inch (6 mm) letters for identifying grouped equipment and loads.
- D. Labels: Embossed adhesive tape, with 3/16 inch (5 mm) black letters on white background. Use only for identification of individual wall switches, receptacles, and control device stations. Labels shall identify the panel and circuit number (Ex: PANEL: CIRCUIT).
- E. Plenum-Rated Cable Ties: Self extinguishing, UV stabilized, one piece, self locking.
 - 1. Minimum Width: 3/16 inch (5 mm).
 - 2. Tensile Strength at 73 deg F (23 deg C), According to ASTM D 638: 7000 psi (48.2 MPa).
 - 3. UL 94 Flame Rating: 94V-0.
 - 4. Temperature Range: Minus 50 to plus 284 deg F (Minus 46 to plus 140 deg C).
 - 5. Color: burgundy.

PART 3 - EXECUTION

3.1 PREPARATION

- A. Degrease and clean surfaces to receive nameplates and labels.

3.2 INSTALLATION

- A. Install nameplates and labels parallel to equipment lines.
- B. Secure nameplates to equipment front using corrosion resistant screws.
- C. Secure nameplates to inside surface of door on panelboard that is recessed in finished locations.
- D. Provide name plates on all disconnects, panelboards, switchboards, switchgear, transformers, and motor starters.
- E. Provide labels on all receptacles, light switches, and wall mounted occupancy sensors.

END OF SECTION 260553

SECTION 262400 –PANELBOARDS

PART 1 - GENERAL

1.1 SUBMITTALS

- A. See section 260510.

1.2 QUALITY ASSURANCE

- A. Where switchboards or panelboards are used as service entrance equipment, they shall comply with all NEC and UL requirements for service entrance and a UL service entrance label shall be provided.
- B. Products: Listed and classified by Underwriters Laboratories Inc. as suitable for the purpose specified and indicated.

1.3 REFERENCE STANDARDS

- A. NECA 1 - Standard Practices for Good Workmanship in Electrical Contracting; National Electrical Contractors Association; current edition.
- B. NEMA PB 1 - Panelboards; National Electrical Manufacturers Association; current edition.
- C. NEMA PB 1.1 - General Instructions for Proper Installation, Operation and Maintenance of Panelboards Rated 600 Volts or Less; National Electrical Manufacturers Association; current edition.
- D. NETA STD ATS - Acceptance Testing Specifications for Electrical Power Distribution Equipment and Systems; International Electrical Testing Association; current edition.

PART 2 - PRODUCTS

2.1 MANUFACTURERS

- A. Eaton Electrical/Cutler-Hammer
- B. GE Industrial
- C. Square D
- D. Siemens

2.2 PANELBOARDS

- A. Description: NEMA PB1, circuit breaker type, lighting and appliance branch circuit panelboard.
- B. Panelboard Bus: Copper (98% conductivity).
- C. Provide copper ground bus in each panelboard
- D. Enclosure: Interior - NEMA 1
- E. Cabinet Front: Flush cabinet front with concealed trim clamps, concealed hinge, metal directory frame, and flush lock all keyed alike. Finish in manufacturer's standard gray

enamel. Paint all hallway panels to match wall finish.

- F. All panelboards shall be hinged "door in door" type with:
 - 1. Interior hinged door with hand operated latch or latches as required to provide access to circuit breaker operating handles only, not to energized ports.
 - 2. Outer hinged door shall be securely mounted to the panelboard box with factory bolts, screws, clips or other fasteners requiring a tool for entry, hand operated latches are not acceptable.
 - 3. Push inner and outer doors shall open left to right.
- G. All panelboard shall have bolt-on style breakers.
- H. Provisions for future breakers shall be fully bussed complete with all necessary mounting hardware.

2.3 CIRCUIT BREAKERS

- A. For circuit breakers over 200 amps provide -Adjustable Trip molded case, solid state adjustable trip type circuit breakers.
 - 1. Ground-Fault Equipment Protection (GFEP) Circuit Breakers: Class B ground-fault protection (30-mA trip). (where indicated)
 - 2. Ground-Fault Protection: Integrally mounted relay and trip unit with adjustable pickup and time-delay settings, push-to-test feature, and ground-fault indicator. (where indicated)
 - 3. Shunt Trip: 24-V trip coil energized from separate circuit, set to trip at 75 percent of rated voltage. (where indicated)
 - 4. Undervoltage Trip: Set to operate at 35 to 75 percent of rated voltage with field-adjustable 0.1- to 0.6-second time delay. (where indicated)
 - 5. Auxiliary Contacts: Two SPDT switches with "a" and "b" contacts; "a" contacts mimic circuit-breaker contacts and "b" contacts operate in reverse of circuit-breaker contacts. (where indicated)
 - 6. Trip units shall have field adjustable tripping characteristics as follows:
 - a. Ampere setting (continuous).
 - b. Long time band.
 - c. Short time trip point.
 - d. Short time delay.
 - e. Instantaneous trip point.
- B. For all circuit breakers 200 amps and smaller provide - Molded Case Circuit Breakers: Thermal magnetic trip circuit breakers.
 - 1. Type SWD for lighting circuits.
 - 2. Type HACR for air conditioning equipment circuits.
 - 3. Class A ground fault interrupter circuit breakers where scheduled.
 - 4. Do not use tandem circuit breakers.
 - 5. Arc-Fault Circuit Interrupter (AFCI) Circuit Breakers: Comply with UL 1699; 120/240-V, single-pole configuration for all residential applications.
 - 6. GFCI Circuit Breakers: Single- and two-pole configurations with Class A ground-fault protection (6-mA trip). (where indicated)
- C. Circuit breakers serving elevators shall have adjustable long-time setting and shall be provided with a shunt trip coil rated for 120V operation. Breaker shall also have a set of Form C contacts. Connect shunt trip coil to operate as indicated on the drawings.
- D. Key Interlock Kit: Externally mounted to prohibit circuit-breaker operation; key shall be removable only when circuit breaker is in off position.

- E. Circuit breakers serving fire alarm devices shall be provided with a red fire alarm circuit breaker lockout kit that permanently identifies circuit as "FIRE ALARM".
- F. Circuit breakers serving emergency communication devices (e.g. mass notification, area of refuge, two way communication) shall be provided with a circuit breaker locking device and be permanently identified as "EMERGENCY COMMUNICATIONS".

2.4 CONTROL WIRING:

- A. Control wiring shall be 600 volt class B stranded SIS. Install all control wiring complete at the factory adequately bundled and protected. Wiring across hinges and between shipping units shall be Class C stranded. Size in accordance with NEC. Provide control circuit fuses. Provide integral power supply in switchgear for control power.

2.5 SHORT CIRCUIT CURRENT RATING:

- A. Devices which achieve the level of fault protection indicated by means of "series" or "integrated" rating shall not be acceptable unless specifically indicated on the drawings. All panelboards shall be fully rated.
- B. Minimum SSCR
 1. 208 Volt Panelboards: Minimum 10,000 amperes rms symmetrical unless noted otherwise on plans.
 2. 480 Volt Panelboards: Minimum 22,000 amperes rms symmetrical unless noted otherwise on plans.
 3. Match existing equipment short circuit current ratings.

PART 3 - EXECUTION

3.1 INSTALLATION

- A. Install panelboards in accordance with NEMA PB 1.1 and NECA 1.
- B. Install panelboards plumb. Install recessed panelboards flush with wall finishes.
- C. Height: 6 feet (1800 mm) to top of panelboard; install panelboards taller than 6 feet (1800 mm) with bottom no more than 4 inches (100 mm) above floor.
- D. Provide filler plates for unused spaces in panelboards.
- E. Provide typed circuit directory for each branch circuit panelboard. Revise directory to reflect circuiting changes required to balance phase loads.
- F. Provide engraved plastic nameplates on all switchboard and panelboards.
- G. Ground and bond panelboard and switchboard enclosure according to Section 26 05 26.
- H. Do not splice conductors in panelboard or switchboard enclosure.
- I. Install switchboard on 4" high concrete pad with 3" minimum overlap on all sides. Bolt switchboard to pad in all four corners, minimum.
- J. Each section of two section panels shall contain only those conductors which originate in that section. Do not use panel as a wireway.

- K. Piggy-back or tandem type breakers shall not be used.
- L. Multi-pole breakers shall be common trip, with a single handle.

3.2 FIELD QUALITY CONTROL

- A. Inspect and test in accordance with NETA STD ATS, except Section 4.
- B. Perform inspections and tests listed in NETA STD ATS, Section 7.5 for switches, Section 7.6 for circuit breakers.

3.3 ADJUSTING

- A. Adjust the breaker trip set points per the values provided by the engineer, per an Overcurrent protective device study provided by the contractor.
- B. Touch-up scratched or marred surfaces to match original finish.
- C. Clean all debris from panel interiors.

3.4 LABELING

- A. Provide nameplates on all electrical panels that new circuits are modified or installed. Indicate the following information:
 - 1. Panel name
 - 2. Panel fed from
 - 3. Normal (Black with white letters)
 - 4. Voltage, phase, wire
 - 5. Date installed
- B. Provide a typed legend for all modified or new electrical panels. Update the panel board schedules after load balancing.
- C. Identify load served and location by room names assigned by user, not by room numbers on floor plans. Note spares and spaces as such.
- D. For switchboards Provide laminated plastic nameplate for main and for each feeder circuit. Nameplates shall be secured to switchboard with two screws.
- E. Provide a laminated 11x17 one line in the main electrical room mounted to the wall or main electrical panel.
- F. Provide ARC flash identification per NFPA 70E.

3.5 CLEARANCE AND WORKSPACE

- A. Maintain workspace and clearances as required by the NEC for the voltage encountered. No pipes or ducts shall pass above the outline of the panelboard. It shall be the responsibility of this Contractor to make sure that other trades do not encroach on this space.

END OF SECTION 262400

SECTION 262726 – WIRING DEVICES

PART 1 - GENERAL

1.1 SUMMARY

- A. This section includes the requirements for the following:
 - 1. Receptacles.
 - 2. Device plates.
 - 3. Wall switches.
 - 4. Wall dimmers.
 - 5. Occupancy Sensors
 - 6. Motion Sensors

1.2 SUBMITTALS

- A. Refer to section 260510.

1.3 QUALITY ASSURANCE

- A. Conform to requirements of NFPA 70.
- B. Manufacturer Qualifications: Company specializing in manufacturing the products specified in this section with minimum three years documented experience.
- C. Products: Provide products listed and classified by Underwriters Laboratories Inc. as suitable for the purpose specified and indicated.

1.4 OCCUPANCY SENSOR DRAWING

- A. Drawing Format: Drawings shall be prepared at a scale of no less than 1/16"=1'-0". Drawing shall be titled to define Project Name, Drawing subject and date prepared. Drawings are to be prepared in AutoCAD 2017 or compatible software.

1.5 REFERENCE STANDARDS

- A. NECA 1 - Standard Practices for Good Workmanship in Electrical Contracting; National Electrical Contractors Association; current edition.
- B. NEMA WD 1 - General Color Requirements for Wiring Devices; National Electrical Manufacturers Association; current edition).
- C. NEMA WD 6 - Wiring Device -- Dimensional Requirements; National Electrical Manufacturers Association; current edition.

PART 2 - PRODUCTS

2.1 APPROVED MANUFACTURERS

- A. Acceptable manufacturers, contingent upon compliance with the contract documents, are as listed below. Bidders shall carefully review the requirements listed in the technical specifications and only submit products that are equal or better. Equal products by other manufacturers are acceptable providing substitutions are submitted in accordance with requirements listed in the front end specifications and approved by the A/E. Bidders shall carefully review the front end documents and submit all information required to allow the A/E

the ability to make a fully informed decision.

1. Cooper Wiring Devices
2. GE Industrial
3. Leviton Manufacturing, Inc
4. Hubbell, Inc
5. Lutron Electronics Inc
6. Wattstopper Inc
7. Schneider Electric
8. Legrand – Pass & Seymour
9. C.W. Cole & Company
10. Acuity Brands Lighting, Inc

2.2 RECEPTACLES

- A. Receptacles: Specification Grade Receptacles, Fed spec listed complying with NEMA WD 6 and WD 1.
 1. Device Body: color by architect plastic, or Red for emergency power devices.
 2. Configuration: NEMA WD 6, type as specified and indicated.
 3. Type 5-20.
- B. GFCI Receptacles: Convenience receptacle with integral ground fault circuit interrupter to meet regulatory requirements. Feed through GFCI devices shall not be used. GFCI devices shall contain self-testing feature with power lockout if self-test fails.
- C. Special Purpose Receptacles: Provide heavy-duty type as indicated on the drawings.
- D. Provide duplex receptacles with two integral USB power charges (3 Amps total capacity) where indicated on the drawings.
- E. Wet Location: A receptacle installed in a wet location shall be GFCI listed weather-resistant type.

2.3 WALL PLATES

- A. Cover Plates: Provide one piece wall plates for wiring devices, with ganging and cutouts as required. Provide blank wall plates for all un-used outlet boxes. Provide with metal screws for securing plates to devices, screw heads colored to match finish of plate. All plates shall be standard size, Impact resistant Nylon.
- B. Weatherproof Cover Plates: All devices installed outdoors and indoor devices specifically indicated, shall be provided with weatherproof covers. Covers shall be of the type that maintains weatherproof integrity when in-use and not in-use. Covers shall be listed and identified as “extra duty” type.

2.4 WALL SWITCHES

- A. Wall Switches: Heavy Duty, AC only general-use snap switch, complying with NEMA WD 6 and WD 1.
 1. Body and Handle: color by architect plastic with toggle handle,
 2. Locator Light: Lighted handle type switch
 3. Ratings: Match branch circuit and load characteristics.
- B. Switch Types: Single pole, double pole, 3-way, and 4-way.

2.5 WALL DIMMERS

- A. Electronic Wall Dimmers: Coordinate with electronic dimming driver requirements.
 - 1. Body and Handle: plastic with slide adjuster or a three button configuration (up, down, on/off).

2.6 OCCUPANCY SENSORS

- A. Wall switch sensors: Passive Infrared type.
 - 1. Capable of detection of occupancy at desktop level up to 300 sqft, and gross motion up to 1000 sqft with 180 degree coverage capability.
 - 2. Rating: Sensor rating shall be at least 125% of the connected load.
 - 3. Sensor shall utilize Zero Crossing Circuitry.
 - 4. Sensor shall have no leakage current to load, and voltage drop protection.
 - 5. Sensor shall provide high immunity to false triggering from RFI and EMI.
 - 6. Sensor shall be capable of operating normally with electronic ballasts, PL lamp systems and rated motor loads.
 - 7. Sensor shall utilize automatically adjustable time delay and sensitivity settings.
 - 8. Coverage of sensors shall remain constant after sensitivity control has been set. No automatic reduction shall occur in coverage due to the cycling of air conditioner or heating fans.
 - 9. A bypass manual override shall be provided on each sensor.
 - 10. An integral photo cell with adjustable light level shall be provided
 - 11. All sensors shall have UL rated, 94V-0 plastic enclosures.

- B. Ceiling Sensors: Dual Technology type.
 - 1. Rating: Sensor rating shall be at least 125% of the connected load.
 - 2. Sensor shall be ceiling mounted in such a way as to minimize coverage in unwanted areas.
 - 3. Sensor shall consist of passive infrared and ultrasonic technologies for occupancy detection. Products that react to noise or ambient sound shall not be considered.
 - 4. Passive Infrared Sensor shall provide high immunity to false triggering from RFI and EMI.
 - 5. Ultrasonic Sensor shall adjust the detection threshold dynamically to compensate for constantly changing levels of activity and air flow throughout the controlled space.
 - 6. Sensor shall be capable of operating normally with electronic ballasts, PL lamp systems and rated motor loads.
 - 7. Sensor shall utilize automatically adjustable time delay and sensitivity settings.
 - 8. Coverage of sensors shall remain constant after sensitivity control has been set. No automatic reduction shall occur in coverage due to the cycling of air conditioner or heating fans.
 - 9. A bypass manual override shall be provided on each sensor.
 - 10. All sensors shall have UL rated, 94V-0 plastic enclosures.

- C. Circuit Control Hardware – Where required.
 - 1. Control Unit: Self-contained unit consisting internally of isolated load switching relay(s) and transformer to provide low-voltage power.
 - 2. Control Unit shall provide power to a minimum of two sensors.
 - 3. Relay Contacts shall have ratings as required for connected load.

2.7 MOTION SENSORS

- A. Exterior Motion Sensors shall have the following features:
 - 1. Rated for covered exterior applications.
 - 2. A 1 minute built-in time delay.
 - 3. Sensor shall utilize a sensitivity adjustment for wind in trees.

PART 3 - EXECUTION

3.1 EXAMINATION

- A. Verify that outlet boxes are installed at proper height.
- B. Verify that wall openings are neatly cut and will be completely covered by wall plates.
- C. Verify that branch circuit wiring installation is completed, tested, and ready for connection to wiring devices.

3.2 PREPARATION

- A. Provide extension rings to bring outlet boxes flush with finished surface.
- B. Clean debris from outlet boxes.

3.3 INSTALLATION

- A. Install securely, in a neat and workmanlike manner, as specified in NECA 1.
- B. Install devices plumb and level.
- C. Do NOT utilize back wiring on any wiring device.
- D. Install receptacles with grounding pole on top.
- E. Do not install receptacles within 6" of the edge of sinks.
- F. Connect wiring device ground terminal to outlet box with bonding jumper.
- G. All receptacles installed as listed below shall be GFCI type.
 - 1. Receptacles installed outdoors.
 - 2. Receptacles installed within six feet of sinks.
 - 3. Receptacles designated for electric drinking fountains.
 - 4. Receptacles designated for vending machines.
 - 5. Any other receptacles specifically indicated on the drawings.
 - 6. Receptacles installed in residential mechanical rooms.
- H. Install decorative plates in finished areas.
- I. Connect wiring devices by wrapping conductor around screw terminal.
- J. Provide screenprinted nylon wall plates that indicate the branch circuit to which the associated device is connected. Use 1/8" high black letters.
- K. Install switches with OFF position down.
- L. Install wall dimmers to achieve full rating specified and indicated after derating for ganging as instructed by manufacturer.
- M. Do not share neutral conductor on load side of dimmers.

3.4 FIELD QUALITY CONTROL

- A. Perform all field inspection, testing, and adjusting specified in NETA STD ATS
- B. Inspect each wiring device for defects.
- C. Verify that each receptacle device is energized.
- D. Test each receptacle device for proper polarity.
- E. Test each GFCI receptacle device for proper operation.
- F. Operate each wall switch with circuit energized and verify proper operation.
- G. Test each occupancy sensor and verify settings are appropriate for associated space.

3.5 ADJUSTING

- A. Adjust devices and wall plates to be flush and level.
- B. It shall be the contractor's responsibility to locate and aim occupancy sensors in the correct location required for complete and proper volumetric coverage within the range of coverage(s) of controlled areas per the manufacturer's recommendations. Rooms shall have ninety (90) to one hundred (100) percent coverage to completely cover the controlled area to accommodate all occupancy habits of single or multiple occupants at any location within the room(s). The locations and quantities of sensors shown on the drawings are diagrammatic and indicate only the rooms which are to be provided with sensors. The contractor shall provide additional sensors if required to properly and completely cover the respective room.
- C. Proper judgment must be exercised in executing the installation so as to ensure the best possible installation in the available space and to overcome local difficulties due to space limitations or interference of structural components. The contractor shall also provide, at the owner's facility, the training necessary to familiarize the owner's personnel with the operation, use, adjustment, and problem solving diagnosis of the occupancy sensing devices and systems.

3.6 CLEANING

- A. It is anticipated that painting and other finish work may occur after device installation. Device plates shall not be installed until these activities are completed. Protect device and conductors by installing molded plastic cover.
- B. Clean exposed surfaces to remove splatters and restore finish.

END OF SECTION 262726

SECTION 262816 – ENCLOSED SWITCHES AND CIRCUIT BREAKERS

PART 1 - GENERAL

1.1 SUBMITTALS

- A. Refer to section 260510.

1.2 QUALITY ASSURANCE

- A. Conform to requirements of NFPA 70.
- B. Manufacturer Qualifications: Company specializing in manufacturing the products specified in this section with minimum three years documented experience.
- C. Products: Furnish products listed and classified by Underwriters Laboratories Inc.; or testing firm acceptable to authority having jurisdiction as suitable for purpose specified and indicated.

1.3 REFERENCES

- A. NEMA FU 1 - Low Voltage Cartridge Fuses; National Electrical Manufacturers Association; current edition.
- B. NEMA KS 1 - Enclosed and Miscellaneous Distribution Equipment Switches (600 Volts Maximum); National Electrical Manufacturers Association; current edition.
- C. NETA STD ATS - Acceptance Testing Specifications for Electrical Power Distribution Equipment and Systems; International Electrical Testing Association; current edition.

PART 2 - PRODUCTS

2.1 MANUFACTURERS

- A. Acceptable manufacturers
 - 1. Eaton Electrical/Cutler-Hammer
 - 2. GE Industrial
 - 3. Square D
 - 4. Siemens

2.2 NON-FUSIBLE SWITCH

- A. Non-fusible Switch Assemblies: NEMA KS 1, Type HD enclosed load interrupter knife switch.
 - 1. Externally operable handle interlocked to prevent opening front cover with switch in ON position.
 - 2. Handle lockable in OFF position.

2.3 FUSIBLE SWITCH

- A. Fusible Switch Assemblies: NEMA KS 1, Type HD enclosed load interrupter knife switch.
 - 1. Externally operable handle interlocked to prevent opening front cover with switch in ON position.
 - 2. Handle lockable in OFF position.
 - 3. Fuse clips: Designed to accommodate NEMA FU1, Class R or J fuse

- B. Fusible switches serving elevators shall be provided with a set of Form C contacts.

2.4 MOLDED CASE CIRCUIT BREAKERS

- A. Molded Case Circuit Breakers for circuit breakers smaller than 200 amps: UL listed for the following service conditions: Temperature: 40 degrees C. Provide HACR rated breakers where they serve HVAC equipment.
- B. Field-Adjustable Trip Circuit Breakers: Provide circuit breakers with frame sizes 200 amperes and larger with mechanism for adjusting long time and short time current
- C. Circuit breakers serving elevators shall have adjustable long-time setting. Breaker shall also have a set of Form C contacts.

2.5 ENCLOSURES

- A. Enclosures: NEMA KS 1.
 - 1. Interior Dry Locations: Type 1.
 - 2. Exterior Locations: NEMA 3R stainless steel.
 - 3. Kitchen and locations subjected to hose down: gasketed, stainless steel, NEMA 4X Rated.

2.6 ACCESSORIES

- A. Shunt Trip Device: 120; volts, AC; provide where indicated.
24; volts, DC; provide where indicated.
- B. Undervoltage Trip Device: 120; volts, AC; provide where indicated
- C. Auxiliary NO and NC contact: 120; volts, AC; provide where indicated

PART 3 - EXECUTION

3.1 INSTALLATION

- A. Install in accordance with Manufacturer's instructions.
- B. Apply adhesive tag on inside door of each fused switch indicating NEMA fuse class and size installed.
- C. All switches associated with outdoor equipment shall be located as close to the equipment as possible (when equipment is in a service yard, switches shall also be in the service yard) and mounted such that the top of the switch is no more than 6'-6" above grade. All switches associated with equipment mounted above a lay-in ceiling shall also be located above the lay-in ceiling.
- D. Coordinate safety and disconnect switch installation with surrounding equipment to provide unobstructed access to the switch (4 foot clearance) and to insure that the switch is within sight of the controller or driven equipment.

3.2 FIELD QUALITY CONTROL

- A. Inspect and test in accordance with NETA STD ATS, except Section 4.
- B. Perform inspections and tests listed in NETA STD ATS, Section 7.5.
- C. Touch-up scratched or marred surfaces to match original finish.
- D. Clean all debris from enclosure interiors.
- E. Test all shunt trip and under voltage trip units.

3.3 LABELING

- A. Provide nameplates on all switch enclosures wherein new circuits are modified or installed. Indicate the following information:
 - 1. Equipment Switch Serves.
 - 2. Branch Circuit.
 - 3. Normal (Black with white letters)
 - 4. Voltage, phase, wire, short circuit current rating
 - 5. Date installed

3.4 CLEARANCE AND WORKSPACE

- A. Maintain workspace and clearances as required by the NEC for the voltage encountered. No pipes or ducts shall pass above the outline of the switch enclosure. It shall be the responsibility of this Contractor to make sure that other trades do not encroach on this space.

END OF SECTION 262816

SECTION 264300 – SURGE PROTECTIVE DEVICES

PART 1 - GENERAL

1.1 SUBMITTALS

- A. Refer to section 260510.

1.2 QUALITY ASSURANCE

- A. Reference Standard: Comply with the latest edition of the applicable provisions and recommendations of the following, except as otherwise stated in this document:
 1. UL 1449 3rd Edition 2009 Revision
 2. UL 1283.
 3. ANSI/IEEE C62.41, Recommended Practice for Surge Voltages in Low-Voltage AC Power Circuits.
 4. ANSI/IEEE C62.45, Guide for Surge Testing for equipment connected to Low-Voltage AC Power Circuits.
 5. IEEE 1100 Emerald Book.
 6. National Fire Protective Association (NFPA 70: National Electrical Code).

1.3 WARRANTY

- A. Provide a 5 year product warranty

PART 2 - PRODUCTS

2.1 BASIS OF DESIGN

- A. Acceptable manufacturers, contingent upon compliance with the contract documents, are as listed below. Bidders shall carefully review the requirements listed in the technical specifications and only submit products that are equal or better. Equal products by other manufacturers are acceptable providing substitutions are submitted in accordance with requirements listed in the front end specifications and approved by the A/E. Bidders shall carefully review the front end documents and submit all information required to allow the A/E the ability to make a fully informed decision.
 1. Current Technology – or equal
 2. Acceptable Manufacturers: Current Technology, Liebert, & Schneider.

2.2 ELECTRICAL REQUIREMENTS

- A. Declared Maximum Continuous Operating Voltage (MCOV) shall be greater than 115 percent of the nominal system operating voltage and in compliance with test and evaluation procedures outlined in the nominal discharge surge current test of UL1449 3rd Edition, section 37.7. MCOV values claimed based on the component's value or on the 30-minute 115% operational voltage test, section 38 in UL1449 will not be accepted.
- B. Unit shall have not more than 10% deterioration or degradation of the UL1449 3rd Edition Voltage Protective Rating (VPR) due to repeated surges. Unit shall have a monitoring option available to be able to test and determine the percentage of protective available at all times.
- C. Protection Modes: SVR(6kV, 500A) and UL1449 3rd Edition VPR(6kV, 3kA) for grounded WYE/delta and High Leg Delta circuits with voltages of (480Y/277), (208Y/120), (600Y/347) 3-Phase/4 wire and (120/240) Split phase/3 wire circuits shall be as follows and comply with

test procedures outlined in UL1449 3rd Edition section 37.6.

| System Voltage | Mode | MCOV | B3 Ringwave | C3 Comb. Wave | UL 1449 Second Edition SVR Rating | UL 1449 Third Edition VPR Rating |
|----------------|------|------|-------------|---------------|-----------------------------------|----------------------------------|
| 120/240 | L-N | 150 | 325/375 | 650/775 | 400/400 | 700/700 |
| 120/208 | L-G | 150 | 400/450 | 650/825 | 500/500 | 700/700 |
| | N-G | 150 | 350/350 | 500/500 | 500/500 | 900/900 |
| | L-L | 300 | 400/500 | 950/1250 | 700/700 | 900/900 |
| 277/480 | L-N | 320 | 550/600 | 1125/1225 | 900/900 | 1000/1000 |
| | L-G | 320 | 850/875 | 1075/1225 | 1000/1000 | 1200/1200 |
| | N-G | 320 | 700/700 | 900/900 | 800/800 | 1200/1200 |
| | L-L | 550 | 650/750 | 1950/2200 | 1500/1500 | 1800/1800 |

- D. Electrical Noise Filter- each unit shall include a high performance EMI/RFI noise rejection filter. Noise attenuation for electric noise shall be as follows using the MIL-STD-220B insertion loss test method.
1. 100 kHz at 44 db or better.
 2. All other frequencies should be 32 db or better.
- E. Each fuse shall be individually sealed in a manner that eliminates the potential for cross arcing.
- F. Each unit shall provide the following features:
1. Phase Indicator lights, Form C dry contacts, surge counter and audible alarm.
 2. Field testable while installed.
 3. Measuring capability to indicate the percent protective available in SPD.

PART 3 - EXECUTION

3.1 INSTALLATION

- A. SPD shall be installed per manufacturer's installation instructions with lead lengths as short (less than 24") and straight as possible. Gently twist conductors together.
- B. Provide a circuit breaker in the electrical panel in accordance with manufacturer's installation instructions.
- C. The UL 1449 Voltage Protective Rating (VPR) shall be permanently affixed to the SPD unit.
- D. The UL 1449 Nominal Discharge Surge Current Rating shall be a minimum of 20kA.
- E. Surge Current Rating of device shall be as noted on drawings.
- F. The SCCR rating of the SPD shall be 200kAIC without requiring an upstream protective device for safe operation.
- G. The unit shall be listed as a Type 1 SPD, suitable for use in both Type 1 and Type 2 locations per UL1449 3rd Edition.

END OF SECTION 264300

SECTION 265100 – LIGHTING

PART 1 - GENERAL

1.1 SUMMARY

- A. This section includes the requirements for the following:
 - 1. Interior luminaires and accessories.
 - 2. Emergency lighting units.
 - 3. Exit signs.
 - 4. Luminaire accessories.

1.2 SUBMITTALS

- A. Refer to section 260510.

1.3 QUALITY ASSURANCE

- A. Conform to requirements of NFPA 70 and NFPA 101.
- B. Manufacturer Qualifications: Company specializing in manufacturing the products specified in this section with minimum three years documented experience.
- C. Products: Listed and classified by Underwriters Laboratories Inc. as suitable for the purpose specified and indicated.

1.4 REFERENCE STANDARDS

- A. ANSI C78.379 - American National Standard for Electric Lamps -- Reflector Lamps -- Classification of Beam Patterns; current edition.
- B. ANSI C78.377 – American National Standard for Electric Lamps – Specifications for the Chromaticity of Solid State Lighting Products.
- C. IESNA LM-63 - ANSI Approved Standard File Format for Electronic Transfer of Photometric Data and Related Information; current edition.
- D. IESNA LM-79-08 – Approved Method: Electrical and Photometric Measurements of Solid-State Lighting Products.
- E. IESNA LM-80-08 – Approved Method: Measuring Lumen Maintenance of LED Light Sources.
- F. NECA/IESNA 500 - Standard for Installing Indoor Commercial Lighting Systems; National Electrical Contractors Association; current edition.
- G. NEMA WD 6 - Wiring Devices - Dimensional Requirements; National Electrical Manufacturers Association; current edition.
- H. NFPA 70 - National Electrical Code; National Fire Protection Association, current edition.

PART 2 - PRODUCTS

2.1 MANUFACTURERS

- A. Basis of design and acceptable manufactures are as scheduled on drawings. Equal products by other manufacturers are acceptable providing substitutions are submitted in accordance with requirements listed elsewhere in the Bid Documents and approved by the A/E.
- B. Prior Approved Equal Manufacturer(s) are listed in lighting fixture schedule on drawings.
- C. LM-79 reports must be submitted with all proposed LED substitutions from Basis of Design, regardless of whether manufacturer is listed as an approved equal.

2.2 LUMINAIRES

- A. Furnish products as indicated in Schedule on plans.

2.3 EMERGENCY LED DRIVERS

- A. Regardless of catalogue number shown in fixture schedule, all fixtures indicated to be emergency type shall be provided with emergency type driver battery packs conforming to the following:
 - 1. Fixture Using Integral Emergency Driver/Battery Pack: Provide emergency driver installed within the fixture. The charging light and test switch shall be accessible/visible from below. Driver/Battery must be capable of operating fixture at 75% of fixture lumens for a minimum of 90 minutes. Drivers/batteries shall have full 5-year warranty.
 - 2. Fixture Using Remote Emergency Driver/Battery Pack: Provide Iota or Bodine emergency driver/battery pack installed remotely above accessible ceiling. Driver/Battery must be capable of operating fixture at 75% of fixture lumens for a minimum of 90 minutes. Drivers/batteries shall have full 5-year warranty.
- B. Integral emergency drivers/batteries shall be factory installed whenever possible.
- C. Drivers/batteries installed in fixtures located outdoors or unheated spaces shall be suitable for the ambient temperatures encountered or remotely located in a nearby accessible space.

PART 3 - EXECUTION

3.1 INSTALLATION

- A. Install fixtures securely, in a neat and workmanlike manner, as specified in NECA 500 (commercial lighting).
- B. Install suspended luminaires and exit signs using pendants supported from swivel hangers. Provide pendant length required to suspend luminaire at indicated height.
- C. Locate recessed ceiling luminaires as indicated on reflected ceiling plan.
- D. Install surface mounted luminaires and exit signs plumb and adjust to align with building lines and with each other. Secure to prevent movement.
- E. Install recessed luminaires to permit removal from below.
- F. Install recessed luminaires using accessories and firestopping materials to meet regulatory requirements for fire rating.

- G. Install clips to secure recessed grid-supported luminaires in place.
- H. Install wall mounted luminaires, emergency lighting units, and exit signs at height as indicated on Drawings.
- I. Install accessories furnished with each luminaire.
- J. Make wiring connections to branch circuit using building wire with insulation suitable for temperature conditions within luminaire.
- K. Bond products and metal accessories to branch circuit equipment grounding conductor.
- L. Install specified lamps in each emergency lighting unit, exit sign, and luminaire.

3.2 FIELD QUALITY CONTROL

- A. Perform field inspection in accordance with Section 01 40 00.
- B. Operate each luminaire after installation and connection. Inspect for proper connection and operation.

3.3 ADJUSTING

- A. Aim and adjust luminaires as indicated.
- B. Position exit sign directional arrows as indicated.

3.4 CLEANING

- A. Clean electrical parts to remove conductive and deleterious materials.
- B. Remove dirt and debris from enclosures.
- C. Clean photometric control surfaces as recommended by manufacturer.
- D. Clean finishes and touch up damage.

3.5 CLOSEOUT ACTIVITIES

- A. Demonstrate luminaire operation for minimum of two hours.

3.6 PROTECTION

- A. Replace/Repair luminaires that have failed at Substantial Completion.

END OF SECTION 265100

SECTION 270500 – COMMON WORK RESULTS FOR COMMUNICATIONS

PART 1 - GENERAL

1.1 RELATED SECTIONS

- A. All division 27 work shall, in addition to all division 1 specification sections, comply with all of the requirements in the following specification sections:

- 260500 Common Work Results for Electrical
- 260501 Electrical Demolition
- 260510 Electrical Submittals
- 260511 Electrical Work Closeout
- 260512 Electrical Coordination
- 260519 Low-Voltage Electrical Conductors and Cables
- 260526 Grounding and Bonding for Electrical Systems
- 260529 Hangers and Supports for Electrical Systems
- 260533 Raceway and Boxes for Electrical Systems
- 260536 Cable Trays for Electrical Systems
- 260548 Vibration and Seismic Controls for Electrical Systems
- 260553 Identification for Electrical Systems
- 262726 Wiring Devices

END OF SECTION 270500

SECTION 271101 – COMMUNICATION EQUIPMENT RACKS

PART 1 - GENERAL

1.1 SUBMITTALS

- A. Refer to section 260510

PART 2 - PRODUCTS

2.1 PERFORMANCE REQUIREMENTS

- A. Seismic Performance: Equipment frames shall withstand the effects of earthquake motions determined according to ASCE/SEI 7
 - 1. The term "withstand" means "the unit will remain in place without separation of any parts from the device when subjected to the seismic forces specified and the unit will be fully operational after the seismic event."

2.2 EQUIPMENT FRAMES

- A. Basis-of-Design Product: Subject to compliance with requirements, provide Server Room racks fully enclosed Switch Cabinets 32"x40" 45 RU with vertical cable management. Provide with perforated sides and perforated front and back doors. Communication rooms shall have 4 post racks with vertical cable management.
- B. Floor-Mounted Racks:
 - 1. Perforated removable and lockable side panels (Server Room Only).
 - 2. Perforated hinged and lockable front and rear doors. (Server Room Only).
 - 3. All cabinets keyed alike (Server Room Only).
 - 4. Adjustable feet for leveling.
 - 5. Cable access provisions in the roof and base.
 - 6. Grounding bus bar.
 - 7. Baked-polyester powder coat finish.
 - 8. Secure the Racks to the floor structure per the seismic requirements of an $I_p=1.0$.
- C. Comply with J-STD-607-A.

2.3 PDU'S

- A. Power Strips: Comply with UL 1363. See general notes on the construction documents.
 - 1. Listed and labeled as defined in NFPA 70, by a qualified testing agency, and marked for intended location and application.

2.4 LABELING

- A. Comply with TIA/EIA-606-A and UL 969 for a system of labeling materials, including label stocks, laminating adhesives, and inks used by label printers.
- B. Label each rack front and back. Coordinate labeling standards through shop drawing process.

PART 3 - EXECUTION

3.1 INSTALLATION

- A. Comply with NECA 1.
- B. Comply with BICSI TDMM for layout and installation of communications equipment rooms.

3.2 GROUNDING

- A. Install grounding according to BICSI TDMM, "Grounding, Bonding, and Electrical Protection" Chapter. Refer to Section 260526 Grounding and Bonding for Electrical Systems.
- B. Comply with J-STD-607-A.
- C. Bond metallic equipment to the grounding bus bar, using not smaller than No. 6 AWG equipment grounding conductor.
 - 1. Bond the shield of shielded cable to the grounding bus bar in communications rooms and spaces.

3.3 IDENTIFICATION

- A. Labels shall be preprinted or computer-printed type. Label each equipment rack and PDU,

END OF SECTION 271100

SECTION 271300 - COMMUNICATIONS BACKBONE CABLING

PART 1 - GENERAL

1.1 DEFINITIONS

- A. BICSI: Building Industry Consulting Service International.
- B. EMI: Electromagnetic interference.
- C. IDC: Insulation displacement connector.
- D. LAN: Local area network.
- E. RCDD: Registered Communications Distribution Designer.
- F. UTP: Unshielded twisted pair.

1.2 BACKBONE CABLING DESCRIPTION

- A. Backbone cabling system shall provide interconnections between communications equipment rooms, main terminal space, and entrance facilities in the telecommunications cabling system structure. Cabling system consists of backbone cables, and mechanical terminations.

1.3 PERFORMANCE REQUIREMENTS

- A. General Performance: Backbone cabling system shall comply with transmission standards in TIA/EIA-568-B.1, when tested according to test procedures of this standard.

1.4 ACTION SUBMITTALS

- A. Product Data: For each type of product indicated.
 - 1. For cable, include the following installation data for each type used:
 - a. Nominal OD.
 - b. Minimum bending radius.
 - c. Maximum pulling tension.
 - 2. Fire Stop products
- B. Shop Drawings:
 - 1. System Labeling Schedules: Electronic copy of labeling schedules.
 - 2. Cabling administration drawings and printouts.
 - 3. Wiring diagrams to show typical wiring schematics including the following:
 - a. Patch panels.
 - 4. Patch panels. Detail mounting assemblies, and show elevations and physical relationship between the installed components.

1.5 INFORMATIONAL SUBMITTALS

- A. Field quality-control reports.

- B. Maintenance Data: For splices and connectors to include in maintenance manuals.
- C. UL training documentation for all staff for “Achieving Code Compliance Using UL Fire Resistance Designs”

1.6 CLOSEOUT SUBMITTALS

- A. Software and Firmware Operational Documentation:
 - 1. Software operating and upgrade manuals.
 - 2. Program Software Backup: On magnetic media or compact disk, complete with data files.
 - 3. Device address list.
 - 4. Printout of software application and graphic screens.

1.7 QUALITY ASSURANCE

- A. Installer Qualifications: Cabling Installer must have personnel certified by BICSI on staff.
 - 1. Layout Responsibility: Preparation of Shop Drawings Cabling Administration Drawings, and field testing program development by an RCDD.
 - 2. Installation Supervision: Installation shall be under the direct supervision of Level 2 Installer
 - 3. Testing Supervisor: Currently certified by BICSI as an RCDD to supervise on-site testing.
- B. Testing Agency Qualifications: An NRTL.
 - 1. Testing Agency's Field Supervisor: Currently certified by BICSI as an RCDD to supervise on-site testing.
- C. Surface-Burning Characteristics: As determined by testing identical products according to ASTM E 84 by a qualified testing agency. Identify products with appropriate markings of applicable testing agency.
 - 1. Flame-Spread Index: 25 or less.
 - 2. Smoke-Developed Index: 50 or less.
- D. Electrical Components, Devices, and Accessories: Listed and labeled as defined in NFPA 70, by a qualified testing agency, and marked for intended location and application.
- E. Telecommunications Pathways and Spaces: Comply with TIA/EIA-569-A.
- F. Grounding: Comply with ANSI-J-STD-607-A.

1.8 DELIVERY, STORAGE, AND HANDLING

- A. Test cables upon receipt at Project site.
 - 1. Test optical fiber cable to determine the continuity of the strand end to end. Use optical fiber flashlight or optical loss test set
 - 2. Test optical fiber cable while on reels. Use an optical time domain reflectometer to verify the cable length and locate cable defects, splices, and connector, including the loss value of each. Retain test data and include the record in maintenance data.
 - 3. Test each pair of UTP cable for open and short circuits.

PART 2 - PRODUCTS

2.1 PATHWAYS

- A. General Requirements: Comply with TIA/EIA-569-A.
- B. Cable Support: NRTL labeled for support of Category 6 cabling, designed to prevent degradation of cable performance and pinch points that could damage cable. All supports shall be plenum rated.
 - 1. Support brackets with cable tie slots for fastening cable ties to brackets.
 - 2. Lacing bars, spools, J-hooks, and D-rings.
 - 3. Straps and other devices.

2.2 UTP CABLE

- A. Acceptable manufacturers, contingent upon compliance with the contract documents, are as listed below. Bidders shall carefully review the requirements listed in the technical specifications and only submit products that are equal or better. Equal products by other manufacturers are acceptable providing substitutions are submitted in accordance with requirements listed in the "Instructions to Bidders" (AIA A701) and approved by the A/E. Bidders shall carefully review the front end documents (AIA A701) and submit all information required to allow the A/E the ability to make a fully informed decision.
 - 1. Belden CDT Inc.; Electronics Division.
 - 2. Berk-Tek; a Nexans company.
 - 3. CommScope, Inc.
 - 4. Mohawk; a division of Belden CDT.
 - 5. Superior Essex Inc.
 - 6. SYSTIMAX Solutions; a CommScope Inc. brand.
 - 7. Panduit
- B. Description: 100-ohm, UTP, formed into 25-pair binder groups covered with a gray thermoplastic jacket.
 - 1. Comply with ICEA S-90-661 for mechanical properties.
 - 2. Comply with TIA/EIA-568-B.1 for performance specifications.
 - 3. Comply with TIA/EIA-568-B.2, Category 5e
 - 4. Listed and labeled by an NRTL acceptable to authorities having jurisdiction as complying with UL 444 and NFPA 70 for the following types:
 - a. Communications, Riser Rated: Type CMR complying with UL 1666 and NFPA 262. Cable shall be plenum rated.

2.3 UTP CABLE HARDWARE

- A. Hardware: Comply with TIA/EIA-568-B.2, IDC type, with modules designed for punch-down caps or tools. Cables shall be terminated with connecting hardware of same category or higher.
- B. Connecting Blocks: 66-style IDC for Category 5e. Provide blocks for the number of cables terminated on the block, plus 25 percent spare. Integral with connector bodies, including plugs and jacks where indicated.

2.4 OPTICAL FIBER CABLE

- A. Acceptable manufacturers, contingent upon compliance with the contract documents, are as listed below. Bidders shall carefully review the requirements listed in the technical specifications and only submit products that are equal or better. Equal products by other manufacturers are acceptable providing substitutions are submitted in accordance with requirements listed in the “Instructions to Bidders” and “Supplemental Instructions to Bidders” (AIA A701) and approved by the A/E. Bidders shall carefully review the front end documents (AIA A701) and submit all information required to allow the A/E the ability to make a fully informed decision.
1. Corning Cable Systems.
- B. Description: Multimode, 62.5/125-micrometer, or Single mode tight buffer, optical fiber cable.
1. Comply with ICEA S-83-596 for mechanical properties.
 2. Comply with TIA/EIA-568-B.3 for performance specifications.
 3. Listed and labeled by an NRTL acceptable to authorities having jurisdiction as complying with UL 444, UL 1651, and NFPA 70 for the following types:
 - a. Plenum Rated, Nonconductive: Type OFNP, complying with NFPA 262.
 4. Conductive cable shall be aluminum armored type. Provide armored protection for all fiber cables that are installed outside of the IDF closet. (fiber in IDF closets can be non-armored)
- C. Jacket:
1. Jacket Color: Orange for multimode, yellow for single mode.
 2. Cable cordage jacket, fiber, unit, and group color shall be according to TIA/EIA-598-B.
 3. Imprinted with fiber count, fiber type, and aggregate length at regular intervals not to exceed 40 inches.

2.5 OPTICAL FIBER CABLE HARDWARE

- A. Acceptable manufacturers, contingent upon compliance with the contract documents, are as listed below. Bidders shall carefully review the requirements listed in the technical specifications and only submit products that are equal or better. Equal products by other manufacturers are acceptable providing substitutions are submitted in accordance with requirements listed in the “Instructions to Bidders” and “Supplemental Instructions to Bidders” (AIA A701) and approved by the A/E. Bidders shall carefully review the front end documents (AIA A701) and submit all information required to allow the A/E the ability to make a fully informed decision.
1. Panduit.
 2. Corning Cable Systems.
- B. Patch Panels: Modular panels housing multiple-numbered, duplex cable connectors.
1. Number of Connectors per Field: One for each fiber of cable or cables assigned to field, plus 25% spares.
- C. Cable Connecting Hardware:
1. Comply with Optical Fiber Connector Interchangeability Standards (FOCIS) specifications of TIA/EIA-604-2, TIA/EIA-604-3-A, and TIA/EIA-604-12. Comply with TIA/EIA-568-B.3.

2. Quick-connect, simplex and duplex, Type LC connectors. Insertion loss not more than 0.5 dB. Coordinate connector type with Engineer and Architect prior to ordering.

2.6 GROUNDING

- A. Comply with ANSI-J-STD-607-A.

2.7 IDENTIFICATION PRODUCTS

- A. Comply with TIA/EIA-606-A and UL 969 for a system of labeling materials, including label stocks, laminating adhesives, and inks used by label printers.

2.8 SOURCE QUALITY CONTROL

- A. Factory test cables on reels according to TIA/EIA-568-B.1.
- B. Factory test UTP cables according to TIA/EIA-568-B.2.
- C. Factory test
- D. Optical fiber cables according to TIA/EIA-526-14-A and TIA/EIA-568-B.3.
- E. Cable will be considered defective if it does not pass tests and inspections.
- F. Prepare test and inspection reports.

PART 3 - EXECUTION

3.1 WIRING METHODS

- A. Wiring Method: Install cables in raceways and cable trays.

3.2 INSTALLATION OF CABLES

- A. Comply with NECA 1.
- B. General Requirements for Cabling:
 1. Comply with TIA/EIA-568-B.1.
 2. Comply with BICSI ITSIM, Ch. 6, "Cable Termination Practices."
 3. Terminate all conductors; no cable shall contain unterminated elements. Make terminations only at indicated outlets, terminals, cross-connects, and patch panels.
 4. Cables may not be spliced. Secure and support cables at intervals not exceeding 30 inches (760 mm) and not more than 6 inches (150 mm) from cabinets, boxes, fittings, outlets, racks, frames, and terminals.
 5. Install lacing bars to restrain cables, to prevent straining connections, and to prevent bending cables to smaller radii than minimums recommended by manufacturer.
 6. Bundle, lace, and train conductors to terminal points without exceeding manufacturer's limitations on bending radii, but not less than radii specified in BICSI ITSIM, "Cabling Termination Practices" Chapter. Use lacing bars and distribution spools.

7. Do not install bruised, kinked, scored, deformed, or abraded cable. Do not splice cable between termination, tap, or junction points. Remove and discard cable if damaged during installation and replace it with new cable.
 8. In the communications equipment room, install a 10 foot (3m) long service loop on each end of cable.
 9. Pulling Cable: Comply with BICSI ITSIM, Ch. 4, "Pulling Cable." Monitor cable pull tensions.
- C. UTP Cable Installation:
1. Comply with TIA/EIA-568-B.2.
- D. Optical Fiber Cable Installation:
1. Comply with TIA/EIA-568-B.3.
 2. Cable may be terminated on connecting hardware that is rack or cabinet mounted.
- E. Open-Cable Installation:
1. Install cabling with horizontal and vertical cable guides in telecommunications spaces with terminating hardware and interconnection equipment.
 2. Suspend cable not in a wireway or pathway, by cable supports not more than 60 inches apart.
 3. Cable shall not be run through structural members or in contact with pipes, ducts, or other potentially damaging items.
- F. Group connecting hardware for cables into separate logical fields.
- 3.3 FIRESTOPPING
- A. Comply with TIA/EIA-569-A, Annex A, "Firestopping."
 - B. Comply with BICSI TDMM, "Firestopping Systems" Article.
- 3.4 GROUNDING
- A. Install grounding according to BICSI TDMM, "Grounding, Bonding, and Electrical Protection" Chapter.
 - B. Comply with ANSI-J-STD-607-A.
 - C. Bond metallic equipment to the grounding bus bar, using not smaller than No. 6 AWG equipment grounding conductor.
- 3.5 IDENTIFICATION
- A. Identify system components, wiring, and cabling complying with TIA/EIA-606-A
 1. Color-code cross-connect fields and apply colors to voice and data service backboards, connections, covers, and labels.
 - B. Cable Schedule: Install in a prominent location in each equipment room and wiring closet. List incoming and outgoing cables and their designations, origins, and destinations. Protect with

rigid frame and clear plastic cover. Furnish an electronic copy of final comprehensive schedules for Project.

- C. Cabling Administration Drawings: Show building floor plans with cabling administration-point labeling. Identify labeling convention and show labels for telecommunications closets, backbone pathways and cables, terminal hardware and positions, horizontal cables, work areas and workstation terminal positions, grounding buses and pathways, and equipment grounding conductors. Install a laminated cable administration drawing showing the building fiber risers in the MDF and the building copper risers in the Rohm room.
- D. Cable and Wire Identification:
 - 1. Exposed Cables and Cables in Cable Trays and Wire Troughs: Label each cable at intervals not exceeding 15 feet (4.5 m).
 - 2. Label each terminal strip and screw terminal in each cabinet, rack, or panel.
 - a. Individually number wiring conductors connected to terminal strips and identify each cable or wiring group being extended from a panel or cabinet to a building-mounted device with name and number of particular device as shown.
 - b. Label each unit and field within distribution racks and frames.
 - 3. Identification within Connector Fields in Equipment Rooms and Wiring Closets: Label each connector and each discrete unit of cable-terminating and connecting hardware. Where similar jacks and plugs are used for both voice and data communication cabling, use a different color for jacks and plugs of each service.
- E. Labels shall be preprinted or computer-printed type with printing area and font color that contrasts with cable jacket color but still complies with requirements in TIA/EIA 606-A, for the following: (all labels and material shall be plenum rated)
 - 1. Cables use flexible vinyl or polyester that flexes as cables are bent.

3.6 FIELD QUALITY CONTROL

- A. Perform tests and inspections.
- B. Tests and Inspections:
 - 1. Visually inspect UTP and optical fiber jacket materials for NRTL certification markings. Inspect cabling terminations in communications equipment rooms for compliance with color-coding for pin assignments, and inspect cabling connections for compliance with TIA/EIA-568-B.1.
 - 2. Visually inspect cable placement, cable termination, grounding and bonding, equipment and patch cords, and labeling of all components.
 - 3. Test UTP copper cabling for DC loop resistance, shorts, opens, intermittent faults, and polarity between conductors. Test operation of shorting bars in connection blocks. Test cables after termination but not cross-connection.
 - a. Test instruments shall meet or exceed applicable requirements in TIA/EIA-568-B.2. Perform tests with a tester that complies with performance requirements in "Test Instruments (Normative)" Annex, complying with measurement accuracy specified in "Measurement Accuracy (Informative)" Annex. Use only test cords and adapters that are qualified by test equipment manufacturer for channel or link test configuration.
 - 4. Optical Fiber Cable Tests:

- a. Test instruments shall meet or exceed applicable requirements in TIA/EIA-568-B.1. Use only test cords and adapters that are qualified by test equipment manufacturer for channel or link test configuration.
 - b. Perform Link End-to-End Attenuation Tests
- C. Data for each measurement shall be documented. Data for submittals shall be printed in a summary report that is formatted similar to Table 10.1 in BICSI TDMM, or transferred from the instrument to the computer, saved as text files, and printed and submitted.
- D. Remove and replace cabling where test results indicate that they do not comply with specified requirements.
- E. End-to-end cabling will be considered defective if it does not pass tests and inspections.
- F. Prepare test and inspection reports.

END OF SECTION 271300

SECTION 280500 – COMMON WORK RESULTS FOR SAFETY AND SECURITY

PART 1 - GENERAL

1.1 RELATED SECTIONS

- A. All division 28 work shall, in addition to all division 1 specification sections, comply with all of the requirements in the following specification sections:

260500 Common Work Results for Electrical
260501 Electrical Demolition
260510 Electrical Submittals
260511 Electrical Work Closeout
260512 Electrical Coordination
260519 Low-Voltage Electrical Conductors and Cables
260526 Grounding and Bonding for Electrical Systems
260529 Hangers and Supports for Electrical Systems
260533 Raceway and Boxes for Electrical Systems
260548 Vibration and Seismic Controls for Electrical Systems
260553 Identification for Electrical Systems
262726 Wiring Devices

END OF SECTION 280500

SECTION 28 10 00
ACCESS CONTROL REQUIREMENTS**PART 1 GENERAL****1.01 SECTION INCLUDES**

- A. Access Control Specifications.
- B. **The General Contractor shall contract with Carolina Innovative Research, Ltd. Co. to provide all materials and installation for the access control system.**

1.02 RELATED REQUIREMENTS

- A. Section 08 71 00 – Door Hardware.

1.03 SUBMITTALS

- A. Product Data Submittals: Submit manufacturer's standard published data. Mark each copy to identify applicable products, models, options, and other data. Supplement manufacturers' standard data to provide information specific to this Project.
- B. Shop Drawing Submittals: Prepared specifically for this Project; indicate utility and electrical characteristics, utility connection requirements, and location of utility outlets for service for functional equipment and appliances.

PART 2 PRODUCTS**201 PRODUCTS**

- A. Provide products as specified in Access Control Specifications –Submitted by the Infrastructure Services Team of Carolina Innovative Research, Ltd. Co. attached.

PART 3 EXECUTION**301 INSTALLATION**

- A. The complete installation shall be done in a neat, workmanlike manner in accordance with Division 26 of these documents and manufacturer's recommendations.
- B. Coordinate with the Division 08 contractor regarding the doorframes and hardware equipment which is associated with the Access Control System. Verify rough-in and installation requirements for all door frame mounted and/or door mounted control and monitoring equipment.
- C. Prior to start of construction, confirm installation requirements with the Agency. The coordination shall include, but not be limited to, hardware, cabling and wiring requirements including types, sizes, color-coding schemes, labeling, wire way requirements, termination responsibilities, and cable identification requirements.
- D. Coordinate with Division 26 installer to confirm required cabling pathways, device rough-ins, and line-voltage power requirements.
- E. Receive, store and install Access Control System equipment and cabling as specified. Comply with the manufacturer's instructions and recommendations for installation of all products. Provide all system wiring between all components in accordance with manufacturer's guidelines. Each cable for each device shall be home run. No splices are allowed unless otherwise noted

END OF SECTION

Access Control Specifications – Harrelson IT Upgrades

Colleton County Government

Submitted by the
Infrastructure Services Team of
Carolina Innovative Research, Ltd. Co.

Prepared By:

Carolina innovative Research, Ltd. Co.
301 Greystone Blvd. Suite 125
Columbia, SC 29210

Chavous P. Camp
(803) 470-2000

ccamp@carolinainnovative.com

Prepared For:

Colleton County
Technology Department
31 Klein St.
Harrelson Bldg
Walterboro, SC 29488

Eric Avant



Situation

There are 10 doors that, as part of Colleton County Government’s upgrade plans to the lower floor Harrelson bldg. IT service are that require access control. This document lays out options and specifications for the access control on those doors as well as costs for securing each.

Wiring

As usual, all readers require CAT-6-rated cabling from a POE-capable network switch to the reader. “Remote unlock” PBX Web relays require an additional POE-capable CAT-6 rated network cable. See note (5) for locations. Previously, Colleton county has provided all network wiring. This action plan assumes Colleton County will continue this practice. **NOTE: CABLES MUST BE INSTALLED PRIOR TO INSTALLATION AT EACH DOOR AND MUST BE FULLY TESTED. HOURLY CHARGES WILL APPLY IF ADDITIONAL WORK IS REQUIRED DUE TO A LACK OF SITE PREPARATION.**

Door Function Warning

For access control to function properly, *all doors must be in working condition, aligned with their strikes properly, and with closers that function properly. Additionally, each cylindrical lock should use a “storeroom” lockset, to ensure all doors remain locked and can’t be left in an unlocked state without the access control system’s assistance.*

THESE RECOMMENDATIONS ASSUME THAT ALL DOORS ARE IN NEW WORKING CONDITION. SEE REQUIRED SITE CONDITIONS BELOW.

Budgetary Pricing

Doors

| Description | RU | K | Strike/EL | Price | Note |
|-----------------------------------|--------------|---|---------------------------|------------------------|--------------------|
| IT Hallway - Interior (108) | Y | Y | Trine 4100-32D | \$ 3,886.42 | (1) (3) (4) |
| IT Hallway - Stairs (112) | | Y | Trine 4850POE-32D | \$ 3,565.03 | (2) (4) |
| Mechanical Room Door (121) | | Y | Trine 4100-32D | \$ 3,880.03 | (1) (4) (5) |
| Office Door (120) | | Y | Trine 4100-32D | \$ 3,460.03 | (1) (4) |
| Open Office Door 1 (122) | | Y | Trine 4100-32D | \$ 3,460.03 | (1) (4) |
| Open Office Door 2 (123) | | Y | Trine 4100-32D | \$ 3,565.03 | (1) (4) |
| GIS Public Area (109A) | Y | | Trine 4100-32D | \$ 3,571.42 | (1) (3) |
| GIS Office Area (109B) | | | Trine 4100-32D | \$ 3,250.03 | (1) |
| Tech/GIS Office (109) | | | Trine 4100-32D | \$ 3,355.03 | (1) |
| IT Data Center (110) | | Y | Trine 4100-32D | \$ 3,565.03 | (1) |

Legend: RU = Remote Unlock K = Includes Keypad Reader

Notes

- (1) If not previously installed, contractor/county to install county-standard cylindrical lockset with STOREROOM cylinder & trim. CI Team will cut doorframe to install strike
- (2) If not previously installed, contractor/county to install county-standard RIM-style panic bar with keyed lockset. Keyed lockset must be configured for STOREROOM operation.
- (3) PBX "Web" remote unlock module will be provided. Additional CAT-6 network drop needed to this location. Change 4x4 surface mounted box to 6x6 for this location.
- (4) Keypad reader will be provided by CI
- (5) Armored Power Transfer Loop to be installed by CI to provide power for latch installed in double door

Other Specifications

Ethernet Specifications

- One CAT-6 network drop must be provided to the below-listed junction box for each door, except where noted (see note 5 and note 1). Sufficient length (25') service loop must be provided to reach through conduit and to reader if necessary.
- Each network cable must be terminated into a Power-Over-Ethernet+ (POE+)-capable switch, rated for 802.3at (30W/port).

Locksets/Trim/Electrified Locks

- All locksets/trim should be ordered in "Storeroom" configuration
- Our locksmiths will install electric strikes themselves.
- This proposal assumes the strikes listed under Strike/EL will be provided AND INSTALLED BY the CI install team.

Conduit & Junction Boxes

All doors

- Except where noted (3), above door: 4x4 (2-gang) surface mount communication box mounted on wall. For those doors noted with (3), provide a 6x6 box.
- At Reader location, on “insecure” / “exterior” side of door: single-gang in-wall electrical box unless wall material is cinderblock. Then, please install single-gang surface-mount electrical box.
- Conduit with jetline or other pull string must be provided from above-door box to the reader in-wall electrical box.
- Conduit with jetline or other pull string must be provided from above-door box to the door strike
- EMT with jetline must be pulled to any boxes where there the wall material is cinderblock

Other Hardware

- All doors should have appropriate door closer hardware installed by the county or the contractor.

Scope

- Physical Installation will be performed by certified Isonas installers and licensed, certified locksmiths. Integration will be performed by Isonas-certified installers/integrators.
- Provide new access control strikes, reader/controller devices, PIR REX motion sensors, door open/close sensors and web-relay hardware where noted
- Install above hardware on fully-working doors, per notes above
- Provide basic door / closer adjustment as necessary.
- Integrate all doors with the existing PureAccess Cloud setup
- Work with CC Technology Department to establish door access rules and provide basic staff training as necessary
- Work with CC Technology Department to integrate web-based door relay releases into their video/IP phone product

Pricing

Total hardware: \$24,578.10

Integration/Installation: \$10,350

Subtotal: \$34,928.10

SC Sales Tax (8%): \$1,966.25

Total: \$36,864.35

Terms and Payment

Pricing/availability is valid for 60 days. Changes to hardware pricing may be required upon PO issuance if PO is issued after 60 days, due to changes in product availability/discontinuation of product by

manufacturers/etc. Such changes will be communicated to contractor prior to CI's acceptance of purchase order.

Payment terms:

50% will be invoiced and due upon CI's acceptance of purchase order. 50% will be invoiced upon completion and acceptance by contractor/client and due net-15.

Purchase orders containing wording contrary to these terms are not valid unless agreed upon in writing by CI.

SECTION 283101 – FIRE DETECTION AND ALARM

PART 1 - GENERAL

1.1 SUBMITTALS

- A. Refer to section 260510

1.2 QUALITY ASSURANCE

- A. Installer Qualifications: NICET Level III certified fire alarm technician.
 - 1. Authorized representative of control unit manufacturer; submit manufacturer's certification that installer is authorized; include name and title of manufacturer's representative making certification.

1.3 RELATED DOCUMENTS

- A. The system and all associated operations shall be in accordance with the following:
 - 1. Guidelines of the following Building Code: IBC
 - 2. NFPA 72, National Fire Alarm Code
 - 3. NFPA 70, National Electrical Code
 - 4. NFPA 101, Life Safety Code
 - 5. NFPA 90A, Standard for the Installation of Air Conditioning and Ventilating Systems
 - 6. Other applicable NFPA standards
 - 7. Local Jurisdictional Adopted Codes and Standards
 - 8. ADA Accessibility Guidelines

1.4 WARRANTY

- A. Provide installer's warranty that the installation is free from defects and will remain so for 1 year after date of Substantial Completion.

PART 2 - PRODUCTS

2.1 MANUFACTURERS

- A. Acceptable manufacturers, contingent upon compliance with the contract documents, are as listed below. Bidders shall carefully review the requirements listed in the technical specifications and only submit products that are equal or better. Equal products by other manufacturers are acceptable providing substitutions are submitted in accordance with requirements listed in the "Instructions to Bidders" (AIA A701) and approved by the A/E. Bidders shall carefully review the front end documents (AIA A701) and submit all information required to allow the A/E the ability to make a fully informed decision.
 - 1. Fire Alarm Control Units, Basis of Design: FIRE-LITE 5UD.

2.2 FIRE ALARM SYSTEM

- A. Fire Alarm System: Expand the existing automatic fire detection and alarm system:
 - 1. Provide all components necessary, regardless of whether shown in the contract

documents or not.

2. Comply with the following; where requirements conflict, order of precedence of requirements is as listed:
 - a. The Americans With Disabilities Act (ADA).
 - b. The requirements of the local authority having jurisdiction, (DHEC).
 - c. The contract documents (drawings and specifications).
 - d. NFPA 72; where the word "should" is used consider that provision mandatory; where conflicts between requirements require deviation from NFPA 72, identify deviations clearly on design documents.
3. Evacuation Alarm: Multiple smoke zones; allow for evacuation notification of any individual zone or combination of zones, in addition to general evacuation of entire premises.
4. Voice Notification: Provide emergency voice/alarm communications with multichannel capability; digital.
5. General Evacuation Zones: Each smoke zone is considered a general evacuation zone unless otherwise indicated, with alarm notification in all zones on the same floor, on the floor above, and the floor below.
6. Program notification zones and voice messages as directed by Owner.

B. Circuits:

1. Initiating Device Circuits (IDC): Class B
2. Signaling Line Circuits (SLC) Within Single Building: Class B
3. Notification Appliance Circuits (NAC): Class B

C. Power Sources:

1. Primary: Dedicated branch circuits of the facility power distribution system.
2. Secondary: Storage batteries.
3. Capacity: Sufficient to operate entire system for period specified by NFPA 72.

2.3 EXISTING COMPONENTS

- A. Existing Fire Alarm System: Remove existing system and devices to be demoed completely after new system is fully operational and tested.
- B. On-Premises Supervising Station: Include as part of this work all modifications necessary to existing supervising station to accommodate new fire alarm work.
- C. Clearly label components that are "Not In Service."
- D. Remove unused existing components and materials from site and dispose of properly.
- E. Provide a fire watch for the building if the existing system is brought off line for any reason. Notify the AHJ of all fire watch plans.
- F. Protect any fire alarm devices that are in service from dust during construction operations.

2.4 FIRE SAFETY SYSTEMS INTERFACES

- A. Provide connection to all flow and tamper switches installed by the fire suppression contractor whether shown on the construction documents or not.

2.5 COMPONENTS

- A. General:
 - 1. Provide flush mounted units where installed in finish areas; in unfinished areas, surface mounted unit are acceptable.
 - 2. Provide legible, permanent labels for each control device, using identification used in operation and maintenance data.
- B. Fire Alarm Control Units, Initiating Devices, and Notification Appliances: Addressable type; listed by Underwriters Laboratories as suitable for the purpose intended.
- C. Initiating Devices:
 - 1. Manual Pull Stations: match existing
 - 2. Smoke Detectors: photo electric type, match existing
 - 3. Heat Detectors: rate of rise type, match existing
 - 4. Duct Smoke Detectors: match existing, coordinate with mechanical equipment and duct work installation. Provide a remote indicator for all duct detectors that are not visible from floor level. Provide a relay to send the shutdown signal to each piece of HVAC equipment. Coordinate with HVAC contractor and provide all required hardware and programming.
 - 5. Addressable Interface Devices: provide as required
- D. Notification Appliances:
 - 1. Bells: Match existing.
 - 2. Horns: Match existing.
 - 3. Strobes: adjustable candela - Match existing.
- E. Surge Protection: In accordance with IEEE C62.41 B3 combination waveform and NFPA 70; except for optical fiber conductors.
- F. Locks and Keys: Deliver keys to owner.

PART 3 - EXECUTION

3.1 INSTALLATION

- A. Install in accordance with applicable codes, NFPA 72, NFPA 70, and the contract documents.
- B. Conceal all wiring, conduit, boxes, and supports where installed in finished areas.

3.2 CIRCUIT BREAKERS

- A. Circuit breakers serving fire alarm devices shall be provided with a red fire alarm circuit breaker lockout kit that permanently identifies circuit as "FIRE ALARM".

3.3 INSPECTION AND TESTING FOR COMPLETION

- A. Notify engineer 7 days prior to beginning completion inspections and tests.
- B. Notify authorities having jurisdiction and comply with their requirements for scheduling inspections and tests and for observation by their personnel.
- C. Provide the services of the installer's supervisor or person with equivalent qualifications to supervise inspection and testing, correction, and adjustments.
- D. Prepare for testing by ensuring that all work is complete and correct; perform preliminary tests as required.
- E. Provide all tools, software, and supplies required to accomplish inspection and testing.
- F. Perform inspection and testing in accordance with NFPA 72 and requirements of local authorities; document each inspection and test.
- G. Correct defective work, adjust for proper operation, and retest until entire system complies with contract documents.

3.4 DHEC

- A. Attend above ceiling and final DHEC inspections. Demonstrate function of fire alarm system at inspections.

3.5 CLOSEOUT

- A. Closeout Demonstration: Demonstrate proper operation of all functions to owner.
 - 1. Be prepared to conduct any of the required tests.
 - 2. Have at least one copy of operation and maintenance data, preliminary copy of project record drawings, input/output matrix, and operator instruction chart(s) available during demonstration.
 - 3. Have authorized technical representative of control unit manufacturer present during demonstration.
 - 4. Demonstration may be combined with inspection and testing required by authority having jurisdiction; notify authority having jurisdiction in time to schedule demonstration.
 - 5. Repeat demonstration until successful.
- B. Substantial Completion of the project cannot be achieved until inspection and testing is successful and:
 - 1. Approved operating and maintenance data has been delivered.
 - 2. All aspects of operation have been demonstrated to Engineer.
 - 3. Final acceptance of the fire alarm system has been given by authorities having jurisdiction.
 - 4. Specified pre-closeout instruction is complete.

- C. Perform post-occupancy instruction within 3 months after Substantial Completion.

END OF SECTION 283101

